



# Environmental and Social Impact Assessment for HEMA Hard Coal Mine Project

Final Draft ESIA Report

September 2015

**Hattat Enerji ve Maden Ticaret A.Ş. (HEMA)**



a company of



**ELC GROUP A COMPANY OF ROYAL HASKONINGDHV**

Rüzgarlıbahçe Mah. Çınar Sok. No:2 Address  
Energy Plaza Kat:6 84805 Kavacık-Istanbul-Turkey  
+90 (0)216 465 91 30 Telephone  
+90 (0)216 465 91 39 Fax  
info@elcgroup.com.tr E-mail  
www.elcgroup.com.tr Internet  
www.royalhaskoningdhv.com

Document Title Environmental and Social Impact Assessment  
for HEMA Hard Coal Mine Project  
Document short title ESIA for HEMA Hard Coal Mine Project  
Status Final Draft ESIA Report  
Date September 2015  
Project Name ESIA for HEMA Hard Coal Mine Project  
Project Number HA1144  
Client Hattat Enerji ve Maden Ticaret A.Ş.  
Reference

This report has been prepared by ELC Group Consulting and Engineering Inc. with all reasonable skill, care and diligence, and taking account of the Services and the Terms agreed between ELC Group Consulting and Engineering Inc. and the Client. This report is confidential to the client, and ELC Group Consulting and Engineering Inc. accepts no responsibility whatsoever to third parties to whom this report, or any part thereof, is made known, unless formally agreed by ELC Group Consulting and Engineering Inc. beforehand. Any such party relies upon the report at their own risk.

ELC Group Consulting and Engineering Inc. disclaims any responsibility to the Client and others in respect of any matters outside the agreed scope of the Services.

Checked and Approved by Project Prof. Dr. Cem Avcı  
Director



Date/Initials Checked and Approved September 2015

## TABLE OF CONTENTS

<b>TABLE OF CONTENTS</b> .....	<b>I</b>
<b>ANNEXES</b> .....	<b>IX</b>
<b>LIST OF TABLES</b> .....	<b>X</b>
<b>LIST OF FIGURES</b> .....	<b>XV</b>
<b>ABBREVIATIONS</b> .....	<b>XX</b>
<b>1.0 INTRODUCTION</b> .....	<b>1-1</b>
1.1 Background and Objective .....	1-1
1.2 Turkish Environmental Impact Assessment Requirements .....	1-2
1.3 ESIA Requirements .....	1-3
1.4 Key Steps in the ESIA process.....	1-3
1.4.1 Overview .....	1-3
1.4.2 Screening.....	1-3
1.4.3 Scoping.....	1-4
1.4.4 Baseline Data Collection .....	1-5
1.4.5 Assessment of Impacts .....	1-6
1.4.6 Identification of Mitigation Measures .....	1-9
1.4.7 Uncertainties.....	1-9
1.4.8 Environmental and Social Management Plan (ESMP) .....	1-9
1.4.9 Stakeholder Engagement.....	1-10
1.5 Outline of the ESIA Report .....	1-10
<b>2.0 PROJECT DESCRIPTION</b> .....	<b>2-1</b>
2.1 Project Overview .....	2-1
2.1.1 Project Background.....	2-1
2.1.2 Background of HEMA in Coal Mining.....	2-3
2.1.3 Need for the Project.....	2-4
2.2 Evaluation of Project Alternatives.....	2-5
2.2.1 Site Alternatives .....	2-5
2.2.2 Technology Alternatives .....	2-5
2.3 Coal Mining .....	2-6
2.3.1 Production Blocks and Reserve Characteristics .....	2-6
2.3.2 Shaft Locations.....	2-10
2.3.3 Project Planning .....	2-12
2.3.4 Major Aboveground Developments .....	2-13
2.3.5 Major Underground Developments.....	2-20
2.3.6 Galleries .....	2-25
2.3.7 Production.....	2-32
2.3.8 Ventilation.....	2-38
2.3.9 Other Underground Developments.....	2-40

2.3.10	Power Supply .....	2-43
2.3.11	Water Supply/Wastewater Generation .....	2-43
2.3.12	Waste Rock and Spoil Dumpsites.....	2-44
2.3.13	Labor Requirements.....	2-45
2.4	Coal Washing Plants.....	2-49
2.4.1	Coal Washing Plants Overview.....	2-49
2.4.2	Amasra-Mine Coal Washing Plant (ACWP) Process Details .....	2-49
2.4.3	Shallow Coals Washing Plant (SCWP) Process Details .....	2-51
2.4.4	Power Supply .....	2-52
2.4.5	Water Supply/Wastewater Generation .....	2-52
2.4.6	Labor Requirements.....	2-52
2.5	HEMA Port (Reclamation Area and Quay) .....	2-53
2.5.1	HEMA Port Overview .....	2-53
2.5.2	Other Ports in the Area .....	2-54
2.5.3	HEMA Port (Reclamation and Quay) Project Components and Design .....	2-55
2.5.4	Design Vessels and Navigation.....	2-63
2.5.5	Construction and Operation Timeline .....	2-63
2.5.6	Port Construction.....	2-65
2.5.7	Port Operation .....	2-65
2.5.8	Labor Requirements.....	2-67
2.6	Road Transportation .....	2-67
<b>3.0</b>	<b>INSTITUTIONAL AND REGULATORY FRAMEWORK.....</b>	<b>3-1</b>
3.1	Turkish Institutional Framework .....	3-1
3.1.1	Central Government Ministries .....	3-1
3.1.2	Provincial Administration (Bartın Province).....	3-3
3.1.3	Local Administration (Amasra District) .....	3-3
3.2	Turkish Regulatory Framework .....	3-3
3.2.1	Turkish Legal Framework .....	3-3
3.2.2	Applicable Turkish Environmental, Health, Safety and Social Legislation .....	3-4
3.2.3	International Conventions Ratified by Turkey that are Relevant to the Project .....	3-4
3.3	International Requirements .....	3-5
3.3.1	Equator Principles II .....	3-5
3.3.2	IFC Performance Standards .....	3-5
3.3.3	IFC Environmental, Health and Safety Guidelines .....	3-6
3.4.	Comparison of Turkish and International Environmental Thresholds .....	3-7
<b>4.0</b>	<b>SCOPE OF THE ESIA, PRIOR INVESTIGATIONS AND ENGAGEMENT ACTIVITIES .....</b>	<b>4-1</b>
4.1	Overview .....	4-1
4.2	Scoping Results.....	4-1
4.3	Applicable IFC PSs.....	4-4
4.4	Prior Investigations.....	4-5

4.4.1	Project Introduction File (PIF) for the HEMA Coal Washing Plants .....	4-6
4.4.2	Environmental Impact Assessment of the HEMA Port (Reclamation Area and Quay) .....	4-7
4.5	Stakeholder Engagement Activities during ESIA Study .....	4-8
<b>5.0</b>	<b>LAND USE AND ZONING .....</b>	<b>5-1</b>
5.1	Scope .....	5-1
5.2	Land Use Pattern .....	5-2
5.2.1	Shaft-1 area .....	5-3
5.2.2	Shaft-2 Area .....	5-6
5.2.3	Shaft-3 Area .....	5-8
5.2.4	HEMA Port Area .....	5-9
5.3	Land Ownership .....	5-11
5.3.1	Ownership of the Shaft and Port Areas .....	5-11
5.4	Expropriations .....	5-13
5.4.1	Expropriation Process .....	5-13
5.4.2	Expropriations requested by HEMA.....	5-17
5.4.3	Regional Plans and Zoning .....	5-18
5.5	Impacts.....	5-21
5.6	Mitigation Measures .....	5-23
<b>6.0</b>	<b>GEOLOGY AND SOILS .....</b>	<b>6-1</b>
6.1	Scope .....	6-1
6.2	Existing Environment.....	6-2
6.2.1	Geology and Tectonics .....	6-2
6.2.2	Soil Characteristics and Erosion .....	6-13
6.2.3	Soil Quality .....	6-15
6.3	Impacts.....	6-19
6.3.1	Impacts related to Geology and Seismicity.....	6-19
6.3.2	Impacts related to Soil .....	6-23
6.4	Mitigation Measures .....	6-25
6.5	Residual Impacts .....	6-27
<b>7.0</b>	<b>HYDROLOGY AND HYDROGEOLOGY .....</b>	<b>7-1</b>
7.1	Scope .....	7-1
7.2	Existing Environment.....	7-2
7.2.1	Water Balance.....	7-2
7.2.2	Groundwater Resources .....	7-3
7.2.3	Surface Water Resources .....	7-15
7.3	Impacts.....	7-18
7.3.1	Impacts on Groundwater Resources.....	7-18
7.3.2	Impacts on Surface Water Resources .....	7-20
7.4	Mitigation Measures .....	7-22
7.5	Residual Impacts .....	7-23

<b>8.0</b>	<b>MATERIAL RESOURCES AND WASTE MANAGEMENT.....</b>	<b>8-1</b>
8.1	Scope .....	8-1
8.2	Material Resources.....	8-1
8.3	Waste Management.....	8-4
8.4	Existing Waste Management Conditions in Bartın.....	8-5
8.4.1	Overview of Waste Generation .....	8-6
8.4.2	Waste Disposal and Treatment Facilities.....	8-6
8.5	Waste Generation and Waste Management during the Construction Phase .....	8-10
8.6	Waste Generation and Management during the Operation Phase.....	8-17
8.7	Impacts.....	8-25
8.8	Mitigation Measures.....	8-27
8.8	Residual Impacts .....	8-29
<b>9.0</b>	<b>MARINE ENVIRONMENT .....</b>	<b>9-1</b>
9.1	Scope .....	9-1
9.2	Existing Environment.....	9-2
9.2.1	Physical Oceanography .....	9-2
9.2.2	Marine Infrastructure .....	9-12
9.2.3	Marine Chemistry .....	9-14
9.3	Impacts during Construction and Operation.....	9-16
9.4	Mitigation Measures .....	9-17
9.5	Residual Impacts .....	9-18
<b>10.0</b>	<b>AIR QUALITY.....</b>	<b>10-1</b>
10.1	Scope .....	10-1
10.2	Legal Context.....	10-2
10.2.1	Air Quality Index.....	10-2
10.3	Climate and Meteorological Conditions.....	10-3
10.3.1	Temperature .....	10-3
10.3.2	Precipitation.....	10-3
10.3.3	Humidity and Pressure.....	10-4
10.3.4	Wind Characteristics .....	10-4
10.4	Air Quality Baseline Conditions.....	10-5
10.4.1	Background .....	10-5
10.4.2	Baseline Air Quality Measurements.....	10-5
10.5	Air Quality Modelling .....	10-7
10.5.1	Methodology.....	10-7
10.5.2	Emissions.....	10-8
10.5.3	Dispersion Modelling Results.....	10-10
10.6	Methane Gas Drainage and Recovery System .....	10-11
10.7	Green House Gases (GHGs) Estimations .....	10-12
10.8	Impacts.....	10-16

10.9	Mitigation .....	10-16
10.10	Residual Impacts .....	10-17
<b>11.0</b>	<b>NOISE.....</b>	<b>11-1</b>
11.1	Introduction .....	11-1
11.2	Definitions and Methodology .....	11-1
11.2.1	Definitions.....	11-1
11.2.2	Methodology.....	11-3
11.3	Environmental Noise Standards and Guidelines.....	11-6
11.3.1	Turkish Regulations.....	11-6
11.3.2	IFC Guidelines.....	11-7
11.4	Baseline Measurements.....	11-7
11.5	Noise Sources .....	11-8
11.5.1	Construction Noise.....	11-8
11.5.2	Operational Noise .....	11-15
11.6	Noise Mapping and Noise Modelling Results.....	11-16
11.6.1	Construction Phase .....	11-17
11.6.2	Operation Phase.....	11-18
11.6.2	Noise Modelling Results.....	11-22
11.7	Impacts.....	11-23
11.8	Mitigation.....	11-25
11.9	Residual Impacts .....	11-26
<b>12.0</b>	<b>ROAD TRANSPORTATION.....</b>	<b>12-1</b>
12.1	Scope .....	12-1
12.2	Transportation Network.....	12-1
12.2.1	Gomu-Tarlaagzi Village Road .....	12-2
12.2.2	Amasra - Ahatlar Road .....	12-4
12.2.3	Amasra - Bartın Road through Kazpinari Village .....	12-4
12.2.4	Bartın-Ankara State Road (No. D010) .....	12-5
12.2.5	Urban Road to Bartın Cement Factory.....	12-6
12.2.6	Amasra-Topderesi Road and Tunnel.....	12-6
12.3	Coal Transportation Demand .....	12-7
12.4	Optimum Transportation Itinerary.....	12-8
12.5	Mitigation Measures .....	12-9
12.6	Residual Impacts .....	12-11
<b>13.0</b>	<b>ECOLOGY AND BIODIVERSITY.....</b>	<b>13-1</b>
13.1	Scope .....	13-1
13.2	Legislative Framework.....	13-2
13.3	Legally Protected Sites and Key Biodiversity Areas.....	13-7
13.4	Terrestrial Flora .....	13-10

13.4.1	Methodology.....	13-10
13.4.2	Overview of Baseline Conditions .....	13-11
13.4.3	Terrestrial Flora Inventory of the Project Areas .....	13-12
13.4.4	Threat Status, Rareness and Endemism of Flora Species .....	13-12
13.4.5	Evaluation of the Flora Species According to HCV and IFC Standards.....	13-14
13.4.6	Terrestrial Ecosystem Characteristics .....	13-15
13.4.7	EUNIS Habitat Types in Project Areas .....	13-18
13.4.8	Impacts.....	13-19
13.4.9	Mitigation Measures.....	13-20
13.5	Fauna.....	13-21
13.5.1	Methodology.....	13-21
13.5.2	Baseline Conditions and Faunal Species Richness .....	13-22
13.5.3	Threat Status and Endemism of Faunal Species .....	13-23
13.5.4	Evaluation of the Fauna Species According to the HCVs and IFC Standards .....	13-25
13.5.5	Impacts.....	13-26
13.5.6	Mitigation Measures.....	13-28
13.6	Marine Ecology.....	13-29
13.6.1	Methodology.....	13-29
13.6.2	Overview of Baseline Conditions of Aquatic Ecosystem.....	13-30
13.6.3	Aquatic Organism Inventory of the Project Site .....	13-31
13.6.4	Threat Status, Rareness and Endemism of Aquatic Organisms.....	13-31
13.6.5	Fishing Activities within the Project Site.....	13-32
13.6.6	Impacts and Mitigation Measures .....	13-33
<b>14.0</b>	<b>SOCIO-ECONOMY .....</b>	<b>14-1</b>
14.1	Scope .....	14-1
14.2	Existing Conditions .....	14-2
14.2.1	Population and Demographics.....	14-2
14.2.2	Economy and Occupations.....	14-7
14.2.3	Employment.....	14-18
14.2.4	Income Distribution .....	14-19
14.2.5	Education .....	14-21
14.2.6	Recreation and Tourism.....	14-23
14.2.7	Health.....	14-26
14.2.8	Ports .....	14-27
14.3	Impacts.....	14-29
14.3.1	Direct and Indirect Employment Creation .....	14-29
14.3.2	Economy.....	14-32
14.3.3	Population.....	14-32
14.3.4	Social Environment and Infrastructure.....	14-33
14.3.5	Road and Ship Traffic .....	14-34



14.3.6	Expropriation and Resettlement.....	14-34
14.3.7	Fisheries and Aquaculture .....	14-35
14.3.8	Recreation and Tourism .....	14-35
14.4	Mitigations .....	14-36
14.5	Residual Impacts .....	14-37
<b>15.0</b>	<b>COMMUNITY HEALTH AND SAFETY .....</b>	<b>15-1</b>
15.1	Scope .....	15-1
15.2	Impacts and Risks .....	15-2
15.2.1	Water Use and Quality.....	15-2
15.2.2	Land Subsidence .....	15-2
15.2.3	Dust, Noise and Vibration .....	15-3
15.2.4	Community Health and Wellbeing.....	15-3
15.2.5	Emergency Preparedness and Response .....	15-4
15.2.6	Road Traffic.....	15-5
15.2.7	Vessel Traffic and Marine Safety .....	15-5
15.2.8	Visual Impacts .....	15-6
15.2.9	Infrastructure and Equipment Safety .....	15-8
15.2.10	Mine and Port Security Requirements.....	15-8
15.3	Mitigation Measures .....	15-9
15.4	Residual Impacts .....	15-10
<b>16.0</b>	<b>COMMUNITY HEALTH AND SAFETY .....</b>	<b>16-1</b>
16.1	Scope .....	16-1
16.2	Legal and Policy Context .....	16-2
16.2.1	IFC PS2: Labor and Working Conditions.....	16-2
16.2.2	International Labor Organization (ILO) Fundamental Conventions.....	16-3
16.2.3	Turkish Health and Safety Regulations .....	16-4
16.2.4	Human Resources (HR) Policy of HEMA.....	16-6
16.3	General Condition of Service.....	16-6
16.3.1	Employment Contract.....	16-6
16.3.2	Working Hours .....	16-7
16.3.3	Accommodation.....	16-8
16.4	Non-Discrimination .....	16-9
16.5	Grievance Mechanism.....	16-9
16.6	Child Labor and Forced Labor .....	16-9
16.7	Health and Safety.....	16-10
16.8	Non-employee Workers and Supply Chains.....	16-10
16.9	Impacts.....	16-11
16.10	Mitigation Measures.....	16-11
16.11	Residual Impacts .....	16-12
<b>17.0</b>	<b>CULTURAL HERITAGE .....</b>	<b>17-1</b>
17.1	Scope .....	17-1

17.2	Information Sources .....	17-2
17.2.1	Baseline Studies .....	17-2
17.2.2	Consultation with Relevant Regulatory Authorities .....	17-2
17.3	Regulatory Framework.....	17-3
17.4	Baseline Conditions .....	17-4
17.4.1	Brief Literature Survey .....	17-4
17.4.2	Surface Reconnaissance Surveys at Licensed Area .....	17-6
17.5	Consultation with Relevant Regulatory Authorities and Archaeological Investigations.....	17-10
17.6	Impacts.....	17-12
17.7	Mitigation Measures .....	17-13
<b>18.0</b>	<b>ENVIRONMENTAL AND SOCIAL MANAGEMENT .....</b>	<b>18-1</b>
18.1	Environmental, Health and Safety and Social Policy.....	18-2
18.2	ESMS Planning.....	18-2
18.2.1	Environmental, Health and Safety and Social Aspect/Risk Assessment .....	18-2
18.2.2	Legal and Other Requirements .....	18-3
18.2.3	Targets, Objectives and Programs .....	18-3
18.3	Implementation of the ESMS .....	18-3
18.3.1	Responsibilities, Resources and Training .....	18-3
18.3.2	Communication.....	18-4
18.3.3	Documentation and Document Control .....	18-4
18.3.4	Operational control.....	18-5
18.3.5	Environmental and Social Emergency Preparedness and Response .....	18-6
18.4	ESMS Control.....	18-7
18.4.1	Monitoring, Measurement and Review .....	18-7
18.4.2	Non-conformities and Corrective, Preventive and Improving Actions .....	18-7
18.4.3	Data Control.....	18-7
18.4.4	Management Review .....	18-7
18.5	Stakeholder Engagement .....	18-8
18.6	Grievance Management.....	18-9

## ANNEXES

- Annex A: Official Correspondence/Opinion Letters related to Turkish EIA Requirements
- Annex B: Amasra Hard Coal Production Project Report by SRK, October 2013
- Annex C: Environmental, Health and Safety and Social (EHSS) Legislation Review
- Annex D: Environmental and Social Management Plan (ESMP)
- Annex E: Land Use and Zoning Supporting Information
- Annex F: Geology, Soils and Contaminated Land Supporting Information
- Annex G: Hydrology and Hydrogeology Supporting Information
- Annex H: Waste Management Plan
- Annex I: Air Quality Modelling Report
- Annex J: Noise Modelling Report
- Annex K: Traffic Study
- Annex L: Flora and Fauna List
- Annex M: HEMA Hard Coal Mine Stakeholder Communications Plan
- Annex N: Labor and Working Conditions Supporting Information
- Annex O: Cultural Heritage Site Assessment Report

## LIST OF TABLES

Table 1-1: Criteria used to determine the impact magnitude.....	1-6
Table 1-2: Criteria related to value/sensitivity of the resources/receptors.....	1-7
Table 1-3: Evaluation of significance .....	1-8
Table 2-1: Hard coal production and consumption data in Turkey (million tonnes).....	2-5
Table 2-2: Measured, indicated, inferred and total resource estimations at HEMA production blocks .....	2-8
Table 2-3: Characteristics of production blocks .....	2-8
Table 2-4: Chemical analysis of Amasra coals .....	2-9
Table 2-5: Tentative construction program for aboveground facilities for coal mining .....	2-16
Table 2-6: Excavation-concrete comparison at shafts.....	2-20
Table 2-7: Technical characteristics of installed shafts .....	2-20
Table 2-8: Galleries of the East Production Block.....	2-26
Table 2-9: Galleries of the West Production Block.....	2-27
Table 2-10: Galleries of the Southeast Production Block .....	2-27
Table 2-11: Liberated methane measurement at TTK colliery drifts in 1997 .....	2-39
Table 2-12: Air compressors to be installed at the mine site .....	2-40
Table 2-13: Water pumps to be installed at the mine site .....	2-42
Table 2-14: Energy demand of the mining project by years (in MVA) .....	2-43
Table 2-15: Distribution of workforce currently employed.....	2-45
Table 2-16: Labor requirement by years for west block shallow coal mining.....	2-47
Table 2-17: Labor requirement by years for underground mining works .....	2-48
Table 2-18: Ports in Bartın Province .....	2-54
Table 2-19: Properties of the berthing structures.....	2-56
Table 2-20: HEMA port coal storage areas .....	2-60
Table 2-21: HEMA port land facilities .....	2-60
Table 2-22: HEMA port infrastructure facilities.....	2-61
Table 2-23: Characteristics of the cargo vessels to be used in the project .....	2-63
Table 2-24: Port project tentative implementation schedule .....	2-64
Table 2-25: Summary of operational equipment deployment.....	2-66
Table 2-26: HEMA port structure of employment.....	2-67
Table 4-1: Applicable IFC PSs .....	4-5
Table 5-1: Distances of the main components of the Project .....	5-3
Table 5-2: Total surface areas and locations of parcels owned by HEMA.....	5-11
Table 5-3: Total surface areas and locations of parcels requested for expropriations .....	5-18
Table 6-1: Earthquakes that occurred in the vicinity of Amasra in the last 100 years.....	6-12
Table 6-2: Analytical results for soil contaminants (Segal study) .....	6-16

Table 6-3: Analytical results for soil fertility (Segal study) .....	6-17
Table 6-4: Analytical results for soil constituents (Ege University study).....	6-18
Table 7-1: Amasra District meteorological data .....	7-2
Table 7-2: Amasra District meteorological balance sheet.....	7-3
Table 7-3: Sampling identification and coordinates of groundwater sampling points .....	7-9
Table 7-4: Groundwater samples and laboratory analysis results, February, 2012 .....	7-12
Table 7-5: Electrical conductivity, pH, temperature, flow rate and static level measurements .....	7-13
Table 7-6: Results of chemical analysis.....	7-13
Table 7-7: Bartın Province surface water potential.....	7-16
Table 7-8: Bartın province hydrological measurements.....	7-17
Table 7-9: Surface water samples and laboratory analysis results.....	7-18
Table 8-1. Main Material Items for Mining Activities .....	8-1
Table 8-2. Total concrete volume for shafts constructions .....	8-2
Table 8-3. Total water consumption of the Project.....	8-3
Table 8-4. Steps of the sea water treatment and aims of the processes .....	8-4
Table 8-5. Waste Generation in Bartın Province and Amasra District.....	8-6
Table 8-6. Licensed Waste Management (Recycling / Disposal) Facilities located in Bartın Province .....	8-7
Table 8-7. Licensed Waste (Recycling / Disposal) Facilities located near Bartın Province .....	8-8
Table 8-8. Types of waste and proposed management practices during construction phase of the Project.....	8-11
Table 8-9. Excavated volume during shaft constructions.....	8-15
Table 8-10. Excavation volume during Coal Washing Plant construction and reclamation activities.....	8-15
Table 8-11. Industrial Wastewater generation during the construction phase .....	8-16
Table 8-12. Waste types and proposed management practices during operation phase of the Project.....	8-19
Table 8-13. Industrial wastewater cycle during the operation phase .....	8-24
Table 9-1: Current Station Coordinate.....	9-8
Table 9-2: Grain Size Analysis Results .....	9-11
Table 9-3: Analysis Results of the Parameters.....	9-15
Table 10-1: EU Council Directive 2008/50/EC, Turkish ambient air quality standards (as per RAMAQ Annexes 1 and 1A and IAPCR Annex 2) and IFC standards .....	10-2
Table 10-2: Air quality index of main pollutants) .....	10-3
Table 10-3: Average temperature data for a period of 41 years (1970-2011) .....	10-3
Table 10-4: Average precipitation data for a period of 41 years (1970-2011).....	10-4
Table 10-5: Relative humidity and pressure data for a period of 41 years (1970-2011).....	10-4
Table 10-6: Monthly average wind speed between the years 1970-2011 .....	10-4

Table 10-7: Average concentrations of air pollutants (SO <sub>2</sub> and PM <sub>10</sub> ) in Bartın province in 2013	10-5
Table 10-8: PM deposition sampling results.....	10-6
Table 10-9: PM <sub>10</sub> sampling results .....	10-6
Table 10-10: Gaseous pollutant sampling results.....	10-6
Table 10-11: Emission Factors Used to Calculate Dust Emissions .....	10-8
Table 10-12: Dust emissions calculations for earthwork activities .....	10-9
Table 10-13: Dust emissions calculations for earthwork activities .....	10-9
Table 10-14: Maximum GLC Values Determined from the Modeling Studies.....	10-10
Table 10-15: Maximum GLC Values Determined from the Modeling Studies.....	10-11
Table 10-16: Emission factors for the consumption of coal mine waste gas that is captured for combustion .....	10-12
Table 10-17: Methane and GHGs emissions based on annual productions of Amasra Coal Mine	10-14
Table 11-1: Environmental noise limits for construction sites .....	6
Table 11-2: Environmental Noise Limits for Industrial Facilities (Leq-dBA) .....	6
Table 11-3: IFC noise level guidelines (one hour Leq-dBA) .....	7
Table 11-4: Results of Baseline Noise Measurements.....	8
Table 11-5: Results of Hourly Baseline Noise Measurements.....	8
Table 11-6: Machine and Equipment for Construction Activities.....	12
Table 11-7: Sound Power Level Calculations of Construction Machines/Equipment and Total Sound Power Level for Construction Phase .....	12
Table 11-8: C <sub>f</sub> value of the fan .....	14
Table 11-9: Corrections for f value of the fan.....	14
Table 11-10: Sound Power Level of Ventilation Fans (each fan) .....	14
Table 11-11: Machine and Equipment for Operation Activities .....	15
Table 11-12: Sound Power Level Calculations of Operation Phase .....	15
Table 11-13: Transmission Loss Value (Louver).....	16
Table 11-14: Noise Modeling Results on Nearest Receptor (Highest Noise Levels).....	11-22
Table 11-15: Noise Modeling Results on Measurement Locations .....	11-22
Table 11-16: Noise Modeling Results (Hourly) .....	11-22
Table 12-1: Amount of Coal to be Transported .....	12-7
Table 12-2: Number of Coal Carrying Trucks .....	12-8
Table 12-3: Number of employee shuttle services (daily-bidirectional) .....	12-8
Table 13-1. IUCN Red List Categories and Criteria.....	13-3
Table 13-2. The relation between High Conservation Value Types and Performance Standard 6	13-7
Table 13-3. Distribution coordinates of the endemic and rare species within the Project Areas.....	13-14
Table 13-4. Quantitative Thresholds for Tier 1 and Tier 2.....	13-15
Table 13-5. Characteristics of the Forest Ecosystem .....	13-16
Table 13-6. Characteristics of the Forest Ecosystem .....	13-18

Table 13-7. Plant species which can be used for restoration and plantation activities .....	13-21
Table 13-8 Threatened fish species within the HEMA Reclamation Area and Quay	
Project Area .....	13-32
Table 14-1: Number of Conducted Questionnaires.....	14-2
Table 14-2: Population of Bartın Province and its districts between 2000 and 2013 .....	14-4
Table 14-3: Location and population data of three nearby settlements in the vicinity of the Project area.....	14-4
Table 14-4: Migration data of Bartın Province between 1995 and 2013 .....	14-5
Table 14-5: Population by age group in Bartın Province and Amasra District.....	14-6
Table 14-6: General demographic indicators of Bartın and Amasra as compared to Turkey .....	14-6
Table 14-7: Population distribution of Bartın and Amasra by marital status and gender.....	14-7
Table 14-8: Vulnerability of respondent households .....	14-7
Table 14-9: Socio-economic indicators of Bartın as compared to Turkey.....	14-8
Table 14-10: Type and number of enterprises in Bartın Province as of 2012 .....	14-8
Table 14-11: Main economic activities in the settlements* .....	14-9
Table 14-12: Overview of some agricultural activities in Bartın Province .....	14-10
Table 14-13: Overview of some agriculture activities in Amasra District.....	14-10
Table 14-14: Agricultural products in surveyed area.....	14-11
Table 14-19: The list of the fish species (written in Latin) in Bartın Province .....	14-12
Table 14-20: Some fishery statistics in Bartın Province.....	14-12
Table 14-21: Importance of fishing for households.....	14-14
Table 14-15: Greenhouse cultivation in Amasra .....	14-14
Table 14-16: Some animal breeding activities and animal products in Bartın in 2013 .....	14-15
Table 14-17: Some animal breeding activities and animal products in Amasra District in 2013 ..	14-15
Table 14-18: Animal breeding in surveyed area .....	14-15
Table 14-22: Mining business facilities in Bartın Province .....	14-17
Table 14-23: Employment data for Turkey, West Black Sea Region and Bartın Province .....	14-18
Table 14-24: Comparison of population distribution by working sectors in Zonguldak, Karabuk, Bartın sub-region* and Turkey.....	14-18
Table 14-25: Distribution of occupational groups in Gomu, Tarlaagzi, Kazpinari Villages and Kum Neighbourhood .....	14-18
Table 14-26: Availability and location of jobs .....	14-19
Table 14-27: Main source of income for households .....	14-20
Table 14-28: Poverty comparison of Turkey and West Black Sea Region .....	14-20
Table 14-29: Educational status of Bartın Province.....	14-21
Table 14-30: Educational status of the Amasra District .....	14-22
Table 14-31: Courses and enrollment in 2012 in Bartın Province and Amasra District .....	14-23
Table 14-32: Municipality licensed accommodation establishments in Bartın Province .....	14-24

Table 14-33: Number of Employees in Tourism Sector .....	14-24
Table 14-34: Ministry of tourism licensed accommodation establishments in Bartın central district.....	14-24
Table 14-35: Main Types of Activities for Tourism Revenue .....	14-25
Table 14-36: Importance of tourism for households.....	14-25
Table 14-37: Healthcare service locations being utilized by people live near the project area....	14-26
Table 14-38: The number of boats both using Tarlaağzı fishing port.....	14-28
Table 15-1: Classification for the Impact Significance of Land Subsidence .....	15-3
Table 15-2: Degree of Risk and Acceptability Criteria .....	15-7
Table 15-3: Degree of Risk and Acceptability Criteria .....	15-7
Table 16-1: Requirements under IFC PS2 .....	16-2
Table 16-2: ILO Fundamental Conventions.....	16-3



## LIST OF FIGURES

Figure 2-1: Project site map .....	2-2
Figure 2-2: Profile of the Project site .....	2-2
Figure 2-3: Hard Coal Mine Production Blocks .....	2-7
Figure 2-4: Aerial view of shaft locations and nearby settlements .....	2-10
Figure 2-5: Aerial view of Shaft-1 location before and after mine development activities .....	2-11
Figure 2-6: Aerial view of Shaft-2 location before and after mine development activities .....	2-11
Figure 2-7: Aerial view of Shaft-3 location before and after mine development activities .....	2-11
Figure 2-8: Graph showing overall production by years at West, East and Southeast Production Blocks .....	2-12
Figure 2-9: Graph showing overall production of shallow coals by years .....	2-13
Figure 2-10: Shaft-1 general layout .....	2-17
Figure 2-11: Shaft-2 general layout .....	2-18
Figure 2-12: Shaft-3 general layout .....	2-19
Figure 2-13: Cross-sectional views of Shafts-1, 2 and 3 .....	2-21
Figure 2-14: Sectional drawing of Shaft-1.....	2-22
Figure 2-15: Shaft-1 bottom layout (-510 level) .....	2-23
Figure 2-16: Sectional drawing of Shaft-2 .....	2-24
Figure 2-17: Sectional drawing of Shaft-3 .....	2-25
Figure 2-18: 18 m <sup>2</sup> and 24 m <sup>2</sup> galleries typical cross-sectional views.....	2-26
Figure 2-19: Coal, material and personnel transportation plan .....	2-31
Figure 2-20: Typical longwall equipment.....	2-32
Figure 2-21: Typical set-up for longwall mining process .....	2-33
Figure 2-22: Schematical representation of the longwall mining process .....	2-33
Figure 2-23: Pack Wall System.....	2-36
Figure 2-24: Control, communication and the monitoring system .....	2-42
Figure 2-25: Locations of proposed spoil disposal sites 1 and 2. ....	2-45
Figure 2-26: Location of the proposed port project .....	2-53
Figure 2-27: Location of the port with respect to the Shaft-1 area.....	2-54
Figure 2-28: Ports/fishery ports in the area .....	2-55
Figure 2-29: HEMA port general layout and components.....	2-56
Figure 2-30: Breakwater cross-section .....	2-57
Figure 2-31: Bulk cargo quay general layout .....	2-58
Figure 2-32: Quay structure cross-section.....	2-59
Figure 2-33: Stacking at coal stocking yards using stacker-reclaimer (typical) .....	2-60
Figure 2-34: Slope area behind the quay.....	2-62
Figure 5-1: General view of the Project Components .....	5-2

Figure 5-2: Overall view of Project components around Shaft-1 area .....	5-4
Figure 5-3: Distribution of influenced areas in the vicinity of Shaft-1.....	5-6
Figure 5-4: Overall view of Shaft-2 area .....	5-7
Figure 5-5: Overall view of Project components around Shaft-3 area .....	5-9
Figure 5-6: Overall view of Project components around HEMA Port area.....	5-10
Figure 5-7: The identification of current situation of parcels around Shaft-1 area.....	5-12
Figure 5-8: The identification of current situation of parcels around Shaft-2 area.....	5-12
Figure 5-9: The identification of current situation of parcels around Shaft-3 area.....	5-13
Figure 5-10: The land sections requested for expropriation around Shaft-1 area.....	5-17
Figure 5-11: Section of 1/100,000 scaled Zonguldak-Bartın-Karabuk Planning Zone Environmental Plan .....	5-19
Figure 5-12: Section of 1/25,000 scaled Zonguldak-Bartın-Karabuk Planning Zone Environmental Plan around Shaft 1 and HEMA port .....	5-20
Figure 5-13: Section of 1/25,000 scaled Zonguldak-Bartın-Karabük Planning Zone Environmental Plan around Shaft 3 .....	5-20
Figure 6-1: Regional geological map .....	6-2
Figure 6-2: Generalized stratigraphic column of Amasra basin.....	6-3
Figure 6-3: Geological map of licensed area.....	6-6
Figure 6-4: Geological cross-section of the licensed area (Southwest – Northeast).....	6-8
Figure 6-5: Geological cross-section of the licensed area (West - East).....	6-9
Figure 6-6: Fault map of Amasra .....	6-11
Figure 6-7: Seismic zone classification map of Bartın Province.....	6-12
Figure 6-8: Seismic activity map of Amasra and the vicinity .....	6-13
Figure 6-9: Soil classification map of Bartın Province.....	6-14
Figure 6-10: Soil capability classes of Bartın Province .....	6-15
Figure 6-11: Soil sampling locations (Segal study).....	6-16
Figure 6-12: Soil sampling locations (Ege University study) .....	6-19
Figure 6-13: Cross-section of a typical longwall face.....	6-20
Figure 6-14: Development of a subsidence trough (to an exaggerated vertical scale).....	6-20
Figure 6-15: Settlement areas above coal production blocks .....	6-22
Figure 7-1: Generalized stratigraphic column of Amasra basin.....	7-4
Figure 7-2: General cross-section of Amasra hard coal basin formation and aquifer system .....	7-5
Figure 7-3: Carstic water outlet in the west of Delikli Cape .....	7-6
Figure 7-4: Geological – hydrogeological relationship of wells HEMA2, HSK1 and 13 with Kavsak Creek and Selen Spring .....	7-6
Figure 7-5: Area map showing groundwater sampling points, ‘Mandatory and Short Distance Protection Zones’ and the feed area of Selen Spring, Kavsak Creek and Well 13 including HEMA Port.....	7-8

Figure 7-6: Area map showing feed area of Selen Spring, Kavsak Creek and Well 13, ‘Mandatory and Short Distance Protection Zones’ and reference points to HEMA Wells.....	7-8
Figure 7-7: Location map of groundwater sampling points in relation to Project Shafts 1, 2 and 3 .....	7-10
Figure 7-8: Groundwater sampling points location map.....	7-11
Figure 7-9: Some of the water resources included in the study.....	7-11
Figure 7-10: Na/ (Na+Ca) weight ratio versus logarithmic function of suspended matter .....	7-15
Figure 7-11: Surface water resources in Bartın Province .....	7-16
Figure 8-1: On-site Package Wastewater Treatment Plant at the Port .....	8-17
Figure 9-1: Bathymetry Map of the Region .....	9-3
Figure 9-2: General bathymetric properties of the Project Area .....	9-3
Figure 9-3: Seismic location map.....	9-4
Figure 9-4: Seismic time section and evaluation of H1.....	9-5
Figure 9-5: Seismic time section and evaluation of H11.....	9-5
Figure 9-6: Seismic time section and evaluation of H17.....	9-6
Figure 9-7: Seismic time section and evaluation of H18.....	9-6
Figure 9-8: Side-scan sonar study routes and covering areas .....	9-7
Figure 9-9: Locations of Oceanographic Measurements.....	9-7
Figure 9-10: Current direction/time .....	9-8
Figure 9-11: Current velocity/time .....	9-9
Figure 9-12: Current velocity- direction scattering plot .....	9-9
Figure 9-13: Digital bathymetry for wave transformation modelling and observation profile along -20 m contour .....	9-10
Figure 9-14: Locations of Sediment Measurements.....	9-11
Figure 9-15: Sediment Distribution Map .....	9-12
Figure 9-16: HEMA port general layout.....	9-13
Figure 9-17: Sampling Stations .....	9-14
Figure 10-1: Annual wind diagram(A) and number of long-term wind blowings (B) .....	10-5
Figure 10-2: Dispersion of PM <sub>10</sub> and PM deposition GLC values .....	10-10
Figure 10-3: Maximum 8-Hour Average GLC Dispersion of CO Emission .....	10-11
Figure 11-1: Terrain Levels of the Project Area .....	11-4
Figure 11-2: Wind Directions for Amasra .....	11-4
Figure 11-3: Background noise sampling locations .....	11-7
Figure 11-4: Shaft – 1 Layout .....	11-9
Figure 11-5: Shaft – 2 Layout .....	11-10
Figure 11-6: Shaft – 3 Layout .....	11-11
Figure 11-7: 3D Model of Project Area .....	11-17
Figure 11-8: Noise Propagation Model for Construction with Satellite view .....	11-18

Figure 11-9: Noise Propagation Model for Operation (Road) .....	11-19
Figure 11-10: Noise Propagation Model for Operation with Satellite view .....	11-20
Figure 11-11: Noise Propagation Model for Operation with 3D Satellite view .....	11-21
Figure 12-1: Transportation network in the Project area.....	12-2
Figure 12-2: Gomu – Tarlaagzi Village Road .....	12-3
Figure 12-3: Village Road-Amasra-Bartın Road Junction Point .....	12-4
Figure 12-4: Amasra - Bartın Road.....	12-5
Figure 12-5: Bartın-Ankara Road .....	12-6
Figure 12-6: Urban Road to Bartın Cement Factory .....	12-6
Figure 12-7: Amasra-Topderesi road and tunnel.....	12-7
Figure 12-8: Route to Bartın Cement Plant .....	12-9
Figure 13-1. Legally protected sites in the licence area and its surroundings.....	13-9
Figure 13-2. Productive forest and secondary products in the licence area and its surroundings .	13-9
Figure 13-3. Amasra Coastline Key Biodiversity Area .....	13-10
Figure 13-4. Closest IBA to the licence area .....	13-10
Figure 13-5. Deciduous forest vegetation .....	13-12
Figure 13-6. Deciduous forest vegetation .....	13-12
Figure 13-7. Evergreen maquis vegetation.....	13-12
Figure 13-8. <i>Pinus nigra</i> plantations .....	13-12
Figure 13-9. <i>Seseli resinosum</i> .....	13-13
Figure 13-10. <i>Euonymus latifolius subsp. Cauconis</i> .....	13-13
Figure 13-11. <i>Campanula lyrata subsp. lyrata</i> .....	13-13
Figure 13-12. <i>Laurus nobilis</i> .....	13-16
Figure 13-13. <i>Arbutus unedo</i> .....	13-17
Figure 13-14. <i>Helloborus orientalis</i> .....	13-17
Figure 13-15. <i>Cyclamen coum</i> .....	13-17
Figure 13-16. General overview of a natural habitat within the Project Areas.....	13-22
Figure 13-17. Waste rock dumpsites near the Shaft-1 .....	13-22
Figure 13-18. Some bird species identified at Project Areas.....	13-24
Figure 13-19. A water body within the waste rock dumpsite near the Shaft-2 .....	13-27
Figure 13-20. Sampling stations.....	13-30
Figure 13-21. Tarlaagzı Fishing Port.....	13-32
Figure 14-1: National population of Turkey between 1965 and 2013 .....	14-3
Figure 14-2: Population of Bartın between 2000 and 2013 .....	14-3
Figure 14-3: Aquaculture production by provinces, 2012 .....	14-11
Figure 14-4: Amasra District Aquaculture Production Area .....	14-13
Figure 14-5: Areas where bottom trawling is prohibited .....	14-13
Figure 14-6: Turkey’s coal consumption and production, 2001-2012 (million short tons). .....	14-17

Figure 14-7: Distribution of educational enrollment..... 14-23

Figure 17-1: Distribution of Archeological Sites in Amasra District Center ..... 17-5

Figure 17-2: Section of 1/25,000 scaled Zonguldak-Bartın-Karabük Planning Zone  
                   Environmental Plan around Port Area ..... 17-6

Figure 17-3: The location of Bird’s Rock Road Monument..... 17-8

## ABBREVIATIONS

ABA	Acid Base Accounting
ACWP	Amasra Mine Coal Washing Plant
AFC	Armored Face Conveyor
AoI	Area of Influence
APELL	Awareness and Preparedness for Emergencies at Local Level
ATI	Amasra Hard Coal Enterprise
BAO	Biodiversity Action Plan
BERN	Bern Convention
°C	Celsius
CDT	Conductivity, temperature and density
CITES	Convention on International Trade in Endangered Species of Wild Fauna and Flora
CH <sub>4</sub>	Methane
CO	Carbon Monoxide
CO <sub>2</sub>	Carbon Dioxide
CWP	Coal Washing Plants
DCS	Doppler Current Sensor
DF	Dental Fluorosis
DMI	State Meteorological Works
DO	Dissolved Oxygen
DSI	State Hydraulic Works
DWT	Dead Weight Tonnes
EHS	Environmental Health and Safety
EHSS	Environmental, Health and Safety and Social
EIA	Environmental Impact Assessment
EPRP	Emergency Preparedness and Response Plan
EPs	Equator Principles
EIA	Environmental Impact Assessment
ESIA	Environmental and Social Impact Assessment
ESMP	Environmental and Social Management Plan
ESMS	Environmental and Social Management System
ESR	Ecosystem Services Review
ETP	Evapo-Transpiration
EU	European Union
°F	Fahrenheit
FIs	Financial Institutions
FSC	Forest Stewardship Council
GDP	Gross Domestic Product

GTIS	Gross Tonnes In-Situ
H <sub>2</sub> S	Hydrogen Sulfur
h	Hour
ha	Hectare
HCV	High Conservation Value
HDPE	High Density Polyethylene
hm <sup>3</sup>	Cubic Hectometers
HL	Hydraulic Laboratory
HR	Human Resources
IBA	Important Bird Areas
IFC	International Finance Corporation
ILO	International Labor Organization
IMS	Integrated Management System
ISO	International Organization for Standardization
ISPS	International Ship and Port Facility Security
ITU	Istanbul Technical University
IUCN	International Union for the Conservation of Nature
JSA	Job Safety Analysis
KBA	Key Biodiversity Areas
kcal	Kilocalori
kg	Kilogram
km	Kilometer
km <sup>2</sup>	Square Kilometer
kV	Kilovolt
kVa	Kilovolt Ampere
KVSD	Short Term Limit Value
kW	Kilowatt
kWh	Kilowatt hour
L&FS	Life and Fire Safety
LPG	Liquefied Petroleum Gas
LPM	Liter per Minute
lt	Liter
m	Meter
m <sup>2</sup>	Square Meter
m <sup>3</sup>	Cubic Meter
mm	Millimeter
MAK	Central Game Commission
MEUP	Ministry of Environment and Urban Planning
MFWW	Ministry of Forestry and Water Affairs

mg	Milligram
ML	Metals Leaching
Mt	Million Tonnes
MTA	Mineral Research and Exploration
MVA	Mega Volt Ampere
MW	Megawatt
N	Newton
NAF	National Anatolian Fault
NCB	National Coal Board
ND	Not Detected
NFPA	National Fire Protection Association
NGO	Non-Governmental Organization
O <sub>2</sub>	Oxygen
OG	Official Gazette
OHSAS	Occupational Health and Safety Management System
OIZ	Organize Industrial Zone
PA	Parking Area
PAF	Potentially Acid Forming
PAG	Potentiall Acid Generating
PE	Polyethylene
PIF	Project Information File
PPE	Personal Protective Equipment
PS	Performance Standard
PWWTP	Package Biological Wastewater Treatment Plants
RO	Reverse Osmosis
RSPC	Regulation on soil Pollution Control
ROM	Run of Mine
SCWP	Shallow Mine Coal Washing Plant
SE	Southeast
Sec	Second
SEC	Southeast Coal
SEP	Stakeholder Engagement Plan
SLA	Social Labor Audit
SO <sub>2</sub>	Sulfur Dioxide
SS	Soil Sampling
SWI	Safe Working Instructions
SWQM	Surface Water Quality Management
SWQR	Swimming Water Quality Regulation
TEIAS	Turkish Electricity Transmission Company



TKI	Turkish Coal Enterprise
TJ	Terajoule
TOX	Total Organic Halogens
TPH	Tonnes Per Hour
TPH	Total Petroleum Hydrocarbons
TPAO	Turkish Petroleum Corporation
TSE	Turkish Standards Institution
TSI/(TUIK)	Turkish Statistical Institute
TTIS	Total Tonnes In-Situ
TTK	Turkish Hard Coal Enterprise
UN	United Nations
UNESCO	United Nations Educational, Scientific and Cultural Organization
U.S.	United States
UTM	Universal Transverse Mercator
VU	Vulnerable
WA	Westphalia-A
WC	Westphalia-C
WIHC	Water Intended for Human Consumption
WMP	Waste Management Plan
WPCR	Water Pollution Control Regulation
WSC	West Shallow Coal
WWTP	Wastewater Treatment Plant
µg	Microgram
µS	Micro Siemens

## 1.0 INTRODUCTION

### 1.1 Background and Objective

An Environmental and Social Impact Assessment (ESIA) study has been conducted for the “Amasra Hard Coal Production Project” (Project) located in the Amasra District of Bartın Province in the West Blacksea Region of Turkey (Figure 1-1). The Project is being developed by Hattat Enerji ve Maden Ticaret A.S. (HEMA), a subsidiary of Hattat Holding. HEMA has been awarded the Amasra Hard Coal Mine Field B (Subfields A and B).



Figure 1-1: Project location with Amasra Hard Coal Mine Field B mining license area boundaries shown in red and project components

The Project will have the following main components: (1) underground hard coal mine within Amasra A (Shallow Mine) and B Fields (Deep Mine), (2) Port (Reclamation Area and Quay), and (3) Coal Washing Plants and waste disposal facilities. Auxiliary facilities within the scope of the Project will include the slope protection area behind the quay and three power transmission lines. Further details of the Project are provided in *Chapter 2: Project Description*.

HEMA is seeking financing from financial institutions (FIs) to fund the development of the Project. In order to meet the requirements of FIs, HEMA has commissioned ELC Group Consulting and Engineering Inc. (ELC) to undertake the ESIA study.

The purpose of the ESIA study provide a detailed project description, identify the environmental and social impacts that may occur as a result of the Project development and operation and determine mitigation measures that can be taken to avoid and/or minimize the adverse impacts and maximize benefits. This document represents the Final Draft ESIA report which has been prepared in line with the FI requirements.

## 1.2 Turkish Environmental Impact Assessment Requirements

Pursuant to the Turkish Environmental Impact Assessment (EIA) Regulation (Official Gazette date/number: 25.11.2014/29186), an EIA or a Project Description File may be required depending on the type of the project, its capacity, or the location of the activity. Based on classification of projects according to the potentially expected environmental impacts, the projects listed in Annex-I of the regulation are directly subject to prepare a full EIA Report and they should first apply to Ministry of Environment and Urban Planning (MEUP) with an EIA Application File. The projects listed in Annex-II should prepare a Project Description File and are subject to screening by MEUP to derive a decision whether or not a full EIA is needed.

The EIA status of the Project components are given below:

**Underground Hard Coal Mine within Amasra A and B Sub-Fields (Shallow and Deep Mining):** According to the official letter of Bartın Provincial Directorate of Environment and Forestry (changed as Bartın Provincial Directorate of Environment and Urban Planning) dated 15.07.2008, underground Hard Coal Mine Project (within Amasra B field) was exempted from the Turkish EIA Regulation valid at the time (EIA Regulation published in the Official Gazette dated 16.12.2003 and numbered 25318) based on the condition that the Project has obtained its operation license before 07.02.1993 (enactment date of the first EIA Regulation in Turkey) as described in the Temporary Article 3 of the mentioned regulation.

**Port (Reclamation Area and Quay):** Port Component consisting of the Reclamation area and quay project was assessed according to the Turkish EIA Regulation (Official Gazette Date/Number: 17.07.2008/26939) under Annex-1 article 10-b: Commercial ports, jetties and quays where marine vessels over 1,350 dead weight tonnes (DWT) can dock. The Final EIA Report for the Project was submitted to the MEUP in April 2013 and the final presentation was held on 07.01.2014. EIA is currently under approval process.

**Coal Washing Plants and waste disposal facilities:** Coal Washing Plants were assessed according to the Turkish EIA Regulation (Official Gazette: 03.10.2013/28784) under Annex-2, Article 55-Mining Projects e) Ore processing plants, f) Ore enrichment plants and/or related waste facilities (that are

not listed under Annex-1); and Annex-2, Article 57-Coal Processing Plants: c) Coal Washing Plants. A Project Information File (PIF) was submitted to the Bartın Provincial Directorate of Environment and Urban Planning in January 2014 and “EIA is not required” document was obtained on 27.01.2015.

Prior investigations related with the Project are described in *Chapter 4: Scope of ESIA and Prior Investigations and Engagement Activities*.

### **1.3 ESIA Requirements**

HEMA has undertaken an ESIA study for identifying potential environmental and social impacts and risks of the Project and developing mitigation measures appropriate to the nature and scale of the Project. The mitigation measures need to be included in an accompanying Environmental and Social Management Plan (ESMP). The ESIA report and the ESMP will then be used as a basis by the lenders for the environmental and social appraisal of the Project. The ESIA study has been conducted to meet the requirements of the following international standards:

- Equator Principles II (June 2006)
- IFC Performance Standards on Social and Environmental Sustainability (January 2012)
- IFC General Environmental, Health and Safety Guidelines (April 2007)
- IFC Environmental, Health and Safety Guidelines for Mining (December 2007)
- IFC Environmental, Health, and Safety Guidelines for Waste Management Facilities (December 2007)
- IFC Environmental, Health and Safety Guidelines for Ports, Harbors and Terminals (April 2007)

In addition to these standards, the Project must comply with Turkish environmental and social legislations. The applicable national laws and regulations have been compiled in a regulatory framework document provided in Annex C, including a brief overview of key EU Directives that may be relevant to the Project.

### **1.4 Key Steps in the ESIA process**

#### **1.4.1 Overview**

The integration of environmental and social considerations into the project cycle is an essential part of all projects that aim to contribute to sustainable development. An ESIA process is accepted as being the most effective way of achieving this integration. ESIA is a systematic process that predicts and evaluates the impacts of a project on various aspects of the physical, biological, cultural and socioeconomic environment. This is followed by the identification of appropriate mitigation measures to avoid, reduce, remedy, offset or compensate for adverse impacts relevant to the nature and scale of the project. The key steps of the ESIA process are presented in Figure 1-2.

#### **1.4.2 Screening**

The first step in the ESIA process is the screening stage which determines whether an impact assessment is required to be undertaken for a specific project. This is in general determined by referring to the FIS categorization lists, including types of activities and if the project activity is found to be included in these lists, then an ESIA is undertaken. HEMA undertook the ESIA study based on engagement with potential lenders.

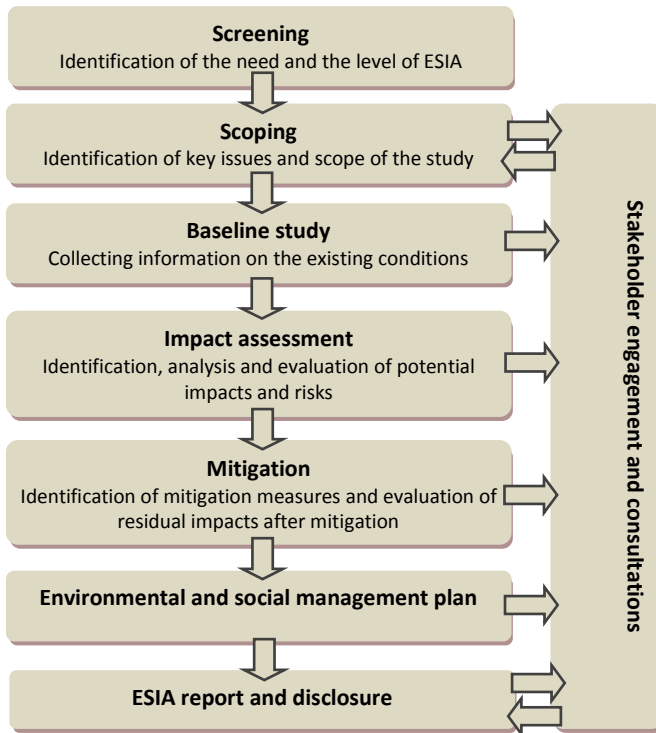

Figure 1-2: ESIA process

### 1.4.3 Scoping

Scoping is a crucial step in an ESIA process that identifies the key issues to be addressed in the ESIA study. Scoping involves defining the impact topics that should be addressed in the assessment as well as those of little or no relevance to the project. Scoping is the stage at which consultations with stakeholders are initiated, which is an important part of the ESIA process.

The following topics are important in undertaking the scoping and assessment study:

**Project's Area of Influence (AoI) Identification:** The AoI was defined as follows:

- The area likely to be affected by (i) the Project and the client's activities and facilities that are directly owned, operated or managed (including by contractors) and that are a component of the Project; (ii) the impacts from unplanned but predictable developments caused by the Project that may occur later on or at a different location; or (iii) indirect Project impacts on biodiversity or on ecosystem services upon which Affected Communities' livelihoods are dependent. The major areas, facilities and communities potentially to be affected by the Project are listed below:
  - Licensed Area (for mining rights) covering two sub-fields of 50 km<sup>2</sup> including A Sub-Field of 14.4 km<sup>2</sup> and B Sub-Field of 35.6 km<sup>2</sup>. HEMA has the right to produce coal in levels lower than -400 m in Field A and in entire Field B.
  - Areas around three vertical mine shafts, which are located in the vicinity of Gomu Village (Tarlaagzi) (Shaft-1), Kazpınarı Village (Shaft-2) and Amasra District (Shaft-3), including aboveground developments at each shaft site (such as office buildings, personnel accommodation and social facilities).

- Port (Reclamation Area and Quay) Area covering approximately 163,000 m<sup>2</sup> and consisting of a breakwater, a quay structure, storage yards and conveyor system.
- Coal Washing Plant Areas covering approximately 8900 m<sup>2</sup> and consisting of two steam coal (8000 m<sup>2</sup>) and one shallow coal (900 m<sup>2</sup>) washing plants.
- Three Power Transmission Lines (scoped out of the project assessment).
- Waste Disposal Areas which are planned to be used during the construction and operation phases of the Project including coal washing plant waste disposal areas (i.e. Spoil dumpsites 1 and 2) and waste rock dumpsites around Shaft-1 and Shaft-2.
- Surrounding communities and facilities that are part of the social area of influence including:
  - Areas at which subsidence impacts may develop,
  - Areas at which hydrogeological impacts on groundwater resources are expected,
  - Traffic routes to be used during construction and operation phases which will be subject to increased traffic movements,
  - Tarlaagzi Fishing Port which is located 350 m southwest of the proposed HEMA port.

**Aspects of the environment:** The environmental aspects include the physical environment (e.g. geology, hydrology, hydrogeology, soils, air, noise, vibration, light), the biological environment (e.g. aquatic and terrestrial habitats and flora/fauna, protected areas), the cultural environment (e.g. archaeological sites), the socioeconomic environment (e.g. people, employment, income), and labor, health and safety of the communities and workers.

**Types of impacts:** Types of impacts resulting from the Project include the following:

- impact outcome: beneficial or adverse
- time aspect: permanent impacts (e.g. loss of land), temporary impacts (e.g. dust during construction phase) and long-term impacts (e.g. land contamination during the operation phase)
- nature of impact: direct impacts arising from the project (e.g. air pollution), indirect impacts as a consequence of other changes that occur by the project (e.g. influx of population due to workforce), and induced impacts (e.g. industrial development stimulated by the project)
- non-routine impacts (e.g. earthquakes, accidental events)
- cumulative impacts arising from further planned development of the project or any other existing/planned projects

A scoping study has been conducted as part of the ESIA study and was issued to HEMA in October 2013. The study is based on the review of the available project documentation provided by HEMA, environmental and social information collected through secondary sources and field surveys, and review of international standards. The results of the scoping study are summarized in *Chapter 4: Scope of the ESIA and Prior Investigations and Engagement Activities*.

#### **1.4.4 Baseline Data Collection**

The next step of the ESIA process is the collection of data to establish the existing baseline conditions (i.e. conditions in the absence of the proposed development), whereby the impacts of

construction and operation of the project can be assessed against. In undertaking the ESIA study, information on the current environmental and social baseline conditions was gathered using the following sources:

- technical reports prepared by HEMA and its consultants
- secondary data sources (existing published materials and documents, maps by the government agencies, research organizations and other relevant organizations)
- review of aerial photographs of the Project area and its surroundings
- field study results

Baseline studies and their results are described in the relevant chapters of the ESIA.

#### **1.4.5 Assessment of Impacts**

Assessment of likely impacts is undertaken by determining the value/sensitivity of resources/receptors that are affected, predicting the magnitude of impacts and evaluating the significance of impacts. This is followed by proposing mitigation measures for key significant impacts and assessing whether any residual impacts remain after the implementation of the mitigation measures.

Assessment of impacts was undertaken based on the results of the scoping study. The assessment evaluates environmental and social changes as a result of the project from the established baseline. The assessment reviews all of the possible impacts and determines which impacts are likely to be significant.

The impact magnitude depends on the degree and extent to which the project changes the environment and usually varies according to the project phase. There are various factors to be considered in determining the magnitude of impact, including but not limited to the following:

- area of influence
- deviation from existing baseline conditions
- sensitivity and importance of the receptors and resources
- nature, scale, extent, frequency and duration of the change
- duration and timing of the project

The impact magnitude is quantified on the basis of the factors listed above to the extent practicable. Depending on the nature of impact, the impact magnitude is predicted by mathematical models (e.g. noise, air quality) and by professional judgment for those impacts that cannot be represented by mathematical models (e.g. impacts on ecology). The criteria to determine the impact magnitude for physical, biological, and social environments are described in Table 1-1 below. When determining the impact magnitude, conservative assumptions are often used to ensure that impacts are not underestimated.

Table 1-1: Criteria used to determine the impact magnitude

<b>Magnitude</b>	<b>Description</b>
<b>Physical Environment</b>	
Negligible	Impacts that lead to imperceptible changes in baseline conditions
Small	Temporary or short term impacts that are localized to the immediate project area that physical environment will return to its original conditions once the impact ceases

Magnitude	Description
Medium	Temporary or short term impacts that go slightly beyond the limits of the project area and/or that are above the defined regulatory limit values, however long term integrity of any resource/receptor/process is not threatened
Large	Impacts that result in an order of magnitude change on physical environment in a wider scale, that exceed the defined regulatory limit values and irreversible
<b>Biological Environment</b>	
Negligible	Impacts that lead to imperceptible changes in baseline conditions
Small	Temporary impacts on a number of species that are common in the area and does not affect overall population, localized habitat loss
Medium	Impacts resulting in changes in the population of the species that are common in the area, long term integrity of the population is not threatened
Large	Impacts on legally protected and rare/threatened/endangered species and there is no possibility of recovery
<b>Socio-economic Environment</b>	
Negligible	Impacts that are imperceptible to communities or socio-economic values
Small	Temporary impacts that are reversible and do not affect communities or socio-economic values
Medium	Impacts to communities or socio-economic values that bring change in status but do not threaten overall stability of communities or assets
Large	Impacts to communities or socio-economic values that bring long term change in status

Criteria related to the value/sensitivity of the resources/receptors are described in Table 1-2.

Table 1-2: Criteria related to value/sensitivity of the resources/receptors

Value or sensitivity of the affected resource or receptor	Description
<b>Physical Environment</b>	
Negligible	Physical resources/receptors that are resistant to change
Low	Physical resources/receptors that can return to its original conditions after the impacts and that are not important to the wider physical environment
Medium	Physical resources/receptors that are important in the region and can return to original conditions naturally over time after the impacts
High	Physical resources/receptors that cannot return to their original conditions after the impacts
<b>Biological Environment</b>	
Negligible	Biological environment component that has no or very limited importance
Low	Biological environment component that is common to the area and not under protection
Medium	Biological environment component that is common and experiencing decline and not under protection
High	Biological environment component that is protected by national regulations and international standards and listed as rare, threatened or endangered
<b>Socio-economic Environment</b>	
Negligible	Assets are not significant regarding their resource, economic, cultural and social value
Low	Assets are not significant regarding their resource, economic, cultural and social value, and there are nearby alternatives to the affected assets
Medium	Assets are not significant in the overall project area but have local significant roles (asset base, livelihoods)



Value or sensitivity of the affected resource or receptor	Description
High	Assets are protected by national and international legislation

The significance of those impacts is decided upon once the impact magnitude and the value/sensitivity of the resource/receptor are determined. The impact significance is the product of (i) the value, importance or sensitivity of the resource or the system that might be impacted, and (ii) the magnitude of impact on that resource and system.

The impact significance has been assessed by taking into account the following:

- legislation, policies, guidelines and standards
- area of influence
- amount of resource affected
- persistence of impacts
- status of resources
- sensitivity of resources, regulatory status
- societal value

The evaluation of significance is illustrated in Table 1-3.

Table 1-3: Evaluation of significance

Value or sensitivity of the affected resource or receptor	Magnitude of impact			
	Negligible	Small	Medium	Large
Negligible	Not significant	Not significant	Not significant	Minor
Low	Not significant	Not significant	Minor	Moderate
Medium	Not significant	Minor	Moderate	Major
High	Minor	Moderate	Major	Major

For the purposes of this assessment, impacts have been categorized as follows:

- Not significant: Impact does not require any control.
- Minor Impact: Impact can be controlled using good practice management measures.
- Moderate Impact: Impact can be reduced to a reasonable level (as low as reasonably practicable) by applying feasible and cost effective mitigation measures.
- Major Impact: This is an impact for which no further mitigation is possible and there is a requirement to provide compensation or offset measures.

Significance criteria for each type of impact are presented in the relevant chapters of this report, as needed. Impacts have been assessed for key phases of the Project from initial site preparation and advance works, through construction to operation of the mine. Decommissioning of the Project is not assessed as the mining facilities are envisaged to remain in place and in operation for the foreseeable future.

#### **1.4.6 Identification of Mitigation Measures**

A principal objective of the ESIA is to identify ways of reducing the impacts of development. For this reason, subsequent to the assessment of identified impacts, mitigation measures for each impact are defined in order to avoid, minimize or remedy the significant impacts. Mitigation measures also include measures to provide environmental and social benefits. The residual impacts that are likely to remain after implementation of mitigation measures are then assessed based on the same criteria mentioned in Section 1.4.5.

Mitigation can be carried out by changes in the design, engineering modifications, and adoption of measures to address the specific impacts. During the ESIA, mitigation measures have been identified based on the Turkish regulatory requirements, IFC requirements and international best practice. The identified measures are discussed and agreed with HEMA and are presented in the ESMP provided in Annex D. Implementation of the measures identified in the ESMP will be monitored by HEMA during the construction and operation phases of the Project in order to ensure the effectiveness of these measures.

#### **1.4.7 Uncertainties**

This ESIA is prepared based on the Project information received from HEMA and a description of the Project is made in *Chapter 2* according to this information. The description of the Project is based on the information and conceptual design documents made available to ELC. The detailed design of the Project is currently ongoing. Detailed studies are still to be completed related to the design of the components of the Project such as coal washing plants and port. However, significant changes in the design of the Project are not expected to occur. Project components and other above-mentioned units will be located within the identified Project area and have been considered during the scope of impact assessment. It is not expected therefore that the present uncertainties will have a considerable effect on the identified impacts of the Project. On the other hand, in order to address the uncertainties, monitoring will be undertaken by HEMA to understand whether the identified mitigation measures are sufficient or there is a need for refinement of any mitigation measure(s).

#### **1.4.8 Environmental and Social Management Plan (ESMP)**

The ESMP is a significant part of an ESIA in which all the identified mitigation measures are outlined for the adverse impacts for each phase of the project. An ESMP has been developed as part of the ESIA study, which includes description of the mitigation measures, responsible parties for the implementation of the mitigation measures, the timing, monitoring and audit requirements. The ESMP focuses on the avoidance of impacts, and where this is not possible, presents technically and financially feasible and cost-effective mitigation measures to minimize or reduce possible impacts to acceptable levels. The ESMP of the Project is presented in Annex D of this report. The ESMP will be kept up to date with any required additional mitigation throughout the Project.

Implementation of the ESMP will be accomplished by conducting a project specific Environmental and Social Management System (ESMS) during the construction and operation phases of the Project, which will be developed by HEMA in accordance with the requirements of international standards (i.e. for quality: ISO 9001, for environment: ISO 14001 and for occupational health and

safety: OHSAS 18001). Brief information on the environmental and social management is presented in *Chapter 19: Environmental and Social Management*.

#### **1.4.9 Stakeholder Engagement**

The stakeholder engagement is an integral and crucial part of an ESIA process, aiming to provide an opportunity to affected and/or interested individuals, groups and organizations to express their views and concerns about the project, which are taken into account during the assessment of impacts and identification of mitigation measures. According to international best practice, stakeholder engagement is recommended to start with the scoping phase and to continue throughout the ESIA process. IFC Performance Standard 1 describes stakeholder engagement as an on-going process during the life of project involving the disclosure of information.

A stand-alone Stakeholder Engagement Plan (SEP) has been developed for the Project to help to structure a systematic communication with the stakeholders during the ESIA study. Also, a Project specific website has been established where the Project Information Document, Project Information Leaflet and comment forms are made available to the public (<http://XXXX>). A number of stakeholder engagements have been undertaken in the past. That have been used to assess stakeholder views on project components. These have been presented in detail in Annex M.

### **1.5 Outline of the ESIA Report**

The remaining chapters of the ESIA report are as follows:

- Chapter 2: Project Description
- Chapter 3: Institutional and Regulatory Framework
- Chapter 4: Scope of the ESIA, Prior Investigations and Engagement Activities
- Chapter 5: Land Use and Zoning
- Chapter 6: Geology, Soils and Contaminated Land
- Chapter 7: Hydrology and Hydrogeology
- Chapter 8: Material Resources and Waste Management
- Chapter 9: Marine Environment
- Chapter 10: Air Quality
- Chapter 11: Noise
- Chapter 12: Road Transportation
- Chapter 13: Ecology (Terrestrial and Marine)
- Chapter 14: Socio-economy
- Chapter 15: Community Health and Safety
- Chapter 16: Labor and Working Conditions
- Chapter 17: Cultural Heritage
- Chapter 18: Environmental and Social Management

The ESIA report is supported by the following annexes:

- Annex A: Official Correspondence/Opinion Letters related to Turkish EIA Requirements
- Annex B: Amasra Hard Coal Production Project Report by SRK, October 2013
- Annex C: Environmental, Health and Safety and Social (EHSS) Legislation Review
- Annex D: Environmental and Social Management Plan (ESMP)
- Annex E: Land Use and Zoning Supporting Information
- Annex F: Geology, Soils and Contaminated Land Supporting Information

- 
- Annex G: Hydrology and Hydrogeology Supporting Information
  - Annex H: Waste Management Plan
  - Annex I: Air Quality Modelling Report
  - Annex J: Noise Modelling Report
  - Annex K: Traffic Study
  - Annex L: Flora and Fauna List
  - Annex M: HEMA Hard Coal Mine Stakeholder Communications Plan
  - Annex N: Labor and Working Conditions Supporting Information
  - Annex O: Cultural Heritage Site Assessment Report

## 2.0 PROJECT DESCRIPTION

### 2.1 Project Overview

#### 2.1.1 Project Background

Hattat Enerji ve Maden Ticaret A.S. (HEMA), a subsidiary of Hattat Holding has been awarded the mining rights of the "Amasra Hard Coal Mine Field B" located within the borders of Amasra District of Bartın Province in the West Blacksea Region of Turkey (see Figure 2-1). In this regard, the operational rights of Amasra B Field were transferred to HEMA for a period of 20 years<sup>1</sup>, pursuant to the royalty agreement made on April 15, 2005 between the Turkish Hard Coal Enterprise (TTK) and HEMA.

The information about the Project presented in this chapter is based on the following sources:

1. Amasra Hard Coal Production Project Report by SRK (October 2013),
2. Environmental Impact Assessment Report for HEMA Port (Reclamation Area and Quay) prepared by Dokay-ÇED Ltd. (April 2013),
3. Project Introduction File for HEMA Coal Washing Plant prepared by Dokay-ÇED Ltd. (January 2014).
4. Information obtained from HEMA including correspondence with technical staff, written correspondence with relevant governmental authorities, and site visits.

The hard coal mine field in Amasra is divided into two sub-fields, i.e. Field-A and Field-B (see Figure 2-1). TTK currently produces coal in Field-A above an elevation of -400 m (the yellow zone in Figure 2-2) while HEMA has the right to produce coal in entire Field B (the green zone in Figure 2-2), which encloses the part of Field-A below -400 m. The Project site (50 km<sup>2</sup>) encloses levels lower than -400 m in Field-A (14.4 km<sup>2</sup>) and the entire Field-B (35.6 km<sup>2</sup>).

Site delivery of the mining license area was realized in May 2006. The first phase of construction has been finalized, which comprised of sinking operations of 3 vertical shafts located in the vicinity of Gömü Village (Tarlaağzı) (Shaft-1), Kazpınarı Village (Shaft-2) and Amasra District (Shaft-3)<sup>2</sup>, each with a diameter of about 8 m and depths of 700.5, 730.0 and 579.8 m respectively. The first phase of the construction was completed with the cooperation of HEMA and DATONG Coal Mine Group (DATONG) of China. In the second phase, galleries have been currently opening to connect the shafts underground and these works are undertaken by DATONG.

<sup>1</sup> This contract duration can be extended for additional 10 year-periods upon request by HEMA.

<sup>2</sup> Shaft-3 is located next to the existing TTK shaft area. Shaft-3 location is rented from TTK which was formerly used for TTK warehouse and maintenance facilities before opening of the shaft.

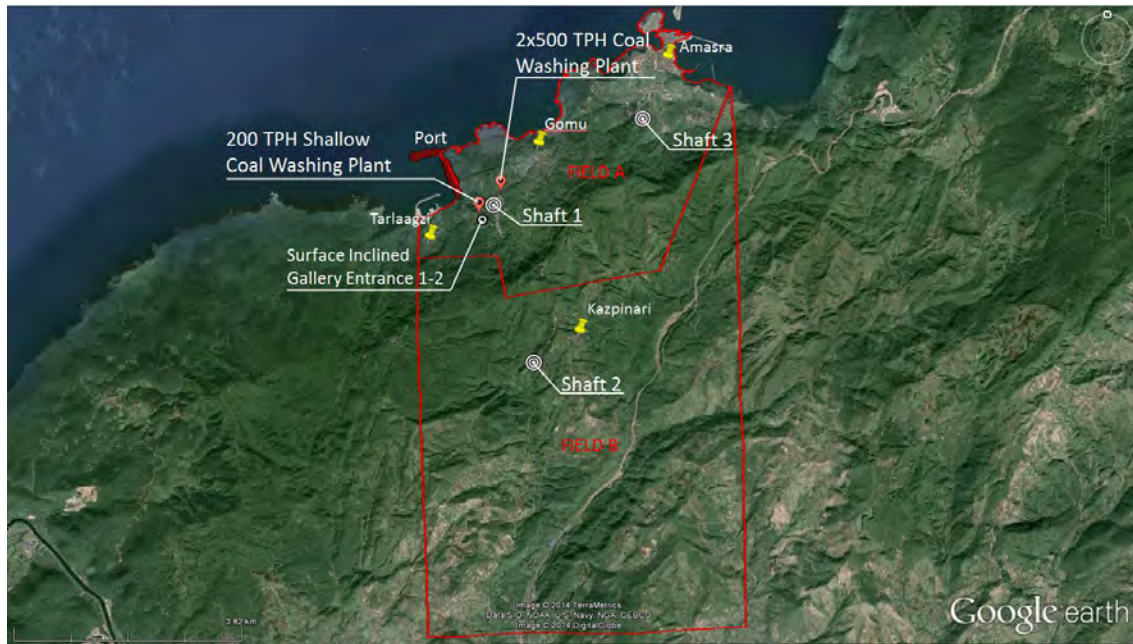

Figure 2-1: Project site map



Figure 2-2: Profile of the Project site



Photo 1. Main Project Site and Shaft-1 View

The past and planned future developments of the Project are given as follows:

- In late 2013, works for mining of shallow coals was started from surface inclined gallery tunnels located near Shaft-1. The inclined tunnel is an additional method of extraction in addition of the three vertical shafts. The extracted coal (up to 800 tons/day) will be transported to Bartın Cement Plant by roadway. This shallow coal mining component of the Project is described in Section 2.3.6.2.
- Coal extraction from the production panels is proposed to be initiated near the end of 2015. The processed coal is planned to be shipped to Çatalağzı Thermal Plant and Eren Thermal Plant in Zonguldak; and continued to be transported via roads to the Bartın Cement Plant. Fully-mechanized retreat longwall mining method will be applied for production. Annual production targeted at 5.7 million tonnes. Production of East Block will be transported underground with belt conveyors and coal will be extracted from Shaft-1. Production of West Block (including shallow coal) and Southeast Block will be transported underground with belt conveyors and coal will be extracted from the surface inclined gallery entrance. Coal mining operations (including description of the East and West Blocks) is detailed in Section 2.3.
- Coal hauled to surface will be processed in two coal washing plants to be installed in order to increase the calorific value of coal. A coal washing plant with 2x500 tonnes/h (TPH) capacity will be located near Shaft-1, and another coal washing plant with 200 TPH capacity will be located near the surface inclined gallery entrance. Coal washed will be temporarily stored at the stock yards located next to the coal washing plants. The coal washing plants are discussed in Section 2.4.
- Transportation of processed coal to the above mentioned thermal plants requires sea-shipment. In this regard, the HEMA port (reclamation area and quay) project has been planned to be constructed east of the existing Tarlaağzı Fishing Port in the coastal part of Tarlaagzi Village ; the Port is intended to become operational by mid-2017. Consequently part of the end product will be conveyed from Shaft-1 site to the bulk cargo quay via a covered belt conveyor system, in order to be shipped to the thermal plants in Zonguldak. The Port project is described in Section 2.5.
- Reclamation material required for the port construction will be obtained from the slope protection area located behind the quay structure. This area will be sloped for the purpose of stabilization against risks such as landslides. Details regarding the slope protection area are given in Section 2.5.3.8.
- Additionally, there will be three power transmission lines within the scope of the Project. At present, there is a existing 31.5 kV power transmission line erected. Two more power lines of 31.5 kV and 154 kV will be erected to supply additional electrical power for project activities. Further information regarding the power lines is provided in section 2.6.

### **2.1.2 Background of HEMA in Coal Mining**

HEMA has a long history in coal mining. It has started producing mining tools and machinery for the government in the 1970's.

HEMA has been operating another coal mine field, namely Kandilli Hard Coal Mine Field, in Kandilli/Zonguldak region, which is another remarkable spot with high amount of coal reserves. Kandilli Hard Coal Mine Field occupies a surface area of 28.44 km<sup>2</sup> and coal production and marketing activities have been ongoing since mid-2006.

Operations of Amasra and Kandilli mine fields are technically quite different. In Kandilli Mine, conventional mining method is being used for coal extraction whereas in Amasra Mine, fully mechanized retreat longwall mining method will be used. Nevertheless, the two operations have a common upper management.

### **2.1.3 Need for the Project**

Currently there is a considerable amount of energy deficit in Turkey. Considering the ever growing energy demand, the HEMA project will contribute to the country's economy by harvesting of the hard coal reserves in Amasra B field efficiently, effectively, timely and in an environmentally responsible manner.

Hard coal is widely utilized in diverse industries. Iron-steel factories need hard coal of coking coal (mainly used in steel production) quality, whereas thermal power plants need it as steam coal (mainly used in power generation) (World Coal Institute, Coal-Steel Report<sup>1</sup>, 2009). In addition to iron-steel factories and thermal plants, other industries, such as cement and similar industry branches, also consume hard coal to meet their primary energy needs. Hard coal is crucial especially in iron-steel factories since it does not have a substitute.

The only hard coal reserves in Turkey are in Zonguldak and Bartın/Amasra Basins. According to TTK's Hardcoal Sector Report for 2012<sup>2</sup>, dated May 2013, total volume of geological hard coal reserves in Turkey is about 1.31 billion tonnes, where 67% of total reserves is in coking quality, 2% is in half coking quality and the remaining 31% is not in coking quality.

Hard coal consumption in Turkey is heavily dependent on imported coal. According to above-mentioned report, hard coal consumption in Turkey increased from 25.6 million tonnes to 26.2 million tonnes between 2010 and 2011 and domestic production decreased from 2.6 million tonnes to 2.3 million tonnes between 2011 and 2012, respectively. In addition, since early 2000s, both consumption and production of hard coal have increased as per TTK's Hard Coal Activity Report dated April 2011 (Table 2-1).

---

<sup>1</sup> <http://www.worldcoal.org/search-results/index.php>

<sup>2</sup> [http://www.enerji.gov.tr/yayinlar\\_raporlar/Sektor\\_Raporu\\_TTK\\_2012.pdf](http://www.enerji.gov.tr/yayinlar_raporlar/Sektor_Raporu_TTK_2012.pdf)



Table 2-1: Hard coal production and consumption data in Turkey (million tonnes)

	2000	2001	2002	2003	2004	2005	2006	2007	2008	2009	2010
<b>Production</b>	2,394	2,493	2,319	2,059	1,945	2,177	2,318	2,492	2,630	2,879	2,592
<b>Consumption</b>	15,393	11,039	13,830	17,535	18,904	19,421	22,798	25,224	22,720	23,698	N/A
<b>Production/ Consumption</b>	15.5%	22.5%	16.7%	11.6%	10.3%	11.2%	10.2%	9.9%	11.6%	12.2%	N/A

Source: <http://www.taskomuru.gov.tr/file/2011.pdf> (TTK, Hard Coal Activity Report, April 2011)

During 1980s, the ratio of domestic hard coal production to domestic consumption was calculated as 80% and declined to approximately 10% during second half of 2000s. As a result, import has been made from countries such as Russia, South Africa, Australia, USA, China and Canada. It is projected that the need for imported hard coal will persist due to the high levels of local consumption (TTK's Hardcoal Sector Report for 2012, May 2013). Given the growing need for hard coal production and the crucial role of hard coal in various industries, the proposed Project aims to contribute to the security of coal supply and decrease the dependency of Turkey to imported hard coal.

## 2.2 Evaluation of Project Alternatives

### 2.2.1 Site Alternatives

Since a hard coal mine project can only be realized in an area where the hard coal reserve (i.e. extractable part of the resource) is present and HEMA has an operation license in the subject Project site, there are no site alternatives for the Project.

### 2.2.2 Technology Alternatives

In underground mining, one of three methods is commonly used to extract the coal: room-and-pillar, longwall, or shortwall.

*Room-and-Pillar Mining:* Room-and-pillar mining has been used longer than any other underground method. Mining is accomplished by driving entries off the panel entries. As mining advances, rooms are excavated in the coal seam; the strata above the seam are supported by pillars of coal left in place. After a block panel or section has been mined, part of the coal in the pillars can be recovered as a retreat is made toward a main entry. Since about 1950, continuous mining using electric-powered machines to bore, dig, or rip the coal from the working face has largely replaced conventional mining, which involved undercutting, drilling, placing explosives, and blasting to extract the coal. Coal is either loaded directly into shuttle cars by the machine or in a separate operation. So-called continuous mining is interrupted by stops to support the roof, await shuttle cars, advance power and water supplies, and service the equipment.

*Longwall Mining:* Longwall mining is used most efficiently in uniform coal seams of medium height. As in the room-and-pillar method, longwall mining starts with sets of entries cut into the panel areas. The difference in the technique lies in the distance between these sets of entries and the method used to extract intervening coal. The longwall machine laterally shears or plows coal from the entire face, transports the fallen coal by an advancing conveyor to a secondary haulage conveyor,

reverses direction at the end of a cut, and supports the roof in the area of the face by a self-advancing system of hydraulic jacks. Over 80% of the entire coal face can be removed with this method. The roof is allowed to cave behind the advancing work areas; the roof is occasionally blasted to ensure a controlled cave-in rate and to reduce overburden pressure on the coalbed being mined.

*Shortwall Mining:* The shortwall method of mining coal is best described as a method similar to longwall mining with two exceptions. The blocks of panels are smaller and the coal is cut with a continuous miner and is loaded into shuttle cars.

Among the described methods, longwall mining method is chosen for the Project based on the following main reasons:

- Appropriate production system for full mechanized mining,
- Minimum production losses,
- Relatively more economical and safer for up to 700 m panel lengths and 150-200 m face lengths,
- Lower fire risk compared to room-and-pillar method,
- Presence of coal seams thicknesses below 5 m in general, making shortwall mining relatively less practicable.

Longwall mining method is described in detail in section 2.3.6.

## **2.3 Coal Mining**

### **2.3.1 Production Blocks and Reserve Characteristics**

According to the Amasra Hard Coal Production Project Report by SRK (October 2013), three production blocks that are suitable for full mechanized mining have been identified, named as East Block, West Block and Southeast Block (Figure 2-3).

A hard coal resource estimation study has been undertaken by HEMA based on the drilling works completed to date and the results are presented in the “Amasra Hardcoal Project Resource Estimation Study Report” dated October, 2013. According to this study, the measured, indicated, inferred and total resource estimations at HEMA production blocks (in terms of both gross tonnes and total tonnes in situ) are as given in Table 2-2.

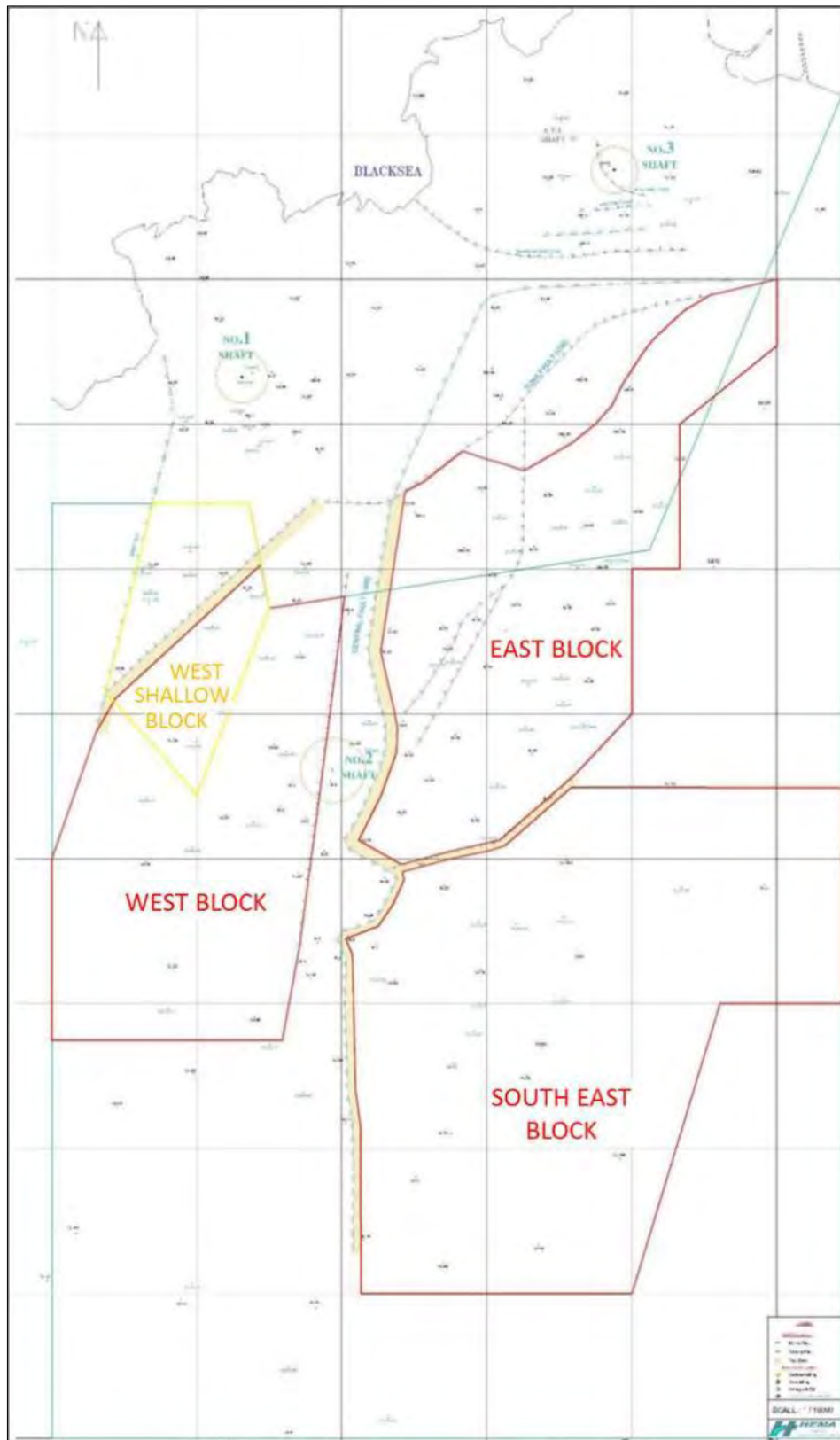

Figure 2-3: Hard Coal Mine Production Blocks

Table 2-2: Measured, indicated, inferred and total resource estimations at HEMA production blocks

Resource Type	West Block		East Block		Southeast Block		West Shallow Seams		Total	
	GTIS (Mt)	TTIS (Mt)	GTIS (Mt)	TTIS (Mt)	GTIS (Mt)	TTIS (Mt)	GTIS (Mt)	TTIS (Mt)	GTIS (Mt)	TTIS (Mt)
Measured	62.11	55.38	31.41	27.18	15.58	14.02	6.89	5.51	115.99	102.09
Indicated	19.83	17.70	17.38	15.03	18.00	16.20	1.58	1.27	56.79	50.20
Inferred	5.36	4.78	3.96	3.43	6.29	5.66	0.17	0.13	15.78	14.00
Total resource	87.30	77.86	52.75	45.64	39.87	35.88	8.64	6.91	188.56	166.29

GTIS: Gross tonnes in situ, TTIS: Total tonnes in situ

81 rotary boreholes and 53 core boreholes were previously completed by General Directorate of Mineral Research and Exploration (MTA) within the licence area. 88 additional core boreholes have been installed by HEMA in order to clarify the continuity of coal seams and tectonic structure of the field. The drilling program is still in progress. HEMA has 6 drilling rigs in the field, being used for exploration of the southern part of the license area and to provide supplementary information on previous boreholes of insufficient depth.

After core logging, lithological logs have been prepared. Meanwhile, borehole data were confirmed by geophysical logs such as Gamma-Ray, Neutron, Dipmeter and Density. Based on coal seam and thickness data, development plans have been prepared for: 6 coal seams in the East Block (EC-100, 200, 300, 400, 500, 600) and 2 coal seams in the Southeast Block (SEC-400, SEC-500) which are Westphalia-C (WC) aged and occurring in Karadon formation; 7 coal seams in Western Block (WA-100, 200, 300, 400, 500, 600, 700) which are Westphalia-A (WA) aged and occurring Kozlu formation; and 6 seams in the West Shallow Block which are WC aged (WSC-300, 400, 500, 600) and WA aged (WSA-100, 200). The characteristics of the production blocks and estimated reserve amounts are provided in Table 2-3. Furthermore, during the gallery advancements, a total of 236,706 m will be driven as gateways. Approximately, an additional 5.6 million tonnes of coal is expected to be extracted from these gateways.

Table 2-3: Characteristics of production blocks

Characteristic	West Block	East Block	Southeast Block	West Shallow Seams	
Reserve estimation (Mt)	37	45	21	3.5	
Seams No. (From top to bottom)	WA-100 WA-200 WA-300 WA-400 WA-500 WA-600 WA-700	EC-100 EC-200 EC-300 EC-400 EC-500 EC-600	SEC-400 SEC-500	WSC-300 WSC-400 WSC-500 WSC-600	WSA-100 WSA-200
Seam age	WA	WC	WC	WC	WA
Formation	Kozlu	Karadon	Karadon	Karadon	Kozlu
Reserve depth (m)	-250 to -800	-410 to -530	-680 to -890	+90 to +30	+160 to -20
Production area (km <sup>2</sup> )	3.7	4.2	4.1	1.2	

HEMA has collected 525 coal samples during the geological investigation program. Chemical properties of the Amasra coals, based on arithmetic averages of analytical results for samples collected at each coal seam are provided in Table 2-4.

Table 2-4: Chemical analysis of Amasra coals

West Block Coals								
Seam #	Test Type	Moisture (%)	Ash (%)	Volatile Matter (%)	Fixed Carbon (%)	Total Sulfur (%)	Upper Calorific Value (kcal/kg)	Lower Calorific Value (kcal/kg)
WA100	Original Basis	1.50	15.89	33.50	49.10	1.09	6809	6568
	Dry Basis	-	16.13	34.01	49.85	1.11	6912	6677
WA200	Original Basis	1.25	14.86	33.07	49.84	0.63	6850	6604
	Dry Basis	-	15.14	33.71	50.82	0.64	6983	6744
WA300	Original Basis	2.20	16.00	30.28	51.52	0.55	6714	6471
	Dry Basis	-	16.43	30.94	52.62	0.57	6859	6593
WA400	Original Basis	2.43	8.20	32.21	57.16	0.46	7502	7242
	Dry Basis	-	8.13	33.03	58.58	0.47	7690	7438
WA500	Original Basis	1.84	9.68	32.55	55.93	0.49	7492	7161
	Dry Basis	-	9.85	33.17	56.98	0.50	7556	7307
WA600	Original Basis	1.53	20.79	29.78	47.90	0.74	6498	6271
	Dry Basis	-	21.07	30.26	48.68	0.75	6553	6381
WA700	Original Basis	1.42	38.34	23.51	36.73	0.55	4731	4562
	Dry Basis	-	38.88	23.85	37.26	0.56	4800	4637
Average	Original Basis	<b>1.74</b>	<b>17.68</b>	<b>30.70</b>	<b>49.74</b>	<b>0.64</b>	<b>6657</b>	<b>6411</b>
	Dry Basis	-	<b>17.95</b>	<b>31.28</b>	<b>50.68</b>	<b>0.66</b>	<b>6765</b>	<b>6540</b>
East Block Coals								
Seam #	Test Type	Moisture (%)	Ash (%)	Volatile Matter (%)	Fixed Carbon (%)	Total Sulfur (%)	Upper Calorific Value (kcal/kg)	Lower Calorific Value (kcal/kg)
EC100	Original Basis	2.58	30.40	27.74	39.29	0.68	5102	4906
	Dry Basis	-	31.25	28.47	40.28	0.70	5236	5050
EC200	Original Basis	2.39	31.81	27.19	38.61	0.98	4970	4778
	Dry Basis	-	32.64	27.84	39.52	1.00	5087	4905
EC300	Original Basis	2.73	26.88	28.68	41.21	0.60	5433	5219
	Dry Basis	-	27.76	29.44	42.27	0.61	5574	5372
EC400	Original Basis	2.22	25.47	29.80	42.51	0.86	5569	5343
	Dry Basis	-	26.09	30.46	43.45	0.88	5684	5476
EC500	Original Basis	2.15	22.41	31.50	43.94	0.78	5857	5317
	Dry Basis	-	22.96	32.17	44.87	0.80	5979	5762
EC600	Original Basis	1.98	30.99	29.18	37.35	0.52	5152	4957
	Dry Basis	-	31.67	29.78	38.23	0.53	5252	5064
Average	Original Basis	<b>2.27</b>	<b>26.44</b>	<b>29.79</b>	<b>41.25</b>	<b>0.69</b>	<b>5503</b>	<b>5209</b>
	Dry Basis	-	<b>27.12</b>	<b>30.46</b>	<b>42.21</b>	<b>0.71</b>	<b>5622</b>	<b>5418</b>
Southeast Block Coals								
Seam #	Test Type	Moisture (%)	Ash (%)	Volatile Matter (%)	Fixed Carbon (%)	Total Sulfur (%)	Upper Calorific Value (kcal/kg)	Lower Calorific Value (kcal/kg)
SEC400	Original Basis	2.06	22.21	32.11	43.63	0.83	5932	5714
	Dry Basis	-	22.71	32.77	44.52	0.85	6053	5845
SEC500	Original Basis	2.21	25.93	29.75	42.11	0.93	5555	5344
	Dry Basis	-	26.47	30.44	43.08	0.95	5685	5482
Average	Original Basis	<b>2.13</b>	<b>24.07</b>	<b>30.93</b>	<b>42.87</b>	<b>0.88</b>	<b>5743</b>	<b>5529</b>
	Dry Basis	-	<b>24.59</b>	<b>31.61</b>	<b>43.80</b>	<b>0.90</b>	<b>5869</b>	<b>5664</b>

West Shallow Seams Coals								
Seam #	Test Type	Moisture (%)	Ash (%)	Volatile Matter (%)	Fixed Carbon (%)	Total Sulfur (%)	Upper Calorific Value (kcal/kg)	Lower Calorific Value (kcal/kg)
WSC300	Original Basis	7.65	23.39	29.63	39.32	1.39	5163	4938
	Dry Basis	-	25.27	32.11	41.62	1.39	5596	5399
WSC400	Original Basis	5.89	38.05	26.31	29.74	1.10	3869	3691
	Dry Basis	-	40.27	28.02	31.71	1.17	4126	3972
WSC500	Original Basis	6.36	25.72	31.1	36.81	1.21	5112	4889
	Dry Basis	-	27.46	33.21	39.58	1.29	5460	5260
WSC600	Original Basis	8.1	26.14	29.41	36.35	0.63	4934	4705
	Dry Basis	-	28.44	32.00	39.56	0.69	5369	5171
WSA100	Original Basis	4.51	21.26	27.97	46.4	0.44	5726	5510
	Dry Basis	-	22.21	29.25	48.53	0.46	5988	5789
WSA200	Original Basis	3.94	18.51	29.35	48.19	0.41	6070	5843
	Dry Basis	-	19.28	30.54	50.16	0.43	6318	6105
Average	Original Basis	6.08	25.51	28.96	39.47	0.86	5146	4929
	Dry Basis	-	27.16	30.86	41.86	0.91	5476	5283

### 2.3.2 Shaft Locations

Based on the targeted production, 3 shafts have been installed as part of the Project (Figure 2-4).



Figure 2-4: Aerial view of shaft locations and nearby settlements

Shaft-1 is located between Gömü and Tarlaağzı Villages, approximately 900 m southwest of Gömü Village, 1.2 km northeast of Tarlaağzı Village and 1 km east of the Tarlaağzı Fishery Port. The shaft is located at a driving distance of approximately 2.6 km to the Amasra-Bartın road. There is a village road crossing the south end of the shaft area, which connects the Amasra-Bartın road to Gömü and

Tarlaağzı Villages. The aerial view of Shaft-1 location before and after mine development activities is provided in Figure 2-5.



Figure 2-5: Aerial view of Shaft-1 location before and after mine development activities (Left: Photo dated October 2003; Right: Photo dated December 2009)

Shaft-2 is located approximately 700 m southwest of Kazpınarı Village, at driving distances of 850 m to Amasra-Bartın Road and 4.5 km to Bartın-Ankara road. The aerial view of Shaft-2 location before and after mine development activities is provided in Figure 2-6.



Figure 2-6: Aerial view of Shaft-2 location before and after mine development activities (Left: Photo dated October 2003; Right: Photo dated December 2009)

Shaft-3 is located approximately 800 m south of Amasra Center. It is located at a distance of 500 m to the new road which is under construction (discussed in section 2.6.1.2) and there are mining facilities belonging to TTK around the shaft. The aerial view of Shaft-3 location before and after mine development activities is provided in Figure 2-7.



Figure 2-7: Aerial view of Shaft-3 location before and after mine development activities (Left: Photo dated October 2003; Right: Photo dated December 2009)

### 2.3.3 Project Planning

The phases of the mining Project are; opening of the shafts, gallery driving, other preparatory works and the production phase.

As noted above, installation of the mine shafts of the Project has been completed. In addition, West Block surface mining works have been started throughout the inclined Surface gallery near Shaft-1. For electricity demand of the Project activities, 31.5 kV electrical substations have already been established at shafts.

Coal extraction from the shafts is proposed to be initiated at the end of 2015. In the East Block, production will start in late 2015, while in the West Block, production will start in 2017. The production in Southeast Block will begin in 2028. Projections of annual production levels at West, East and Southeast Production Blocks and at the block gateways are presented in Figure 2-8. Projections of annual production levels of shallow coals are presented in Figure 2-9.

The main works to be performed until the mine starts production are as follows:

- Underground development works
- Aboveground construction works
- Electrical works
- Purchasing of equipment
- Installation works
- Installation of coal washing plants
- Installation of methane drainage systems
- Other necessary construction works

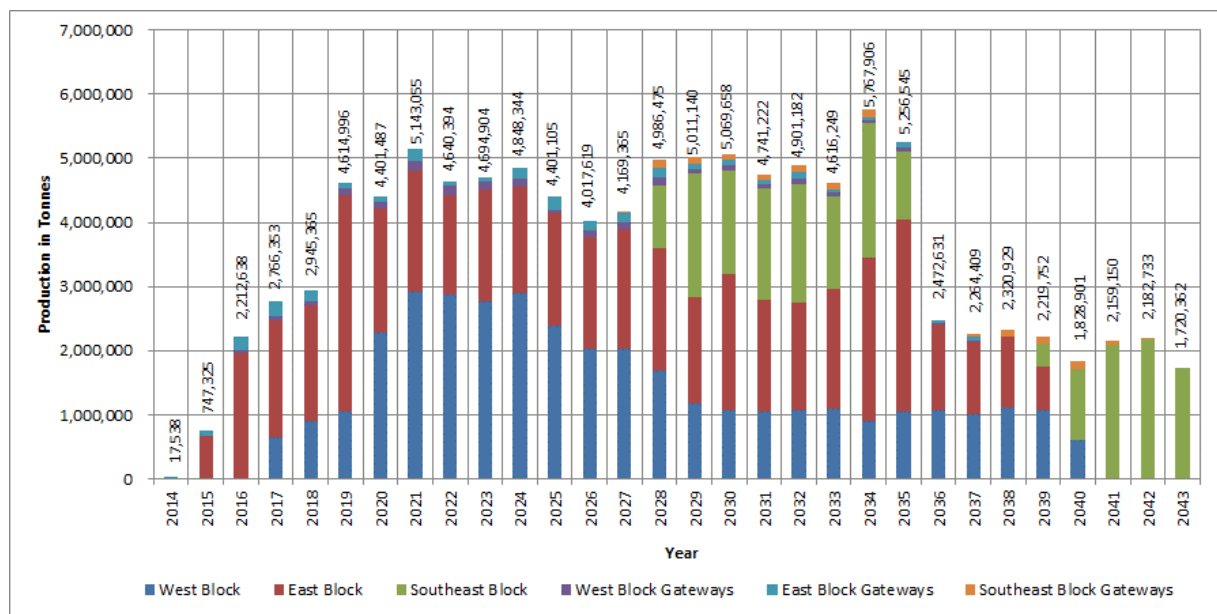

Figure 2-8: Graph showing overall production by years at West, East and Southeast Production Blocks



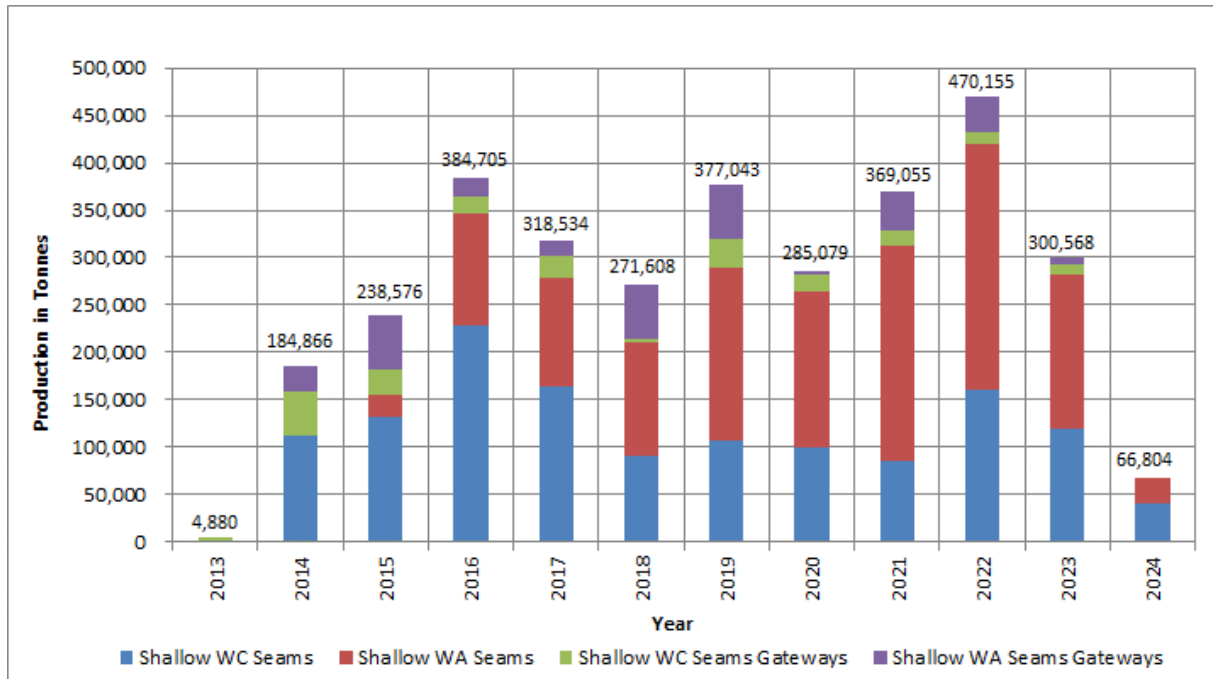

Figure 2-9: Graph showing overall production of shallow coals by years

### 2.3.4 Major Aboveground Developments

Several aboveground facilities for coal production at the shaft sites have already been constructed. Existing facilities and structures include headframes at Shaft-1 and Shaft-2, skip and cage winder houses at Shaft-1, final winder house at Shaft-2, fuel station at Shaft-1, magazine (dynamite warehouse) at Shaft-1, tippler stations, concrete stations, boiler houses, water storage tanks, cooling tanks, 31.5 kV electrical substations, transformers, power lines, maintenance workshops, warehouse, personnel accommodation and social facilities, cabins and showers, temporary office building, training buildings, laboratory and security building. Photographs of selected facilities are given below in Photo 2 through Photo 9.

Facilities under construction and to be constructed at the site include the following:

- Headframe (Shaft-3)
- Final winder house (Shaft-3)
- Boiler house (Shaft-1)
- Coal washing plants (Shaft-1)
- Administrative buildings
- Fire fighting facilities
- Drinking and fire fighting water storage (volume 300 m<sup>3</sup>)
- Raw coal silos (four units, each with a volume of 1100 m<sup>3</sup>) and clean coal silos (four units, each with a volume of 1100 m<sup>3</sup>)
- Belt conveyor to the port
- Coal loading platform for trucks
- Discard belt conveyor

- Aggregate silos (Shaft-1)
- Power transmission lines, 154/33 kV transformer and substation 2\*25 MVA
- Rescue station (Shaft-1)
- Domestic wastewater treatment plants (Shaft-1, Shaft-2)
- Water treatment plant (Shaft-1, Shaft-2)
- Industrial wastewater treatment plant (i.e. serial settlement tanks) (Shaft-1)
- Water line (from Shaft-2 to Shaft-1 and port)
- Temporary waste storage area
- Ventilation gallery and fan building (Shaft-3 and shallow coal mine)
- Gas recovery stations (Shaft-3 and shallow coal mine)

The general construction schedule for the aboveground structures is provided in Table 2-5. The general layout at the three shaft locations are provided in Figure 2-10 through Figure 2-12.



Photo 2. General view of the Shaft-1 site



Photo 3. Magazine (explosive warehouse)



Photo 4. Personnel accommodation facilities



Photo 5. Warehouses near Shaft-1



Photo 6. Surface inclined gallery entrance



Photo 7. Surface inclined gallery



Photo 8. Shaft-2 site



Photo 9. Shaft-3 site

Table 2-5: Tentative construction program for aboveground facilities for coal mining

Component	Location	2011	2012	2013	2014	2015	2016	2017
Headframe	Shaft-1							
	Shaft-2							
	Shaft-3							
Coal washing plant 500 TPH capacity	Shaft-1							
Coal washing plant 500 TPH capacity	Shaft-1							
Administrative buildings	Shaft-1							
	Shaft-2							
	Shaft-3							
Boiler house	Shaft-1							
	Shaft-2							
	Shaft-3							
Electrical switch room	Shaft-1							
	Shaft-2							
	Shaft-3							
Compressor house	Shaft-1							
	Shaft-2							
	Shaft-3							
Water storage (Potable water)	Shaft-1							
	Shaft-2							
	Shaft-3							
Clean coal silo	Shaft-1							
Raw coal silo	Shaft-1							
Skip winder house start-up	Shaft-1							
Cage winder house start-up	Shaft-1							
Final winder house	Shaft-1							
	Shaft-2							
	Shaft-3							
Underground wastewater treatment plant	Shaft-1							
	Shaft-2							
	Shaft-3							
Belt conveyor to the port	Shaft-1							
Magazine (dynamite warehouse)	Shaft-1							
Workshops	Shaft-1							
	Shaft-2							
	Shaft-3							
Electrical workshops	Shaft-1							
	Shaft-2							
	Shaft-3							
Discard belt conveyor	Shaft-1							
Aggregate silos	Shaft-1							
Rescue station	Shaft-1							
Domestic water treatment plant	Shaft-1							
	Shaft-2							
	Shaft-3							
Personnel accommodation and social facilities	Shaft-1							
	Shaft-2							
	Shaft-3							
Power line	Shaft-1							
	Shaft-2							
	Shaft-3							
Signal room	Shaft-1							
	Shaft-2							
	Shaft-3							
Generator	Shaft-1							
	Shaft-2							
	Shaft-3							
Gas recovery station	Shaft-1							
Power building	Shaft-1							
	Shaft-2							
	Shaft-3							
Cooling tanks	Shaft-1							
	Shaft-2							
	Shaft-3							
Fuel station	Shaft-1							
31.5 kV Substation	Shaft-1							
Transformer 400 Kva	Shaft-1							
154/33 kv transformer and substation	Shaft-2							
Transformer and substation 31.5 kV	Shaft-3							
Auxiliary facilities	Shaft-1							
	Shaft-2							
	Shaft-3							
Concrete stations	Shaft-1							
	Shaft-2							
	Shaft-3							
Fire-fighting facility	Shaft-1							
	Shaft-2							
	Shaft-3							
Tippler	Shaft-1							
	Shaft-2							
	Shaft-3							
Training administrative buildings	Shaft-1							
Training building	Shaft-1							
	Shaft-2							
	Shaft-3							
Warehouse	Shaft-1							
	Shaft-2							
	Shaft-3							
Railway	Shaft-2							
Ventilation gallery	Shaft-3							
Ventilation fan building	Shaft-3							
Laboratory	Shaft-3							
Cabins and showers	Shaft-3							
Coal Washing plants 200 TPH capacity	Shaft-1							
Truck loading facility	Shaft-1							
Store room	Shaft-3							

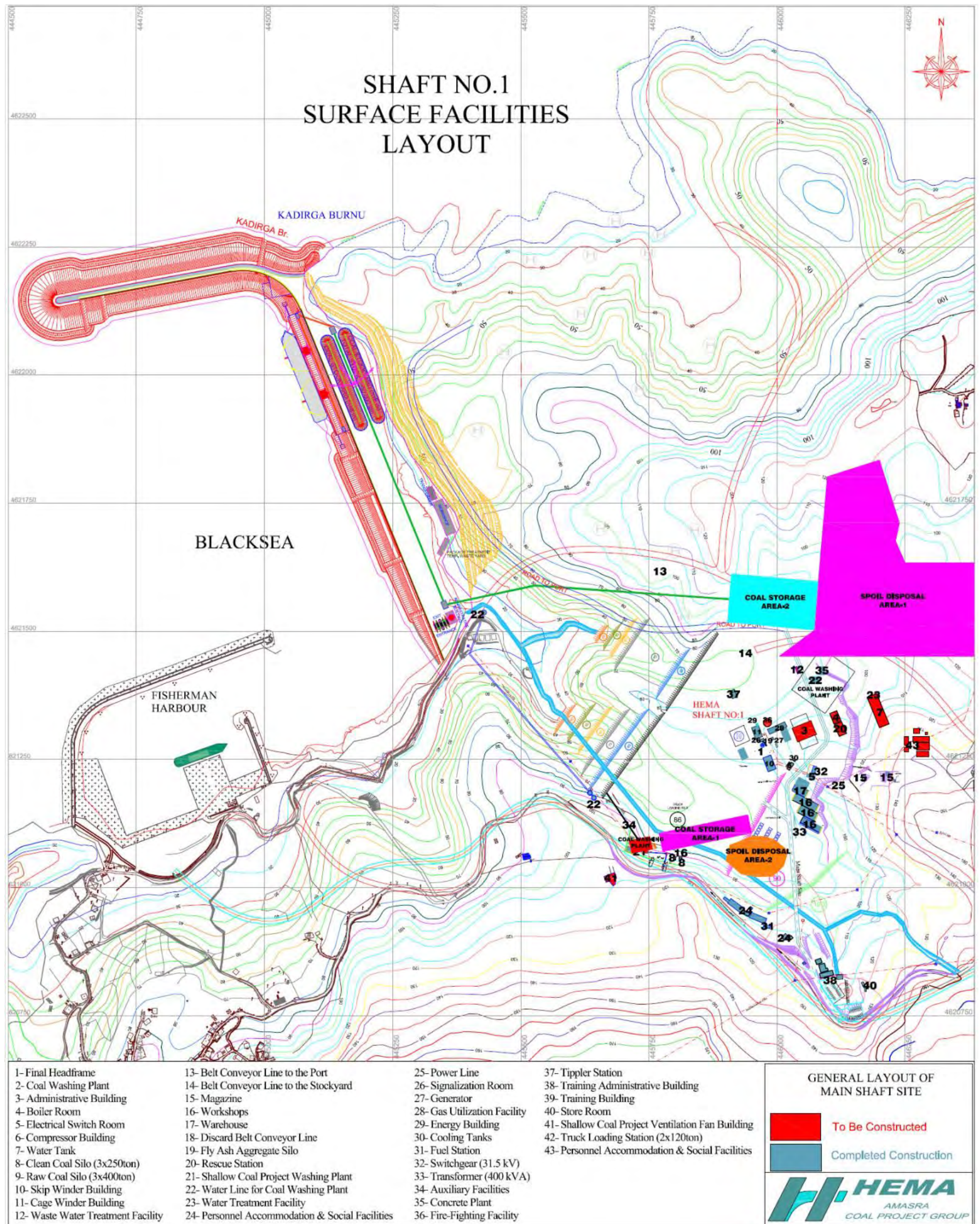

Figure 2-10: Shaft-1 general layout

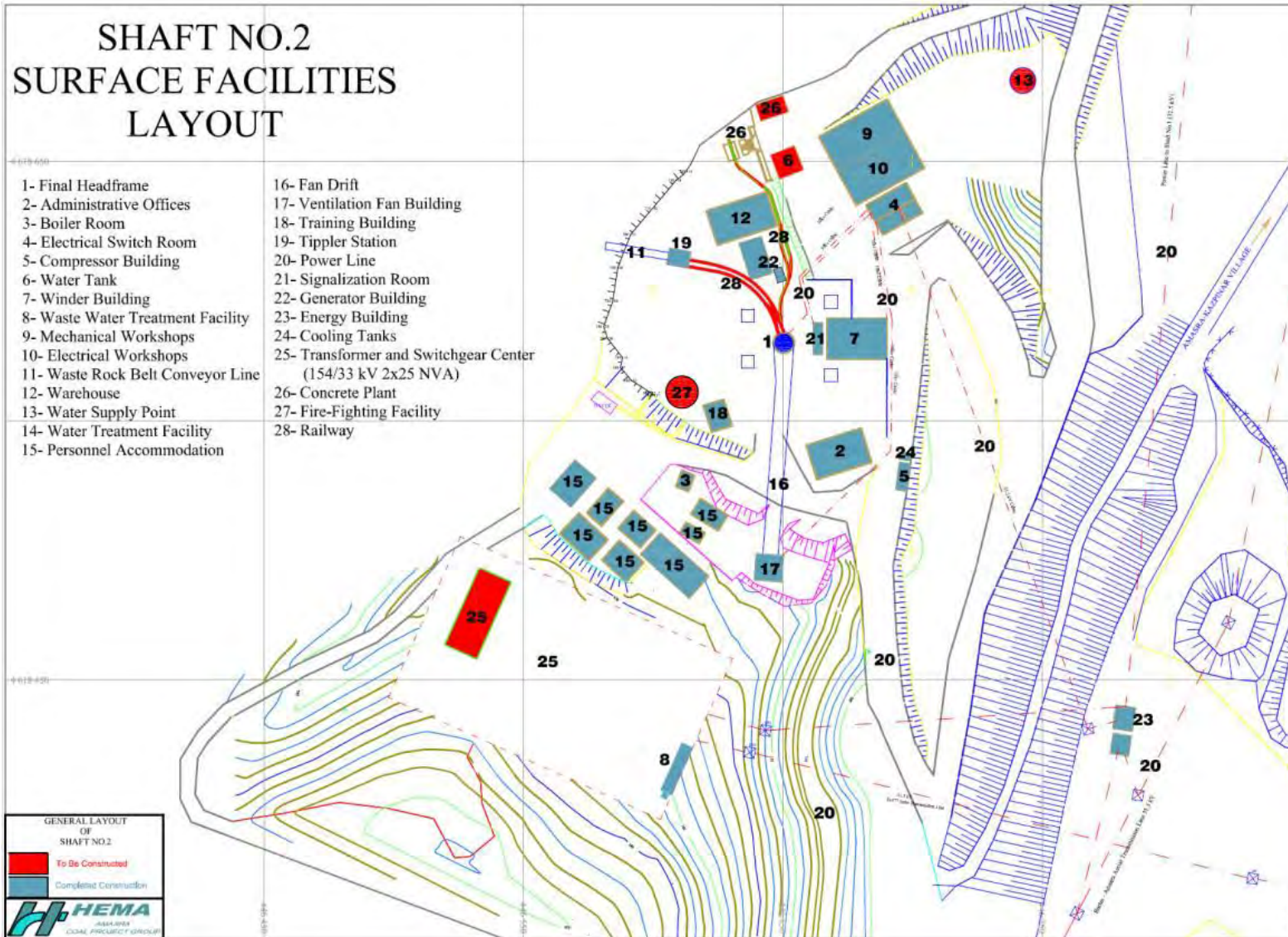

Figure 2-11: Shaft-2 general layout

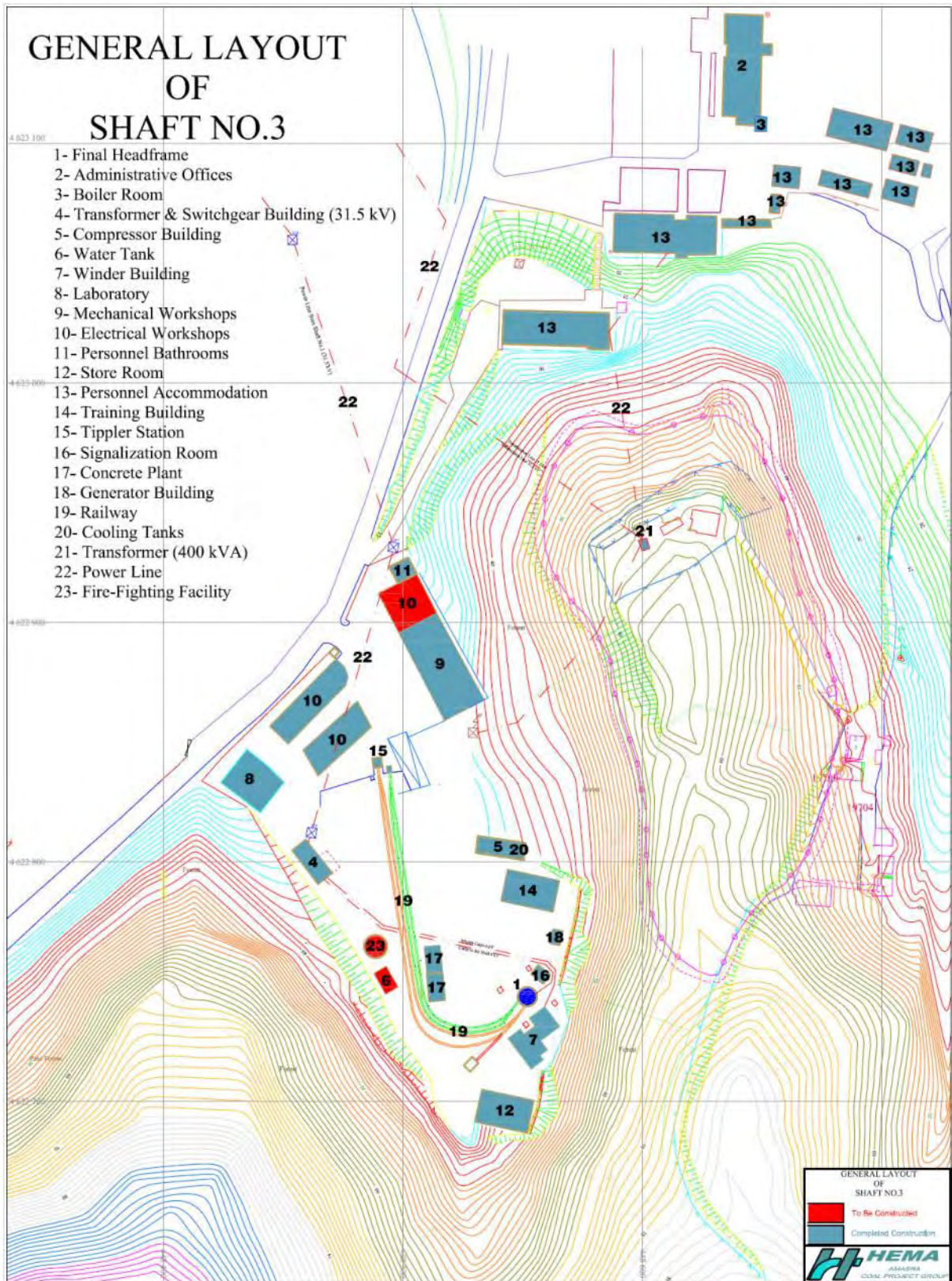

Figure 2-12: Shaft-3 general layout

### 2.3.5 Major Underground Developments

#### 2.1.1.1 Hoist Shafts

Based on the targeted production, three shafts of 8 m diameter each have been installed as part of the mining Project. Shaft-1 has 700 m, Shaft-2 has 730 m and Shaft-3 has 580 m depth. Minimum concrete thickness in shafts is 50 cm. Excavation and concrete volumes for each shaft are listed in Table 2-6 below.

Table 2-6: Excavation-concrete comparison at shafts

Parameter	Shaft-1	Shaft-2	Shaft-3
Total excavation volume (m <sup>3</sup> )	39718	46526	32852
Total concrete volume (m <sup>3</sup> )	8795	10303	7275

Hoist shaft locations are selected such that they lie outside the production panel zones. Production zones are isolated by big faults. As shown in Figure 2-3, the Amasra field is divided into two blocks (East and West) by the Central Fault. East Block boundary is Fault No.2 in South and Tuna Fault in North. West Block boundary is Fault No.3 in North and sterile zone in South. Southeast Block boundary is Fault No.2 in North and sterile zone in South. Shafts and galleries will serve these blocks.

Hoisting of East Block coal is planned from Shaft-1 with a double-skip system, while surface inclined galleries will be used to extract the coal of West and Southeast Blocks. Hoisting of materials and personnel is planned from Shaft-1, 2 and 3 with cage systems. -410 and -510 are designed as main operation levels and accordingly, double sided -410 and - 510 insets have been constructed in shafts. The functions and basic technical characteristics of the three shafts are summarized in Table 2-7 below and their longitudinal sectional drawings are given in Figure 2-13.

Table 2-7: Technical characteristics of installed shafts

	SHAFT -1 (Gömü-Tarlağzı)	SHAFT -2 (Kazpınarı)	SHAFT-3 (Amasra)
Purpose	Skip (production) and hoisting shaft	Skip and hoisting shaft	Ventilation and hoisting shaft
Function	<ul style="list-style-type: none"> <li>Production of coal (by double skip system)</li> <li>Personnel and material transport (by cage system)</li> <li>Clean air inlet</li> </ul>	<ul style="list-style-type: none"> <li>Personnel and material transport (by cage system)</li> <li>Clean air intake</li> </ul>	<ul style="list-style-type: none"> <li>Personnel and material transport (by cage system)</li> <li>Clean air return</li> <li>Main ventilation shaft (Exhaust)</li> </ul>
Equipment	Single cage (5 m <sup>3</sup> ) Double skip	Single cage (5 m <sup>3</sup> ) Skip system	Single cage (5 m <sup>3</sup> )
Start date	July 17, 2007	January 31, 2008	January 1, 2008
Completion date	April 15, 2010	February 28, 2011	January 7, 2010
Diameter (m)	8	8	8
Depth (m)	700.5	730.0 (current), 820.9 (future)	579.8
Surface elevation (m)	+86.33	+180.92	+32.31
Bottom elevation (m)	-614.2	-549.1 (current), -640 (future)	-547.5
Double-sided insets (m)	-410	-410, -510 and -610 (to be constructed)	-410 and -510
One-sided insets (m)	- 250 and -325, -510	-250 and -325	-325



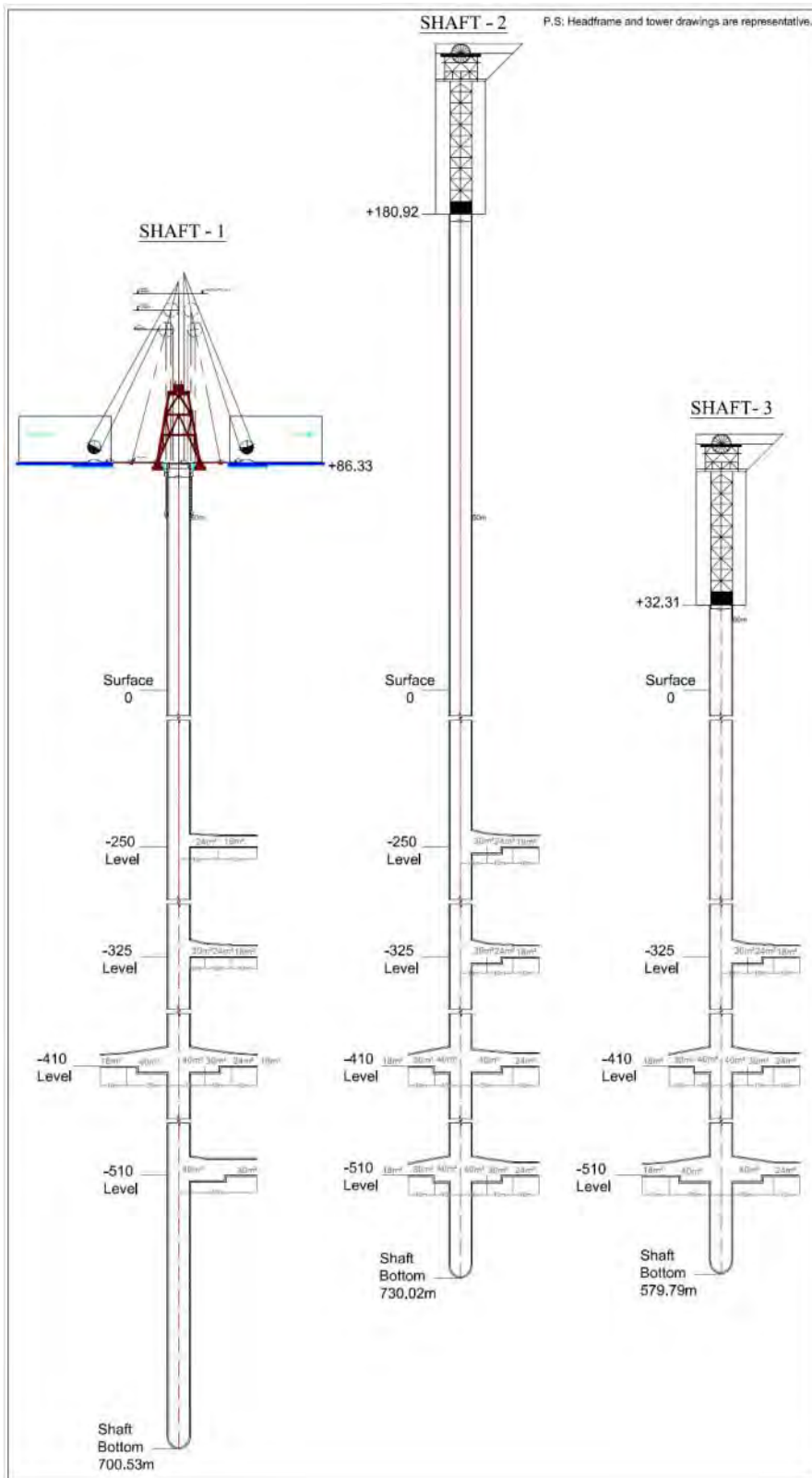

Figure 2-13: Cross-sectional views of Shafts-1, 2 and 3

### Shaft-1: Skip and Hoisting Shaft

Shaft-1 has a diameter of 8 m and is designed to include a cage-counterweight system in order to serve for personnel and material transportation and skip-skip (double skip) system for coal extraction (Figure 2-14). It contains a single cage with two decks and each deck can carry a 5 m<sup>3</sup> mine car. Shaft rope system is planned with guide and koepe. Fresh air intake will be via this shaft.

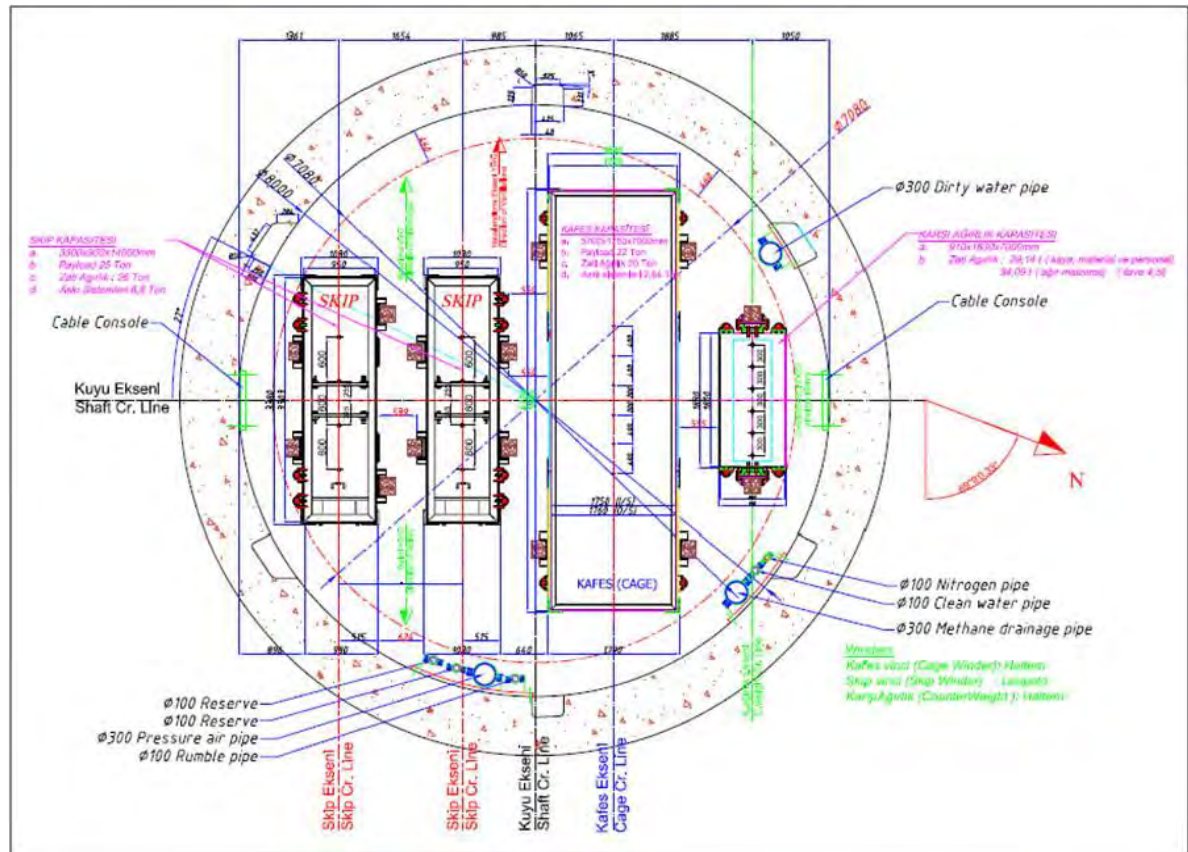

Figure 2-14: Sectional drawing of Shaft-1

Hoisting is planned to be done with shaft stations, 5 m<sup>3</sup> volume mine car circulation on 150 m length part, integrated with main belt conveyor system.

### *Shaft-1 Station Coal Haulage (Belt Conveyor Route):*

Coal produced will be transported to three silos, each having 500 ton capacity, by a 24 m<sup>2</sup> section and concrete supported gallery at Shaft-1. Coal will be transported to the skip loading station by belt conveyor in the gallery under silos. Here, coal will be automatically loaded to skip hoisting system and will be sent to surface (Figure 2-15).

Production belt will be installed at main roadway 3705. Production of East Block will be transported with belt conveyors to the bottom of Shaft-1 via horizontal galleries 3703, 3705 and inclined galleries 3602, 1612. Production of West Block and Southeast Block will be transported to the Surface Inclined Gallery Entrance (+90 m) inclined gallery 2412, 2502, 2202, 3052 and horizontal galleries 2703, 3053.

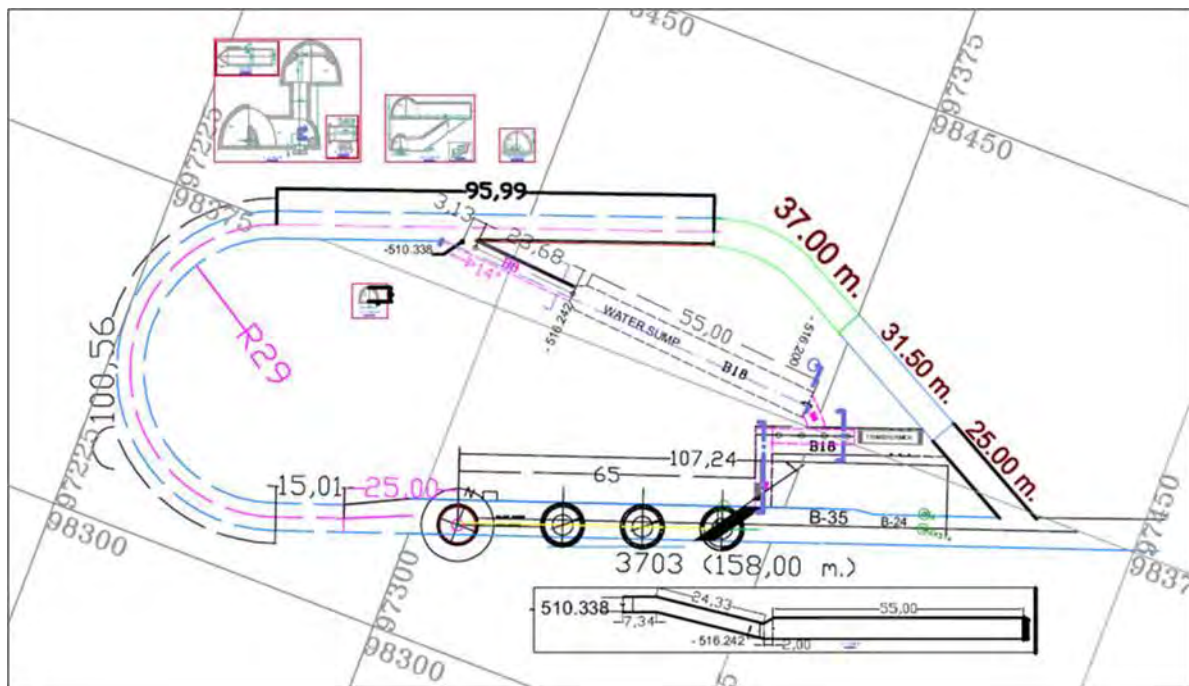

Figure 2-15: Shaft-1 bottom layout (-510 level)

*Shaft-1 Station Material and Personnel Transport (Locomotive Route)*

Empty cars, which will be sent down to -510 level by cage, will be pushed across to the “empty car part” of the shaft station. Loaded cars will be sent to loaded-empty cross-point of the shaft station. From this point cars will be sent to shaft bottom by crane maneuver or chains and will be loaded to cage by a push rod.

Material transportation will be done starting at main roadway 3704. This roadway will be connected to connection galleries and then to the panels. Monorail system will be used for material transportation. Material and personnel transport of East Block will be done via horizontal galleries 3704, 1703 by locomotives and via inclined gallery 1612 by monorail.

Shaft-2: Skip and Hoisting Shaft

Shaft-2 has a diameter of 8 m and is designed as a cage-counterweight system and skip-counterweight system in order to serve for personnel-material transportation and for production by skip. It contains a single cage with two decks (each can carry a 5 m<sup>3</sup> mine car) and 15 tonne capacity skip compartment. Shaft rope system is planned with guide and koepe (Figure 2-16). This shaft will serve as downcast shaft for the West Block.



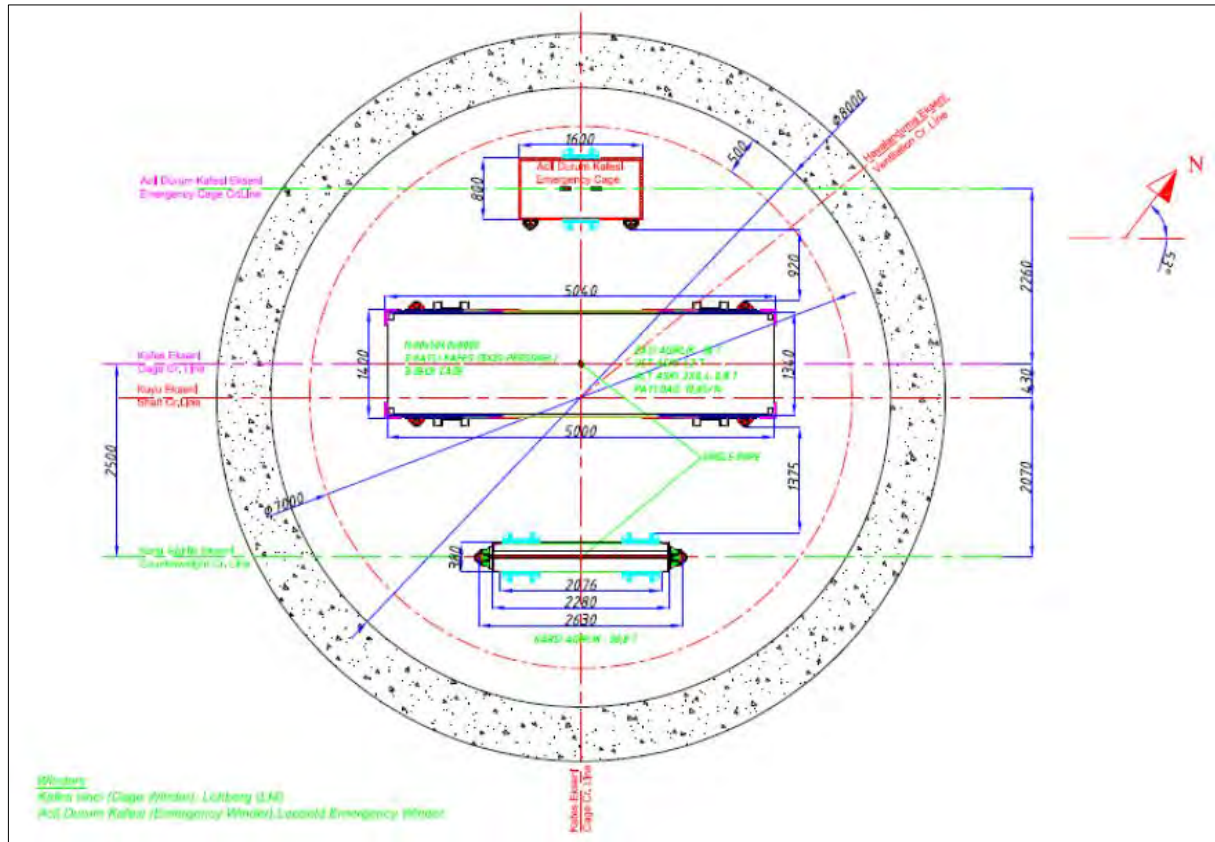

Figure 2-17: Sectional drawing of Shaft-3

### 2.3.6 Galleries

Galleries will be driven with 18 and 24 m<sup>2</sup> cross-sections (Figure 2-18). As noted above, there are three production fields in the Project area that are suitable for full mechanized mining:

- East Production Block (First Operation Field)
- West Production Block (Second Operation Field)
- Southeast Production Block (Third Operation Field)

In total, including shaft stations and water sumps, 34,894 m of galleries will be driven.

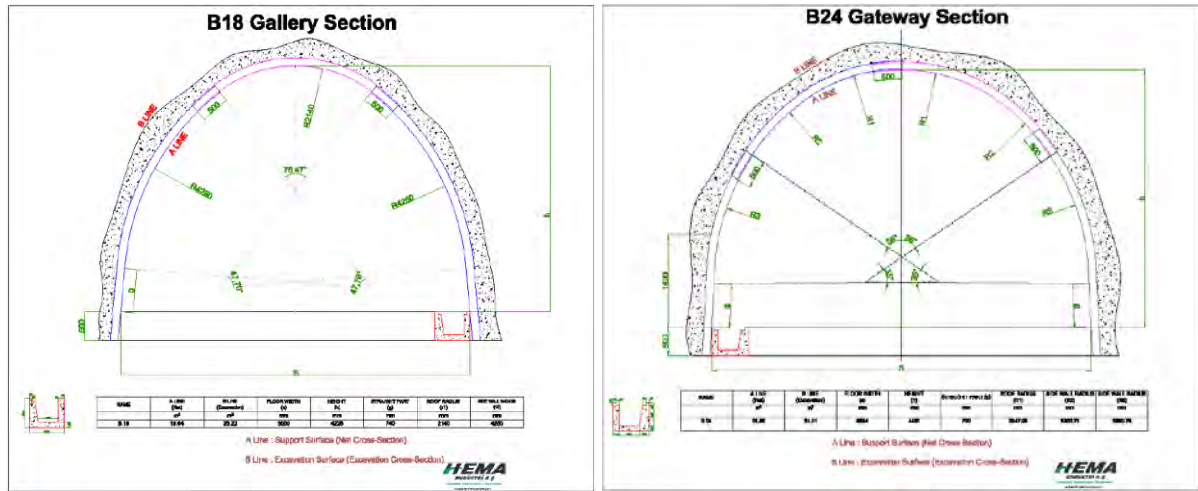

Figure 2-18: 18 m<sup>2</sup> and 24 m<sup>2</sup> galleries typical cross-sectional views

### Galleries of the East Production Block

East Block has an area of 4.2 km<sup>2</sup>. In this area, based on seam correlation studies of four Westphalia-C aged six coal seams between -410 and -530 levels, approximately 45 million tonnes of coal is planned to be produced via production panels and development works. In order to produce this reserve, main roadways from Shaft-1 and Shaft-3 and horizontal and inclined galleries at the production blocks will be driven (Table 2-8).

Shaft-3 and -410 main roadway will serve as return air route. Shaft-1 and -510 main roadway will serve as intake air route for the East Block during development works and as intake air route during production. Shaft-2 and Shaft-1 will also be used as for man and material transport to production areas.

A belt conveyor gallery with 24 m<sup>2</sup> section, to be used for coal haulage, will be driven from Shaft-1 at -510 level. Galleries 1703, 1704 and 1602 will serve fresh air to the production panels.

Table 2-8: Galleries of the East Production Block

Gallery No.	Level	Length (m)	Section (m <sup>2</sup> )	Dip (°)
3603	-410	2641 (1539 m completed)	24	0
3705	-510	1023 (completed)	24	0
Connection gallery		59 (completed)	24	0
1703	-506	1325	24	0
1704	-500.46	53	24	0
1705	-500.46	46	24	0
1702	-500.46/-530.03	391	24	4
1706				
1707				
3703	-510	158 (completed)	24	0
3704	-510	1376 (991 m completed)	24	0
3602	-402/-505	477 (269 m completed)	24	11-14
Connection gallery		107 (completed)	24	0
1602	-403.70/-530	1414	24	5

Gallery No.	Level	Length (m)	Section (m <sup>2</sup> )	Dip (°)
1612	-403.70/-530	1454	24	5
2703	-510	1156	24	0
<b>TOTAL</b>		<b>11678</b>		

#### Galleries of the West Production Block

West Block has an area of 3.7 km<sup>2</sup>. In this area, based on seam correlation studies of seven Westphalia-A aged coal seams between -250 and -800 levels, approximately 37 million tonnes of coal is planned to be produced via production panels and development works. In order to produce this reserve, main roadways from Shaft-2, horizontal and inclined galleries from the surface will be driven. Galleries of the west production block are shown in Table 2-9.

-510 and -610 main roadways will be driven in the West Block. -510 main roadway will serve as intake air route for the West Block and for personnel/material transportation to production panels. -610 main roadway will serve as the intake air route for Southeast Block. Inclined galleries will be used for personnel/material transportation and clean air distribution to production panels and for coal transport. Horizontal galleries will serve as return air route.

Table 2-9: Galleries of the West Production Block

Gallery No.	Level	Length (m)	Section (m <sup>2</sup> )	Dip (°)
2703	-510	1131 (54 m completed)	24	0
2502	-510/-349	695	24	14
2412	-507/-277	931	24	17
2402	-507/-260	859	24	17
3053	+90	461	24	0
3052	+90/+30	402 (completed)	24	0-14
2202	+90/-349	1495 (479 m completed)	24	14
3054	+90	690 (completed)	18	0
2053	+90	138 (completed)	18	0
2252	+90/-213 -213/-227	1922 (100 m completed)	18	16
<b>TOTAL</b>		<b>8724</b>		

#### Galleries of the Southeast Production Block

Southeast Block has an area of 4.1 km<sup>2</sup>. In this area, based on seam correlation studies of two Westphalia-C aged coal seams between -680 and -890 levels, approximately 21 million tons of coal is planned to be produced via production panels and development works.

Galleries that will be driven from Shaft-2 will be used to send intake air to the production panels and personnel-material transportation (Table 2-10).

Table 2-10: Galleries of the Southeast Production Block

Gallery No.	Level	Length (m)	Section (m <sup>2</sup> )	Dip (°)
2712	-505/-607	477	24	14
2803	-610	1061	24	0
4803	-614.50	1669	24	0
4802	-614.50/-890	1138	24	14

Gallery No.	Level	Length (m)	Section (m <sup>2</sup> )	Dip (°)
4904	-890.50	50	24	0
4905	-890	1069	24	0
4703	-513	1398	24	0
4702	-513/-614.50	419	24	14
4803	-614.50	50	24	0
4812	-614.50/-890	1138	24	14
4903	-890	1069	24	0
2702	-607/-509	892	24	14
2705	-509	782	24	0
2702	-607/-720 -720/-607	702	24	14
<b>TOTAL</b>		<b>11914</b>		

### 2.1.1.2 Main Roadways

Main levels are; at West Block: -610 and -510 levels, at East Block: -410 and -510 levels and at Southeast Block: -510, -610 and -890 levels. Spacing between levels is chosen due to low dipping of coal seams;

- Areas suitable for production at the East Block are dipped to southeast. Dip of seams is between 6°-12°.
- Areas suitable for production at the West Block are dipped to southeast. Dip of seams is between 15°-20°.
- Areas suitable for production at Southeast Block are dipped to southeast. Dip of seams is between 10°-15°.
- Due to low dipping of coal seams, spacing between levels is chosen as 100 m.

#### -410 Level Galleries

- The -410 level gallery 3603 from Shaft-3 will be serve as the return air route. This gallery will be connected to gallery 3705 from Shaft-1, via the inclined gallery 3602.

#### -510 Level Galleries

- During East Block production phase, 24 m<sup>2</sup> section galleries 3704 and 1703, that connect to intake air Shaft-1, will be used as fresh air route. At the same time, it will be used for personnel and material transportation to the faces.
- During West Block production phase, 24 m<sup>2</sup> section galleries 2703 and 2803 that connect to intake air Shaft-2 will be used as fresh air routes. Whilst West Block seams WA500, WA600 and WA700 are being produced, gallery 2703 will serve as return air route.
- During Southeast Block production phase, 24 m<sup>2</sup> section gallery 4703 that connects to return air Shaft-2, will serve as return air route. At the same time, this gallery will be used for coal transportation from faces.



### -610 Level Galleries:

- During Southeast Block production phase, 24 m<sup>2</sup> section -610 level gallery 4703 that connects to intake air Shaft-2 will serve as intake air route. At the same time, this gallery will be used for personnel and material transportation to the faces.

#### *2.1.1.3 Cross Cut Galleries and Intervals*

Average face length is 220 m in the West Block, 204 m in the East Block and 207-242 m in the Southeast Block. Cross-cuts will be driven to serve for ventilation, material, personnel and production purposes.

#### *2.1.1.4 Gateways*

During the development process, a total of 236,706 m will be driven as gateways. From development works approximately 5.6 million tonnes of coal will be extracted. Gateways are planned as 600-2200 m for fully mechanized panels.

Dismantling period of face is planned as 250 days for 2200 m panel length, average 2 m seam and 8.8 m advance per day. Maingates will be used as tailgate of the next panel. Therefore, maingates will serve 295 more days including installation period.

#### *2.1.1.5 Coal, Material and Personnel Transportation*

Coal, material and personnel transportation plan for the mining project is presented in Figure 2-19.

### Coal Haulage Roads and Equipment

In the East and West Blocks, coal coming from stage-loader located in maingate will be transported with 1200 mm-wide and 2200 m-long belts to the cross cut conveyor. Working speed will be 2 m/s and capacity will be 2000 tonnes/h. Belt will be selected to have strength of 1300 N/mm. All drums of the belt conveyor system will be rubber-finish and belt will be roof suspended. Tension and storage units will be available in belt conveyor systems.

In the East Block, coal cut at the face will be loaded to belt conveyor (located in gateway) from stage-loader and then conveyed to the silos at bottom of Shaft-1. In the West Block, coal cut at the face will be loaded to belt conveyor (located in gateway) from stage-loader to galleries 2412, 2703, 2502 and 2202 in order to be hauled to surface.

In the Southeast Block, coal coming from stage-loader will be transported with 1200 mm-wide and 2200 m-long belt conveyors, which will be transferred from the East Block mechanized panels to the cross cut conveyor. Tension and storage units will be available in belt conveyor systems. Coal cut at the face will be loaded to belt conveyor (located in gateway) from stage-loader and then conveyed to belt conveyor in the West Block.

---

### Personnel and Material Transportation

#### *East Production Block*

Personnel and materials will be transported with the cage system in Shaft-1 from surface (+86.50 m) to -510 level. After that point bottom-railed battery-locomotives will be used along horizontal roadways (%0.3 inclinations). In the inclined galleries, roof-suspended monorail system will be used between -500.46 and -419.47 levels and between 500.46 and 529.25 levels with 5° inclination. For this system, diesel monorail will be used. Face equipment will be transported with monorail to the gateways and with hydraulic winches in the face.

#### *West Production Block*

Personnel and materials will be transported with the cage system in Shaft-2 from surface to -510 level. After that point bottom-railed battery-locomotives will be used along the horizontal roadways (800 m). Roof-suspended monorail system will be used for transportation in inclined galleries. For this system, diesel monorail will be used. Face equipment will be transported with monorail to the gateways and with hydraulic winches in the face.

#### *Southeast Production Block*

Personnel and materials will be transported with the cage system in Shaft-2 from surface to -610 level. After that point bottom-railed battery-locomotives will be used along horizontal roadways (1675 m). In the inclined galleries, roof-suspended monorail system will be used for transportation. For this system, diesel monorail will be used. System will be transferred from East Block after the production activity is completed there. Face equipment will be transported with monorail to the gateways and with hydraulic winches in the face.

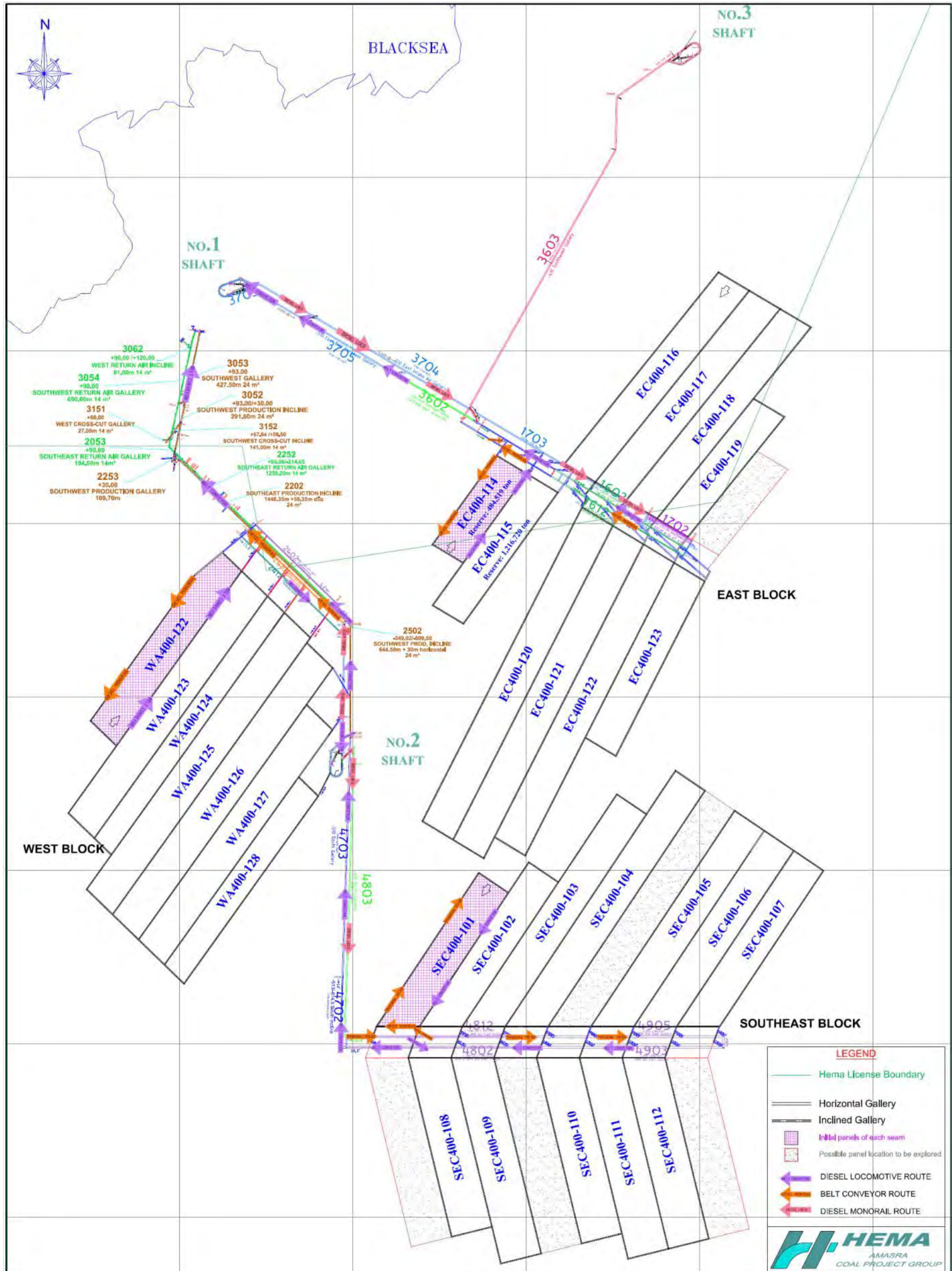

Figure 2-19: Coal, material and personnel transportation plan

## 2.3.7 Production

### 2.1.1.6 Production by Full Mechanized Longwall Mining (Main Project)

As noted earlier, the licence field covers an area of 50 km<sup>2</sup>, in 14 km<sup>2</sup> of which HEMA has the right to mine below -400 level and in 35.6 km<sup>2</sup> of which HEMA has the right to mine from surface. Mining plan has been prepared for three mining fields namely, East Block, West Block and Southeast Block.

HEMA has designed the mining plan that takes into account the proximity of the coal seams to be mined, the likely geotechnical conditions and the need to operate effectively and safely. The production layout is based on utilising a full extraction of the seam without pillars.

Typical longwall equipment are shown in Figure 2-20. Full mechanized longwall mining system with shearer loaders/plow and compatible powered support according to conditions will be applied since seam thicknesses vary at production blocks. Production will be done by drum shearers that have 0.8 m cutting depth and 7.29-12.34 m daily advance capacity, at 207-240 m long faces where coal thickness is 2 m.



Figure 2-20: Typical longwall equipment

Operation will be done in four shifts of which three are for production and one for maintenance. Shearer loader will produce 6000 tonnes of ROM (run-of-mine) coal per day and plow will produce 3500 tonnes of ROM coal per day. 13,000-15,500 tonnes daily ROM coal production from three full mechanized panels is planned.

The typical underground set-up for longwall mining is shown on Figure 2-21. A schematical representation of the longwall mining process is provided in Figure 2-22.

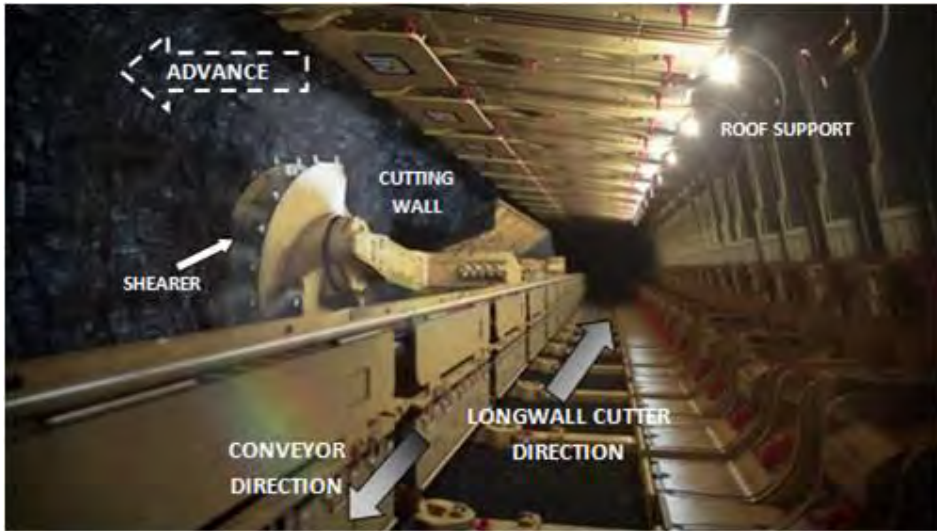

Figure 2-21: Typical set-up for longwall mining process

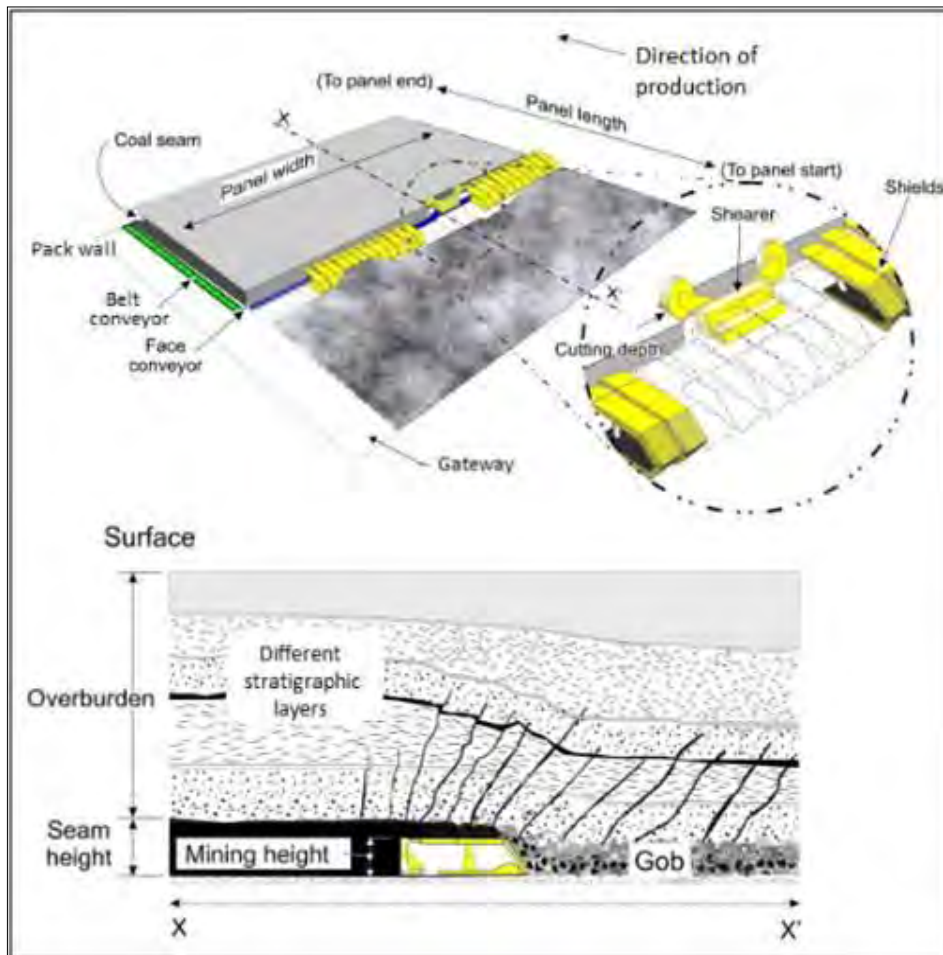

Figure 2-22: Schematical representation of the longwall mining process

---

### East Block Production Planning

In East Block, production panels are named as EC100-101, EC100-102 and so on from north to south. Longwall faces will be operated as single cut, retreat and back-caving. Face width will be 204 m and panel length will be 650-2200 m. The tailgate is also allowed to cave, but maingate is supported with pack walls and maintained for the next panel. Width of pack walls will be 4-8 m and height will be the same with the excavated height. The maingate of a former panel will be used as the tailgate of the latter panel. The main reason why the back-caving U-type longwall has been chosen for the production method is that, Westphalia-C coal in the production Block has high spontaneous combustion risk.

Faces will be supported with minimum 1800 mm high moving power supports. Double drum shearer will cut coal seams having 4 m maximum thickness. Cutting capacity will be at least 1900 tonnes/h. Coal will be loaded to armored face conveyor (AFC) and conveyed to the stage loader. Particle size will be reduced to desired size with the crusher mounted on the stage loader. From stage loader coal will be loaded to belt conveyor and transported to the shaft bottoms.

### West Block Production Planning

In West Block, production panels are named as WA100-101, 102 and so on from north to south. Longwall faces will be operated as single cut, retreat and back-caving. Mining method will be same with East Block.

Double drum shearer will cut coal seams having 2 m thickness and 1.68 tonne/m<sup>3</sup> density. Cutting capacity will be maximum 1500 tonnes/h. In WA-100, 300, 400, 500, 600 and 700, plow will cut coal seams having 1.1 m thickness and 1.68 tonnes/m<sup>3</sup> density. Cutting capacity will be maximum 750 tonnes/h. Coal will be loaded to AFC and conveyed to stage loader. Particle size will be reduced to desired size with the crusher mounted on the stage loader. From stage loader coal will be loaded to belt conveyor and transported to the shaft bottom. Face will be supported with minimum 1000 mm maximum 2500 mm-high powered roof supports.

### Southeast Block Production Planning

In Southeast Block, production panels are named as SEC400-101, SEC400-102 and so on from north to south. Longwall faces will be operated as single cut, retreat and back-caving. Face width will vary between 207 m and 242 m and panel length will be 788-1681 m.

In SEC400, double drum shearer will cut coal seams having 4 m (max.) and 1.68 tonne/m<sup>3</sup> density. Cutting capacity will be at least 1900 tonnes/h. Coal will be loaded to AFC which has at least 2000 tonne/h capacity. Face will be supported with minimum 2000 m high power supports.

In SEC500, plow will cut coal seams having 1.1 m (max.) and 1.68 tonne/m<sup>3</sup> density. Cutting capacity will be at least 1500 tonnes/h. Coal will be loaded to AFC which has at least 2000 tonne/h capacity.

---

Face will be supported with minimum 1000 m high power supports. Coal will be loaded to AFC and conveyed to stage loader. Particle size will be reduced to desired size with the crusher mounted on the stage loader. From stage loader coal will be loaded to belt conveyor and transported to the shaft bottoms.

Production method and planning for the production fields are further detailed in Annex B. Coal produced and conveyed to surface will be processed in the coal washing plant and transported to the nearby bulk cargo quay which will be constructed within the scope of the Project and then be transported to the quay from coal washing plant by means of a belt conveyor.

#### *2.1.1.7 Packwall System*

As for the mining method to be applied, maingates will be used for a second time in the adjacent panels of same seam as tailgate. In order to make maingates remain steady for sufficient time, pack wall system will be applied for the whole length of “coal-produced-panel-side” of the maingate. The reason pillar system has not been chosen instead of pack wall system is that disturbed pillars under stresses will lead to reserve loss and spontaneous combustion. Moreover, in order to prevent stress disturbance of upper level seam gateways to the below level seam gateways, gateway axis will be out of effect area of upper gateways.

After supported and maintained, maingate of a panel will serve as the tailgate of next panel. It will be supported with packwalls in order to reduce the deformations to the gateway supports caused by the stresses. Based on experience from the similar operations, the width of pack walls will be around 4 m and height will be the same with the excavated height.

#### *East Production Block*

In the East Block, four silos having 100 tonne capacity will be constructed on Shaft-1 surface layout for packing system. Two of them will be used for cement storage and the remaining two will be used for dry mixture storage (Figure 2-23). The dry mixture from the silos will be sent to -410 underground subsilo through pipes with compressed air. Aggregate will be sent to smaller subsilos located in the gateway. Water will be added to the dry mixture in this subsilo. Water added mixture will be pumped by concrete pump from the subsilo to the location where packing will be applied. Neutral sodium-silicate at 1.5-2% will be used as setting accelerator.

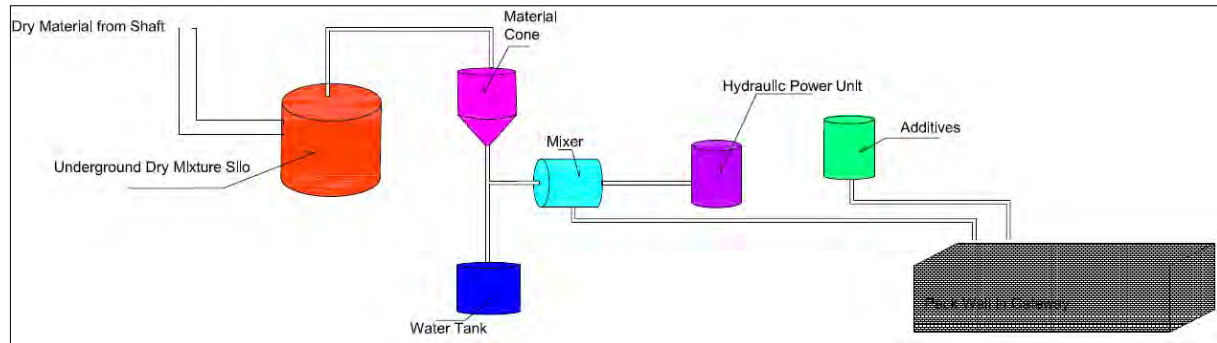

Figure 2-23: Pack Wall System

### West Production Block

Four silos having 100-tonne capacity will be constructed on surface inclined gallery entrance location for packing system. Two of them will be used for cement storage and the remaining two will be used for dry mixture storage. The dry mixture from the silos will be sent to -510 underground subsilo through pipes with compressed air. Water will be added to the dry mixture in this subsilo. Water added mixture will be pumped to the gateways by concrete pump from the subsilo. Neutral sodium-silicate at 1.5-2% will be used as setting accelerator.

### Southeast Production Block

Packing system units of East Block at Shaft-1 will be transferred to Shaft-2 after the production activity in East Block is completed.

Four silos having 100-tonne capacity will be constructed on Shaft-2 surface layout for packing system. Two of them will be used for cement storage and the remaining two will be used for dry mixture storage. The dry mixture from the silos will be sent to -610 underground subsilo through pipes with compressed air. Water will be added to the dry mixture in this subsilo. Water added mixture will be pumped to the gateways by concrete pump from the subsilo. Neutral sodium-silicate at 1.5-2% will be used as setting accelerator.

#### *2.1.1.8 Production of Shallow Coals (West Block)*

Amasra Hardcoal Project has been planned for -400/-530 levels at East Block, -250/-600 at West Block and -600/-900 levels at Southeast Block. In addition to this, license field covers coals at +90/-20 levels in west area of the field and a shallow coal mining project has been planned for these coal seams. The shallow coal project covers a production reserve of approximately 5 million tonnes of coal. Coal will be produced by conventional and semi-mechanized systems and will be supplied to small industrial plants and utilized for domestic heating purposes.



---

Shallow coal project is going to assist the underground hardcoal mining project by Westphalian-A and Westphalian-C coal seam productions. In this portion of the field, production projects have been prepared for Westphalia-A aged two seams called WSA-100 and WSA-200 together with Westphalia-C aged four seams called WSC-300, WSC-400, WSC-500 and WSC-600. Since the designed panel lengths and face lengths of these seams are insufficient for full-mechanized systems, semi-mechanized production methods will be employed.

Drilling and blasting method will be used to excavate seams having various thicknesses. Seam thicknesses vary between 0.80 m and 4.30 m. Coal will be produced from faces having 77-80 m length, cutting depth will be 0.80 m and 1.20-2.40 m advance is planned per day. Therefore, it is planned to produce 227-800 tonnes/day ROM coal.

#### Proposed Production Method for Shallow Coals

Semi-mechanized retreat longwall with steel support system will be used in West Shallow Block.

In high seams, the coal portions located above proposed hydraulic support type's operational range will be taken from behind the face (gobside). By caving of the roof during demounting phase the coal on the roof comes down. Coal coming with the fallen material will be drawn with a special shovel-like tool from the gobside and transferred to the face conveyor.

One of the issues requiring attention during drawing of the coal from gobside is to ensure the roof has caved completely and immobilized. In case the roof does not cave itself it will be drilled and blasted to provide artificial caving. Another important issue is to avoid taking roof rock together with coal drawn since the roof rock will unnecessarily increase the waste ratio if mixed into the coal. The last important issue is to take coal from gobside as much as possible otherwise the spontaneous combustion risk will increase with the quantity of coal left behind.

3,271,875 tonnes coal reserve is determined as recoverable with semi-mechanized methods. Some possible panel locations where the existing data and/or correlated seam thicknesses are insufficient have been excluded from the reserve estimation and they will be reassessed during underground development activities. Seam dips vary from 4° to 21°.

#### *2.1.1.9 Precautions to Reduce Risks in Production*

##### Risk of Coal Seams

It is possible to encounter risks of coal seam thickness reduction, inclination variations, structural faults (faults and joints) during coal production. In order to reduce these risks, to have more data, current drilling program has been intensified at areas where production will be done. Thicknesses, chemical properties and dips of coal seams at roof and floor will be identified with underground drillings which will be held during gallery openings. Moreover, in order not to affect production process necessary precautions will be taken with the advantage of retreat longwall mining method -

---

identifying thicknesses and dips of coal seams and faults if any during rise headings and gateways. Risks of excavation and mechanization will be reduced with rock mechanics tests of roof and floor rocks of coal seam.

#### Risk of Gas and Dust Outburst

In order to eliminate risks of gas and dust outburst, check borehole drillings will be done with 50 m length at galleries in coal and stone.

During development works, check borehole drillings will be done towards tailgate from maingate. Drill hole interval is planned as 100 m along maingates. Moreover, pressure changes, methane emission in mine, gas characteristics and explosion risk will be evaluated together with electronic systems. Real time personnel locations and emergency communication systems will be installed.

#### Risk of Spontaneous Combustion

Spontaneous combustion in underground coal mines is a well known worldwide issue. Molecular structure and spontaneous combustion risk of Amasra coal has been investigated with laboratory studies. Based on these studies, spontaneous combustion risk in micro scale is evaluated and spontaneous combustion risk is identified as “medium”.

Due to spontaneous combustion risk of Amasra coals, real time CO emission measurements will be done. In order to watch CO emission that might be caused by production activities, sensors will be located in gateways and face ends. Measurements will be controlled 24 hours with central monitoring system.

To reduce fire risk, nitrogen injection will be done in areas where spontaneous combustion is determined. Thus, those surfaces will be cooled and contact with air will be prevented.

#### *2.1.1.10 Subsidence Effect*

Bostanlar village, Karayusuflar and Camlık quarters are located above East Block. Coal will be produced at levels between -450 and -500 under these settlements. Settlements' levels are between +250 and +300 which means the production will take place 700-800 m deep. It was calculated that 54-64 cm subsidence may occur after 8-10 years. In Southeast Block, production will be done 900 m deeper than settlements level. “Stowing” will be done to minimize the subsidence. There is currently no settlement above West Block.

#### **2.3.8 Ventilation**

6-13 m<sup>3</sup>/tonne in-situ methane is measured in coal at production areas according to a geological assessment for Zonguldak basin prepared for TTK. This data has been considered in ventilation

calculations. According to this assessment, specific emissions of Karadon and Kozlu District colliery drifts was measured between 10.1-11.5 m<sup>3</sup>/tonne mined in 1997 (Table 2-11).

Table 2-11: Liberated methane measurement at TTK colliery drifts in 1997

Mining district	Annualized methane liberated (m <sup>3</sup> )	Annualized coal production (tonnes)	Specific emissions (m <sup>3</sup> /tonne mined)
Karadon	7,746,683	675,074	11.5
Kozlu	14,130,940	1,400,482	10.1
Average	21,877,623	2,075,556	10.5

By using the curve of distance effect of surrounding seam methane concentration to the production phase (considering methane concentration at 160 m upper seam, 60 m lower seam and surrounding strata), total methane emission is calculated as 16 m<sup>3</sup> per tonne.

#### Ventilation Plan

East Production Block (First Operation Field) - The ventilation plan uses Shaft-1 for intake air and Shaft-3 for return.

West Production Block (Second Operation Field) - The ventilation plan uses Shaft-2 for intake air and inclined ventilation gallery for return. The existing design has been modified to meet the higher capacity requirements for the ventilation of this area of mining.

Southeast Production Block (Third Operation Field) - Production from Southeast Block is currently scheduled to start in 2028. Ventilation system will utilise the same infrastructure that is provided for West Production Block.

In designing the ventilation requirements for each mining area, HEMA has taken account of the Turkish mining regulations, the anticipated methane emissions from each of the seams in the respective areas, the assumed level of methane drainage capture, maximum acceptable velocities and international good practice.

The key design parameters include:

- Maximum 0.87% methane in all return roadways,
- Maximum 1.25% methane in production face,
- Two simultaneously working longwalls,
- 5 m<sup>3</sup>/tonne methane emission during mining after drainage, and
- Ventilation velocity within the regulated limits.

#### Ventilation (Exhaust) Fans

Ventilation of East Block will be achieved by two ventilation fans (1 main and 1 spare). These fans will be installed at Shaft-3 and will operate at minimum 200 m<sup>3</sup>/sec flow rate each. Ventilation of West

and Southeast Blocks will also be provided by two ventilation fans (1 main and 1 spare) which will be installed at the surface inclined gallery entrance (i.e. entrance of gallery 3053 near Shaft-1) and will operate at 180 to 200 m<sup>3</sup>/sec flow rate each.

Methane Drainage

35% of methane is being planned to be drained with four drainage methods in three phases during development, production and after production. The following four methane drainage methods will be used:

- (1) Intake air and return air cross cut galleries of panels, whose production has finished, are sealed with concrete dams. Stratified sandstone at roof and floor of the panels where production has ended is being considered as “gas-carrier”. Both gas within sandstone and within coal seams at 160 m upper and 60 m lower of the production seam will accrue at gobs. This gas will be drained by gas pipes located behind the concrete dam.
- (2) During development works, gas drainage boreholes will be drilled towards surrounding seams of the gallery.
- (3) Drainage holes will be drilled parallel to inclination with 50 m intervals towards coal seam.
- (4) During production, drainage holes will be drilled 20 m ahead of the face towards the gob side at the main gate. Drainage holes will be 50° inclined towards to face and gob side. The point is to make drainage holes reach areas where pressure and fractures are intensive.

As noted above, drained methane will be vented through ventilation fans to be installed at Shaft-3 and at the surface inclined gallery entrance (i.e. entrance of gallery 3053), using installed pipes for air return. Two methane gas recovery stations are proposed to be installed at these locations, for the purpose of generation of electrical power and heat from the drained methane gas.

**2.3.9 Other Underground Developments**

Compressed Air Facilities

During the mining operations, compressed air is required for operation of the pneumatic drilling machines that are used in gallery excavations, as well as for pneumatically operated pumps, gates, rails and locking/unlocking of cages. Compressed air will be furnished by air compressors to be located at the compressor rooms of each shaft station. Types, capacities and quantities of the compressors to be installed are given in Table 2-12 below.

Table 2-12: Air compressors to be installed at the mine site

Compressor location	Type	Capacity (m <sup>3</sup> /min)	Quantity
Shaft-1 compressor room	SA 120 A	21	1
	SA 250 A	40.5	1
	LGFD-43/8-X	43	1

Shaft-2 compressor room	SA 120 A	21	1
	SA 250 A	40.5	1
	LGFD-43/8-X	43	1
Shaft-3 compressor room	SA 120 A	21	3
	SA 250 A	40.5	1

### Hydraulic Pump Stations

Full mechanized longwall mining employs hydraulic powered supports at faces, while semi-mechanized mining employs hydraulic props for roof support. Both systems require high pressurized fluids, which are delivered by hydraulic pumps to be installed at production blocks.

In the East and West Blocks, the high pressurized fluid required by the power supports and hydraulic props will be supplied by four hydraulic pumps to be installed at each block. Each pump will be rated at 70-90 kw with 115 litre/min and maximum 350 bar capacity. Synthetic boron oil will be used at 1% to prevent corrosion.

In the Southeast Block, the high pressurized fluid required by the power supports and hydraulic props will be transferred from the East Block.

### Water Drainage

At the Project site, since there are no permeable units above coal bearing very thick Carboniferous aged units, no water inflow from surface occurs. Water inflow of the site is from where andesite is outcropped and from meteoric waters. Water drainage is necessary to ensure the continuity and safety of the mining works.

Water has not been a significant problem in the Amasra basin where coal is being produced by TTK since 1968. The current and deepest production level of TTK is -350 m in the south of Tuna Fault. According to the drainage water records of TTK, the existing TTK mine has 2 main water sumps at -100 m and -250 m. Maximum 200 m<sup>3</sup>/day of water is pumped to the water treatment facility located at +24 from -100 sump which is also fed by the -250 sump. The reported daily water inflow is considered as very low. During underground mining activities, 50 m<sup>3</sup> of water is currently being drained.

In the Project, at each shaft bottom station, there will be 600 m<sup>3</sup> capacity water sumps for storing the the drained groundwater. In case water inflow may increase, sump plans are compatible with a parallel second water sump. Water pumps will be used for draining the water from collection sumps in production areas and from the main water sumps at shaft bottoms. Drainage will be done through horizontal piping in galleries and vertical piping within shafts.

Water pumps proposed to be installed at the mine site are listed in Table 2-13 below. Total pumping capacity at the mine will be 540 m<sup>3</sup>/h.

Table 2-13: Water pumps to be installed at the mine site

Location	Engine power (kW)	Flow rate (m <sup>3</sup> /h)	Quantity of pumps
Shaft-1 (-510 water sump)	132	20	2
Shaft-2 (-410 and -510 water sumps)	250	100	4
Shaft-3 (-410 water sump)	132	50	2
Production areas	132	varies	6

Control-Command Center

Entire equipment and machinery working for mine will be integrated to an automation system. Communication between related surface facility and underground will be done via an underground telephone system. Entire equipment underground and on surface will be monitored with a monitoring system installed in command center. Gas status (CO, CH<sub>4</sub>, CO<sub>2</sub>, O<sub>2</sub>, H<sub>2</sub>S) and ventilation status of mine will also be monitored and recorded with monitoring system in command center.

A schematical representation of the planned control and communication network is given in Figure 2-24 below.

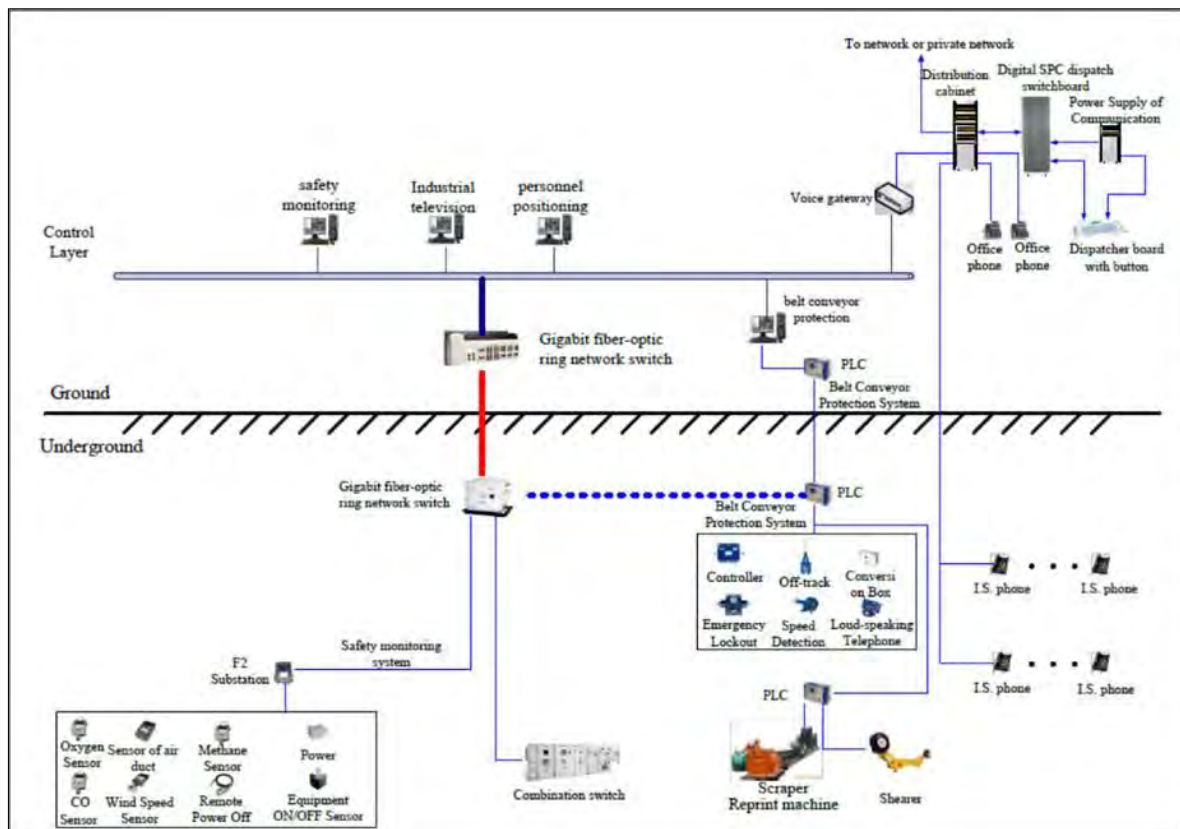

Figure 2-24: Control, communication and the monitoring system

### 2.3.10 Power Supply

Yearly energy requirement for coal production is given below in Table 2-14.

Table 2-14: Energy demand of the mining project by years (in MVA)

Year	Shaft-1		Shaft-2		Shaft-3		TOTAL (MVA)
	Surface Facilities	Underground Facilities	Surface Facilities	Underground Facilities	Surface Facilities	Underground Facilities	
2011-2012	1	1	1	0	1	1	5
2012-2013	1	2	1	3	1	2	10
2013-2014	10	2	1	1	3	2	19
2014-2015	12	8	2	9	3	1	35
2015-2016	12	8	5	9	3	1	38
2016-2017	12	8	5	9	3	1	38
2017-2018	12	8	5	9	3	1	38
2018-2019	12	8	5	9	3	1	38
2019-2020	12	8	6	9	3	1	39

Three power transmission lines that will be fed from the national network are included within the scope of the Project. At present, a power transmission line of 31.5 kV has already been erected. Two additional transmission lines of 31.5 kV and 154 kV will be erected to supply additional power for Project activities. Transmission lines (154 kV and 31.5 kV) to be installed within the scope of the Project will be capable of meeting the power demand of all facilities and installation will be undertaken by HEMA. The 154 kV transmission line will be later expropriated by the Turkish Electricity Transmission Company (TEIAS).

Power demand of all shafts are currently met by their existing 31.5 kV switch and substations. The existing facilities are compatible with new transformer integration. Thus, final transformer and switching stations will be installed over current facilities.

### 2.3.11 Water Supply/Wastewater Generation

In addition to domestic requirements, water is required for mining activities including dust suppression during coal transportation, operation of underground mining equipment and drilling machinery, and concrete production for packwall system. During the construction phase, domestic and industrial water is supplied from the groundwater well HSK-1 with a depth of 300 m located in Kazpınarı near Shaft-2. Drinking water demand is furnished by bottled water. For the operation phase, sea water will be treated to meet the water demand using reverse osmosis process. If it is required water treatment plants will be installed near Shaft-1 and Shaft-2, for treatment of extracted groundwater to bring it to drinking water quality in order to meet the increasing demand due to future personnel increase. Water requirements and means of supply during the construction and operation phases of the Project are detailed in *Chapter 8: Material Resources and Waste Management*.

During operation, industrial wastewater will be generated as a result of water extraction from underground, which includes drained groundwater as well as wastewater originating from underground mining equipment and drilling machinery. Details regarding industrial wastewater management are provided in *Chapter 8: Material Resources and Waste Management*.

### **2.3.12 Waste Rock and Spoil Dumpsites**

Waste rock is generated during during underground construction activities while driving the shafts and approaching the galleries in order to reach the target mineral. Part of this excavated material was used for filling and construction of the Project site whereas the remaining part is currently being deposited into the waste rock dump sites near Shaft-1 and Shaft-2 in accordance with the topography of the surroundings. Additional excavation material will continue to be generated during the coal production.

The spoils, on the other hand, are the materials left during the enrichment process of the coal. Spoils may include inert materials as earth and rock, coal dust and filter press cakes from dewatering or thickening of the residue at the end of the washing process which contain fine coal particulates. If possible, they will be sent to power plants; otherwise they will be primarily deposited at Spoil Dump Site-1 and 2 which have permit from Provincial Directorate of Forestry. They will be covered by soil and vegetated for the pH adjustment of the reject materials. The topography of the disposal sites will be brought into line with the surroundings in order to prevent accumulation of water. After rehabilitation of the field, forestation will be done. Proposed locations of spoil dumpsites are shown in Figure 2-25.

Since spoil dumpsites 1 and 2 is situated in forestry land, a Rehabilitation Project will be prepared in accordance with the "Regulation on Implementation of the 16th Article of the Forestry Law (Official Gazette Date and Number: 30.09.2010/27715; last amended on 07.07.2012)" and submitted to the provincial and regional forestry authorities for the necessary permits. Although the Coal Washing Plant Project Introduction File (PIF) defines a third spoil dumpsite area near Shaft-2 for the disposal of the waste of coal washing plants, the ESIA study identified that this area is currently a waste rock dumpsite area and HEMA declared that only spoil dumpsites 1 and 2 will be used for the disposal of waste generated from coal washing plants.

It should be presented out that these dumpsites are subject to « Regulation on Sanitary Landfill» and the design of these landfills and their approval must have been made by the authorities and a "Sanitary Landfill" license should be obtained. Additionally, the characteristics of the waste of the sites should comply with the limit values defined in the mentioned regulation and should be monitored on a regular basis. Further details on spoil dumpsites are provided in *Chapter 5: Land Use and Zoning* and *Chapter 8: Material Resources and Waste Management*.





Figure 2-25: Locations of proposed spoil disposal sites 1 and 2.

### 2.3.13 Labor Requirements

#### 2.1.1.11 Construction Labor

The present Project construction works are being carried out with a total number of 470 HEMA employees. This number constitutes administrative personnel, engineers, technicians and skilled/unskilled workers. Distribution of engineers and other personnel currently employed by the Project is provided in Table 2-15.

For the construction phase, HEMA has also cooperated with the Chinese DATONG firm and employed foreign workers for installation of the 3 mine shafts. During these works, experienced Chinese mine technicians and workers have been employed (currently 132 employees) and will continue to be employed in future works. Additionally, for driving the galleries, contracts have been signed with Denfa Construction Installation Mining Industry and Trade Co. Ltd. and Soner Engineering, whose 110 and 51 personnel currently serve the Project, respectively.

There is an infirmary available at the Shaft-1 site for first response to accidents, vaccinations and periodic health examinations.

Table 2-15: Distribution of workforce currently employed

Workforce		HEMA	DATONG	Denfa	Soner	Total
Engineer	Mining	25		4	5	34
	Geological	10				10
	Mechanical	9		1	1	11
	Electrical and Electronics	2				2
	Electronic communications	1				1

Workforce		HEMA	DATONG	Denfa	Soner	Total
	Civil	2			1	3
	Environmental	1				1
	Forestry	1				1
	Aeronautical	1				1
	Chemical	1				1
	Geophysics				1	4
	<b>Total</b>	<b>53</b>	<b>0</b>	<b>5</b>	<b>8</b>	<b>66</b>
Technician	Mining	2				2
	Mechanical	5				5
	Electrical	23				23
	Engine	1				1
	Automotive	5				5
	Metallurgy	1				1
	Topographical	3				3
	Ships machinery	1				1
	Mekatronics	1				1
	HVAC	1				1
	Computer	2				2
	Electronic communications	1				1
<b>Total</b>	<b>46</b>	<b>0</b>	<b>0</b>		<b>46</b>	
Administrative personnel		21	5	2	1	29
Guesthouse		9				9
Electrical maintenance		23		6		29
Technical		3		1		4
Operators and drivers		35		13	11	59
Housekeeping		29		2	3	34
Logistics		3				3
Mechanical maintenance		58		9	8	75
Construction		6				6
Driller		21				21
Drill workers		50				50
Underground crane operators		15				15
Underground workers		98	127	72	20	317
<b>Grand Total</b>		<b>470</b>	<b>132</b>	<b>110</b>	<b>51</b>	<b>763</b>

#### 2.1.1.12 Operational Labor

The numbers of employees by years, to be employed for operation of the west block shallow coal mining and the underground mining projects are provided in Table 2-16 and Table 2-17, respectively. Appropriate pre-fabricated facilities will be provided to those employees who need onsite accommodation. The existing infirmary of HEMA (which is located at Gömü Shaft-1 site) will be utilized for health care needs of the workforce. Further details and conditions pertinent to management of the Project labor are provided in *Chapter 16: Labor and Working Conditions*.

Table 2-16: Labor requirement by years for west block shallow coal mining

Year	Number of Employees for West Block Shallow Coals
2013	385
2014	385
2015	497
2016	801
2017	664
2018	566
2019	786
2020	594
2021	769
2022	979
2023	626
2024	139

Table 2-17: Labor requirement by years for underground mining works

Title/ Number of personnel	1.5 million tonnes/year production out of one full mechanized panel (2014-2016)					2.5/3 million tonnes/year production out of two full mechanized panels (2017-2018)					4.5 M tonnes/year production out of three full mechanized panels (2019-2025)					5 million tonnes/year production out of four full mechanized panels (2026-2032)				
					Total					Total					Total					Total
<b>Aboveground Personnel</b>					<b>Total</b>					<b>Total</b>					<b>Total</b>					<b>Total</b>
Mine Director	1				1	1				1	1				1	1				1
Production Superintendent	1				1	1				1	1				1	1				1
Electro-Mechanic Superintendent	1				1	1				1	1				1	1				1
Chief Engineer	3				3	3				3	3				3	4				4
Engineer and Technician	14				14	12				12	12				12	14				14
<b>Underground Workers</b>	<b>Shift 1</b>	<b>Shift 2</b>	<b>Shift 3</b>	<b>Shift 4</b>	<b>Total</b>	<b>Shift 1</b>	<b>Shift 2</b>	<b>Shift 3</b>	<b>Shift 4</b>	<b>Total</b>	<b>Shift 1</b>	<b>Shift 2</b>	<b>Shift 3</b>	<b>Shift 4</b>	<b>Total</b>	<b>Shift 1</b>	<b>Shift 2</b>	<b>Shift 3</b>	<b>Shift 4</b>	<b>Total</b>
Production Team	31	37	31	31	130	62	74	62	62	260	93	111	93	93	390	124	148	124	124	520
Development Team	114	54	120	114	402	114	54	120	114	402	152	72	160	152	536	152	72	160	152	536
Winch Operator	2	1	2	4	9	4	2	4	4	14	4	2	4	4	14	5	3	5	5	18
Switch Operator	7	7	7	7	28	15	15	15	15	60	15	15	15	15	60	20	20	20	20	80
Dam Worker	3	3	3	3	12	6	6	6	6	24	6	6	6	6	24	6	6	6	6	24
Pump Operator	2	2	2	2	8	6	6	6	6	24	6	6	6	6	24	9	9	9	9	36
Repair Crew	7	7	7	7	28	18	18	18	18	72	18	18	18	18	72	30	30	30	30	120
Safety Supervisor	3	3	3	3	12	5	5	5	5	20	5	5	5	5	20	5	5	5	5	20
Safety Worker	4	4	4	4	16	8	8	8	8	32	8	8	8	8	32	8	8	8	8	32
Dynamite Storage Responsible	2	2	2	2	8	3	3	3	3	12	3	3	3	3	12	3	3	3	3	12
Surface Production Personnel	4	4	4	4	16	15	15	15	15	60	15	15	15	15	60	24	24	24	24	96
Surface Workshop Personnel	6	6	6	6	24	12	12	12	12	48	12	12	12	12	48	17	17	17	17	68
Surface Auxiliary Service Personnel	5	5	5	5	20	8	8	8	8	32	10	10	10	10	40	18	18	18	18	72
Surface Coal Washing Plant Personnel	6	6	6	6	24	9	9	9	9	36	9	9	9	9	36	14	10	14	14	52
Methane Drainage Personnel	4	4	4	4	16	8	8	8	8	32	8	8	8	8	32	12	12	12	12	48
Rail Transportation Personnel	3	3	2	4	12	5	5	4	4	18	5	5	4	4	18	10	10	10	10	40
Other (Office)					18					18					18					20
Sub-Total					783					1164					1436					1794
<b>TOTAL (above and under-ground)</b>					<b>797</b>					<b>1182</b>					<b>1454</b>					<b>1815</b>
<b>Total labor requirement considering 20% absence rate</b>					<b>956</b>					<b>1418</b>					<b>1745</b>					<b>2178</b>

## 2.4 Coal Washing Plants

### 2.4.1 Coal Washing Plants Overview

HEMA is planning to construct two coal washing plants as part of the Project. The extracted steam coal will be transported to the Amasra Mine Coal Washing Plant (thereafter referred as ACWP) and the coking coal will be transported to the Shallow Coal Washing Plant (thereafter referred as SCWP). Coal washed will be temporarily stored at the stock yards located next to the coal washing plants.

ACWP with two modules of 500 tonnes/h (TPH) feeding capacity will be located near Shaft-1 (Gomu) and SCWP with one module of 200 TPH feeding capacity will be situated close to the inclined gallery entrance (Figure 2-25). ACWP will be built on an area of 8000 m<sup>2</sup> and SCWP will be built on an area of 900 m<sup>2</sup>.

Construction timeline for the coal washing plants is provided in Table 2-5. Anticipated life cycle of both plants is approximately 30 years.

#### 2.1.1.13 Need for the Coal Washing Plants

Coal extracted in the area has lower calorific value than required by the market. Coal hauled to surface will be processed in coal washing plants in order to increase the calorific value of the coal and to meet the market demand. Calorific value of the coal is increased by mechanical removal of impurities such as rock, middlings, minerals, ash and contamination.

#### 2.1.1.14 Project Technology

ACWP consists of run-of-mine (herein referred as ROM) feed circuit, coarse-coal wash circuit (by -100+10 mm heavy-media drum), fine-coal wash circuit (-10+0.5 mm, three-product heavy-media cyclone, slime dewatering (-0.5 mm spirals) and wastewater treatment plant and vacuumed disc filter for thickening and sludge removal.

SCWP consists of ROM feed circuit, coarse-coal wash circuit (by -100+18 mm heavy-media drum), fine-coal wash circuit (-18+0.5 mm, three-product heavy-media cyclone, slime dewatering (-0.5 mm spirals) and wastewater treatment plant and vacuumed disc filter for thickening and sludge removal.

### 2.4.2 Amasra-Mine Coal Washing Plant (ACWP) Process Details

**1. ROM Feed Circuit:** The coal delivered from the mine to the coal washing plant is called run-of-mine (ROM) coal. Delivered ROM coal is hauled to ROM silos and to ROM bunker by belt conveyors. ROM coal is fed to 100 mm dry screens via palette belts with feeding capacity of 500 TPH of adjustable feed rate. Passing material is sent to wash unit feeding belt. Retaining coal is sent to roll crusher to reduce the size by crusher belt and proceed to 18 mm wet-screens for grading.

**2. Coarse-Coal Wash Circuit (-100+10 mm):** +10 mm graded raw coal is discharged at First Heavy-Media Drum where the refuse is separated from the coal. In a heavy-medium wash, all the cleaning is

done by flotation in a medium of selected specific gravity, maintained by a dispersion of finely ground magnetite in water. Gravity separation method uses a material such as ‘magnetite’ to form a medium denser than water to assist in separation. The freed medium is discharged from washer to coal-rinse screens located under the drum for magnetite recovery and for final grading of +10-18 mm and +18-100 mm. Graded clean coal is then hauled to the packaging facility.

The refuse proceeds to Second Heavy-Media Drum and then Shared Schist-Mikst Screen where coal is separated as schist and mikst. Freed medium is discharged from washer to “refuse rinse” screens located under the drum for magnetite recovery. Clean coal is sent to separate Mikst Silo and Schist Silos by corresponding belts.

**3. Fine-Coal Wash Circuit (-10+0.5 mm):** The fine coal sized -10 mm screened at ROM Feed Circuit wet-screens is combined with magnetite and water. In order to filter the slime in the medium, slime/slurry screens of 3000 mm length x 4800 mm width with 0.5 mm diameter with Cr-Ni surface are used. Screened and rinsed medium is processed to Slime/Slurry Tank by troughs. The process following Slime/Slurry Tank is described in step 2.

Retaining raw fine coal sized +0.5 mm proceeds to Heavy-Media Cyclone Tank and pumped to 850/600 mm diameter Three-Product Heavy-Media Cyclone by 10-inch x 8-inch diameter heavy-media cyclone pump.

Separated clean coal (sized +0.5-10 mm) in cyclones is processed to Shared Schist-Mikst Screen where coal is separated as schist and mikst and rinsed for magnetite removal. Then, it is sent to Centrifuge Dryers for dewatering.

**4. Slime Dewatering (-0.5 mm):** As described in step 3, screened and rinsed medium is processed to Slime/Slurry Tank. Next, the medium is pumped to four 14-inch diameter slime cyclones by slime pumps. A cyclone is a conical vessel in which coal along with finely ground magnetite (media) is pumped to an inlet and short cylindrical section followed by a conical section where separation takes place.

Passing coal from slime cyclones sized +0.15-0.5 mm is sent to spirals for further separation. The coal is separated at Spiral Schist-Mikst Screen and Clean Coal Screen. Spiral clean coal and spiral schist blend is sent to thickener having 1830 x 3850 mm polyurethane screens and double vibrator motor. Retaining coal of slime cyclones is described in step 5. Clean coal is sent to vertical centrifuge for final drying.

**5. Wastewater Treatment Plant and Vacuumed Disc Filter:** Retaining coal from slime cyclones of -0.100 mm is sent to Thickener Tank (12 m in diameter) and settled by the addition of polymer. Effluent water is recirculated in the system and used as process water. Sludge accumulated at the bottom of the thickener is suitable to be dewatered by vacuumed disc filters and used as a fuel source.

### 2.4.3 Shallow Coals Washing Plant (SCWP) Process Details

**1. ROM Feed Circuit:** Delivered ROM coal is hauled to ROM silos and to ROM bunker by belt conveyors. ROM bunker has a capacity of 75 m<sup>3</sup>. ROM coal is fed to 100 mm dry screens via 650 mm wide belts with a feeding capacity of 200 TPH of adjustable feed rate. Passing material is sent to wash unit feeding belt. Retaining coal is sent to roll crusher to reduce the size by crusher belt and proceeds to 10 mm wet-screens for grading.

**2. Coarse-Coal Wash Circuit (-100+10 mm):** +10 mm graded raw coal is discharged at First Drewboy Separator where the refuse is separated from the coal similar to heavy-media drums. The heavy media is obtained by mixing water and magnetite. Gravity separation method uses a material such as 'magnetite' to form a medium denser than water to assist in separation. Drewboy Separator generates clean coal and discard.

The freed medium from drawboy is discharged to coal-rinse screens located under the drawboy separator for magnetite recovery and for final grading of +10-18 mm and +18-100 mm. Graded clean coal is then hauled to packaging facility.

The refuse is sent to Second Drewboy Separator and sent to Shared Mikst and Schist Screen followed by magnetic separator to be rinsed at clean coal screens. The clean coal is hauled to separate Mikst Silos and Schist Silos via belts for storage.

**3. Fine-Coal Wash Circuit (-10+0.5 mm):** The fine coal sized -10 mm screened at the "ROM Feed Circuit" wet-screens is combined with magnetite and water. In order to filter the slime in the medium, slime/slurry screens are used. Screened and rinsed medium is processed to Slime/Slurry Tank by troughs.

Retaining raw fine coal sized +0.5 mm at slime screens proceeds to Heavy-Media Cyclone Tank and pumped to Three-Product Heavy-Media Cyclone by 8-inch x 6-inch diameter heavy-media cyclone pump for dewatering. The process is described in step 4.

Separated clean coal (sized +0.5-10 mm) in cyclones is processed to Shared Schist-Mikst Screen where coal is separated as schist and mikst and rinsed for magnetite removal. Then it is sent to Centrifuge Dryers as a part of dewatering process.

**4. Slime Dewatering (-0.5 mm):** As described in step 3, passing rinsed medium screened at -0.5 mm is processed to Slime/Slurry Tank. Then the medium is pumped to 20-inch diameter slime cyclone by slime pump. A cyclone is a conical vessel in which coal along with finely ground magnetite (media) is pumped to an inlet and short cylindrical section followed by a conical section where the separation takes place.

Passing coal from slime cyclones sized +0.15-0.5 mm is sent to spirals for further separation. The coal is separated at Spiral Schist-Mikst Screen and Clean Coal Screen. Spiral clean coal and Spiral schist blend is sent to thickener for further dewatering. Clean coal is sent to vertical centrifuge for final drying. Retaining coal of slime cyclones is described in step 5.

---

**5. Wastewater Treatment Plant and Vacuumed Disc Filter:** 0.150 mm retaining coal from slime cyclones is sent to Thickener Tank (7 m in diameter) and settled by the addition of polymer. Effluent water is recirculated in the system and used as process water. Sludge accumulated at the bottom of the thickener is dewatered by vacuumed disc filters.

#### **2.4.4 Power Supply**

Energy required during the operation of both plants will be provided by 31.5 kV energy lines with until the construction of main energy line of 154 kV is completed. Transformers for ACWP and SCWP have capacity of 3 MVA and 1 MVA, respectively. Power input and output is designed as 10/0.4 kV.

#### **2.4.5 Water Supply/Wastewater Generation**

An estimated amount of 240 m<sup>3</sup>/day fresh water will be needed for the coal washing plants. This water will be supplied from the effluent of the industrial wastewater treatment plant (i.e. serial settlement tanks) of the mining project.

Both ACWP and SCWP are closed-loop systems and no wastewater will be generated. Therefore, it is not projected to construct an industrial wastewater treatment plant. Wastewater at fine-coal and coarse-coal wash circuits, slime dewatering and vacuumed disc filters will be collected and recycled within both systems.

During the construction and operation phases, domestic water demand of the coal washing plants personnel will be supplied from the existing well HSK1 near Shaft-2 and the additional water supply wells to be installed as part of the Project. Domestic wastewater generated during construction and operation phases will be transferred to the package wastewater treatment plant to be constructed as a part of the coal mining project.

#### **2.4.6 Labor Requirements**

It is anticipated that 20 personnel will be employed during the construction of the coal washing plants.

52 personnel in four shifts (6 hours/day) will be employed for the operation of Amasra-Mine Coal Washing Plant (ACWP). 24 personnel in three shifts (6 hours/day) will be employed for the operation of Shallow Coal Washing Plant (SCWP). 10 personnel are added to the number of personnel employed for the operation of both ACWP and SCWP as contingency (for absence, illnesses, vacations and incidents) totaling the number of employees to 86.

Construction and operation workforce will be supplied locally to the extent possible. Appropriate pre-fabricated facilities will be provided to those employees who need onsite accommodation. The existing infirmary of HEMA (which is located at Gomu Shaft-1 site) will be utilized for health care needs of the workforce. Further details and conditions pertinent to management of the coal washing plants labor are provided in *Chapter 16: Labor and Working Conditions*.



## 2.5 HEMA Port (Reclamation Area and Quay)

### 2.5.1 HEMA Port Overview

HEMA is planning to construct a new port (reclamation area and quay) to the east of the existing Tarlaağzı Fishery Port in the coastal part of Tarlaagzi Village for shipment of the coal to be produced. Location of the port project is shown in Figure 2-26. The main reason for the maritime transport is the lack of adequate highway and railway networks in the region due to geography and rough topographical conditions. Other reasons include less environmental impacts and the low cost of the maritime transport compared to other transportation means. With the port investment, up to 5.7 million tons of coal annually produced in the mine area is intended to be handled and also optimize the production and distribution relationship. The overall objective is to fulfill the increasing need of coal in iron-steel, energy and cement sectors in Turkey, and thereby to enhance the national economy.



Figure 2-26: Location of the proposed port project

The port will be constructed within the scope of the Amasra Hard Coal Mine Project. The port is planned to be built on an area of 163,000 m<sup>2</sup> and involves reclamation works and construction of a breakwater, a quay structure and storage yards. Dredging will not be required because of the available depths in the bulk cargo quay basin. The loading process at the port will be carried out via covered conveyor belt systems directly onto the vessel, or if necessary from the storage yard behind the quay onto the vessel.

The operation of the port is envisaged to be started by mid-2017. Up to 5.7 million tons of coal annually produced from the HEMA mine shafts will be transported to Çatalağzı and Eren Thermal Power Plants located in Zonguldak by maritime transport. According to the planned handling capacity of the bulk cargo quay, 173 bulk vessels of 30,000 DWT (dead weight tonnes) will be served annually. The proposed quay will also provide basic port services for the berthing vessels.

The port will be located at a distance of approximately 635 m from Shaft-1 (Gomu), 3400 m from Shaft-2 (Kazpınarı) and 3170 m from Shaft-3 (Amasra). The location of port area with respect to Gömü Shaft-1 of the mine project is shown in Figure 2-27.



Figure 2-27: Location of the port with respect to the Shaft-1 area

### 2.5.2 Other Ports in the Area

Ports and fishery ports that are located in the region are listed in Table 2-18 and shown in Figure 2-28 below. The nearest is the Tarlaağzı Fishery Port, which is located at a distance of 350 m to the southwest of the proposed HEMA port. Amasra Port is located at a distance of 5 nautical miles in the northeast. Distance to the Tekkeönü Fishery Port is approximately 18 nautical miles and distance to the Kurucaşile Fishery Port is approximately 20 nautical miles.

Table 2-18: Ports in Bartın Province

Name	Type	District
Tarlaağzı	Fishery Port	Amasra
Amasra Port	Port/Fishery Port	Amasra
Kurucaşile	Fishery Port	Kurucaşile
Tekkeönü	Fishery Port	Kurucaşile



Figure 2-28: Ports/fishery ports in the area

Tarlaağzı Fishery Port is located 350 m southwest of HEMA Port and has a 620 m long main breakwater and 130 m long side breakwater. Quay lengths are 210 m, 130 m and 170 m (total of 510 m). The port is operated by Fishery Cooperatives of Tarlaağzı and Gömü Villages. The photographs of the Tarlaağzı Fishery Port are shown in Photo 10.

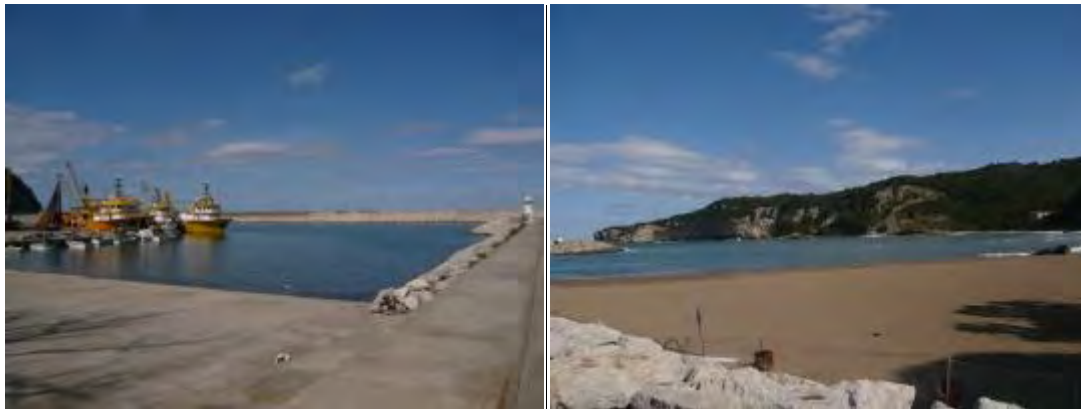

Photo 10. Tarlaağzı Fishery Port

### 2.5.3 HEMA Port (Reclamation and Quay) Project Components and Design

#### 2.1.1.15 Overview

The HEMA Port (Reclamation and Quay) Project will be comprised the following main elements:

- A 494 m long breakwater in the east-west direction for the protection of the quay structures;
- Reclamation (72,000 m<sup>2</sup>) and excavation (22,000 m<sup>2</sup>) works;
- A 250 m x 28 m bulk cargo quay structure at the northern end of the reclamation area, designed to accomodate 30,000 DWT vessels, including 2 piled mooring dolphins and steel catwalks between the quay and dolphins;
- 2 coal stocking yards with a total capacity of 50,000 tonnes, 200 m x 27 m x 8 m (h) each;

- Utilities and pavement works.

In addition to the above, an entrance-exit gate, administration building, workshop, package treatment plant, transformer, roads, parking areas and conveyor lines are included in the construction plan. The port project is anticipated to have a service life of 50 years. The proposed general layout of the HEMA port is shown in Figure 2-29.

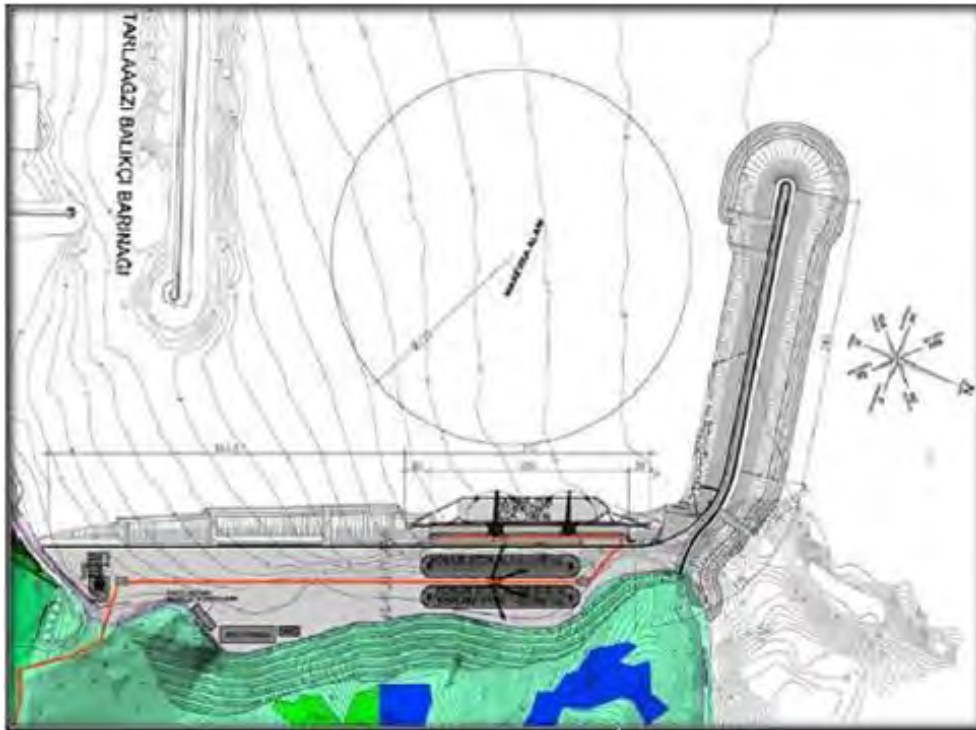

Figure 2-29: HEMA port general layout and components

The properties of the berthing structures to be built as part of the port project are shown in Table 2-19 below.

Table 2-19: Properties of the berthing structures

Structure	Quantity	Length (m)	Width (m)	Depth (m)	Use	Technical Properties
Quay-1 (Bulk cargo)	1	250	27.7	(-14.0) - (-17.5)	Bulk cargo (Hard coal)	Steel pile system/ Reinforced concrete
Mooring dolphins (Quay-1)	2	8	8	(-14.0) - (-17.5)	Mooring	Steel pile system/ Reinforced concrete
Berthing/mooring dolphins (Quay-2)	3	8	8	(-14.0) - (-17.5)	Berthing, mooring	Steel pile system/ Reinforced concrete

### 2.1.1.16 Breakwater

A 494 m long breakwater will be constructed at the northern edge of the port in the east-west direction in order to protect the quays and reclamation areas against waves and to enable quay operations during the majority of the year. The proposed breakwater design was developed according to the results of the "Wave Climate, Wave Transformation and Port Basin Agitation Analysis" study, which was undertaken by the Istanbul Technical University (dated January 2012).

The cross-section of the breakwater is shown in Figure 2-30. The breakwater will be composed of the following layers (from core to the outer layer);

- Core fill (0-0.4 tonne rocks)
- 1<sup>st</sup> rock layer (0.4-2 tonne rocks)
- 2<sup>nd</sup> rock layer (2-4 tonne rocks)
- Protective layer at the outer side
  - Protective layer at the breakwater head : 30 tonne tetrapodes, with 2/1 slope
  - Protective layer at the breakwater trunk : 30 tonne tetrapodes, with 3/2 slope
  - Protective layer at the northern edge of breakwater: 19.6 tonne tetrapodes, with 3/2 slope
- Toe at the outer side (4-6 tonne rocks)

The breakwater crest level is designed as +9.15 m at the northern edge of breakwater and +10.00 m at the remaining breakwater areas. A breakwater crown wall will be situated on the core fill and the 1<sup>st</sup>, 2<sup>nd</sup> rock layers and tetrapodes shown in the section will bear upon the crown wall. The crown wall foundation bottom and top levels are designed as +1.00 and +3.00.

The breakwater depth ranges from -17.50 to -19.50 m.

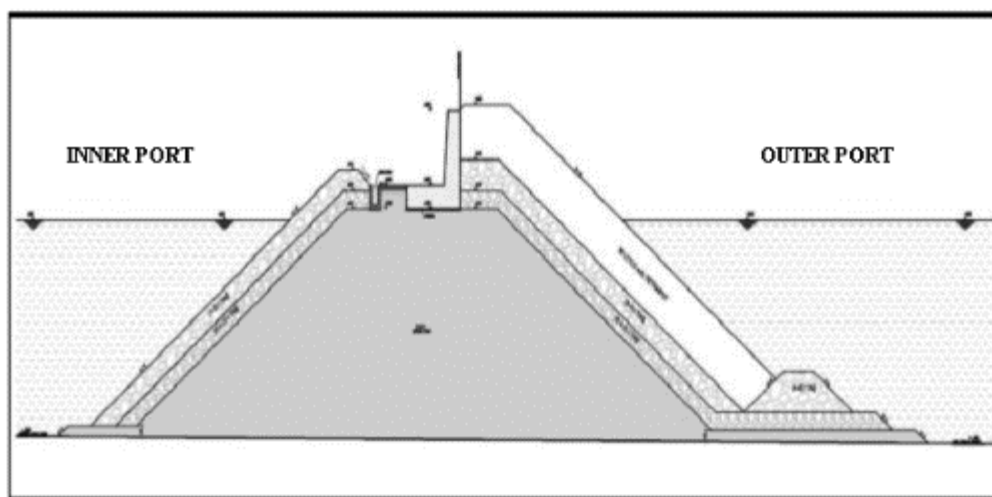

Figure 2-30: Breakwater cross-section

#### 2.1.1.17 Excavation/Reclamation

The project involves excavation/reclamation of the port area. The site excavation and reclamation top level is designed as +2.40 m, and the base, sub-base and pavement level as +3.00 m.

The reclamation area is approximately 760 m long and 90-100 m wide, covering approximately 72,000 m<sup>2</sup> and the area to be excavated is approximately 22,000 m<sup>2</sup>. Reclamation material required for the port construction will be obtained from the slope protection area located behind the quay structure. This area will be sloped for the purpose of stabilization against risks such as landslides. Details regarding the slope protection area are provided in Section 2.5.3.8.

The reclamation area fronts will be protected against extreme waves using 1-3, 2-4, 3-5 and 4-6 tonne category rocks, except for a limited area where 7 tonne concrete cubes will be used as protection.

#### 2.1.1.18 Bulk Cargo Quay

The Reclamation and Quay Project includes a 250 m long and 28 m wide quay at the northern side of the reclamation area, to serve 30,000 DWT bulk cargo vessels (Figure 2-31). The design will also allow two bulk cargo ships of 10,000 DWT and 5,000 DWT to berth the quay at the same time. The quay design includes two mooring dolphins, each located at a distance of 30 m from the quay ends. The top level of the quay and dolphins is +3.00 m. The quay and dolphins will be connected by steel frame catwalk structures. The quay will also include fenders spaced at 13.2 m and 100 tonne bollards spaced at approximately 20-25 m.

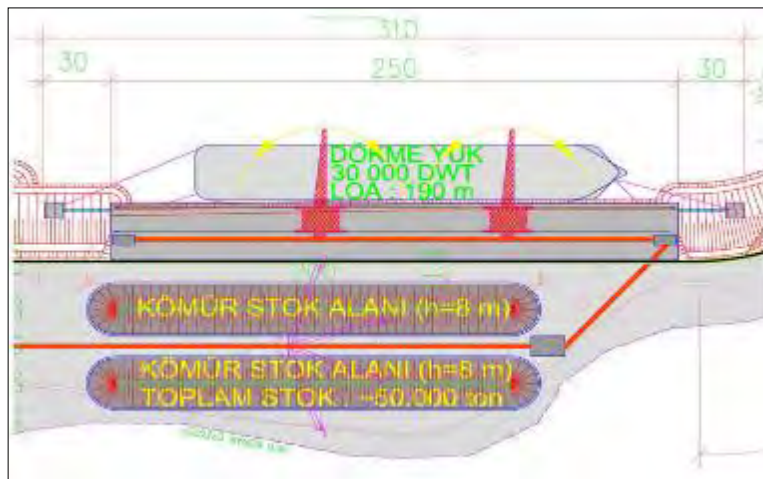

Figure 2-31: Bulk cargo quay general layout

The quay will rest on 1219 mm diameter tubular steel piles with a thickness of 18 mm and steel quality of St44.2. The quay structure will consist of 5 modules, each including 40 piles. The piles will be spaced at 6.60 m intervals in the longitudinal direction. According to the preliminary structural

analysis, the pile lengths are calculated as 37 m. As such, a total pile length of 7,400 m is anticipated for the quay construction.

Prefabricated T-walls will be placed behind the quay structure in order to avoid any horizontal load acting on the quay. The prefabricated T-walls will be placed at -3.00 m on to a 50 cm thick bedding layer which rests on the core fill.

Cross-sectional view of the quay structure is provided in Figure 2-32.

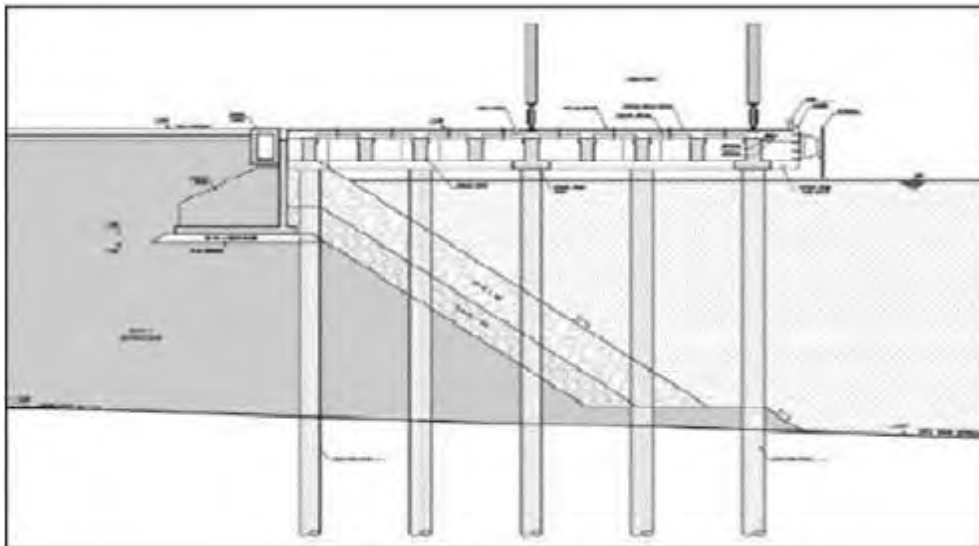

Figure 2-32: Quay structure cross-section

### Mooring Dolphins and Catwalks

The quay design includes two reinforced concrete mooring dolphins of 8 m x 8 m with a concrete thickness of 1.50 m, resting on four driven tubular steel piles of 1219.2 mm diameter, 18 mm thickness and St44.2 steel quality. The pile lengths for the two dolphins are calculated as 23.5 m and 37 m. A 100-tonne bollard will be installed in the middle of each dolphin. The quay and dolphins will be connected via two pre-fabricated steel frame catwalk structures of 22 m length, 1.30 m width and 1.25 m height. A steel mesh walkway at +3.00 m level will be installed on top of the structural system.

#### *2.1.1.19 Dry Bulk Handling and Storage Areas*

On the reclamation area, two coal stocking yards with a total capacity of 50,000 tonnes are considered, in order to meet the temporary storage need in emergency situations. Properties of stocking yards are provided in Table 2-20. The stocking yards will cover a total approximate area of 10,800 m<sup>2</sup>. The possible dust generation in the storage sites will be minimized by water spraying at regular intervals.

Table 2-20: HEMA port coal storage areas

Storage area	Length (m)	Width (m)	Height (m)	Approximate capacity (Ton)
1	200	27	8	25,000
2	200	27	8	25,000

Extracted coals will be transported to the bulk cargo quay via covered conveyor belts. The planned conveyor belt system, to be located at the rear of the quay, will have a capacity of 2000 tonnes/h and will be sized 2 m x 1000 m.

A reinforced concrete rail beam will be installed, for the stacker-reclaimer equipment operating in between the two stocking yards (Figure 2-33). If required, the coal stocking yard can be extended further to the south.



Figure 2-33: Stacking at coal stocking yards using stacker-reclaimer (typical)

#### 2.1.1.20 Other Land Facilities

Land facilities to be constructed as part of the port project will include a 2 storey administration building, entrance-exit canopy and weighbridge, workshop building, transformer house and package biological wastewater treatment plant (for treatment of domestic wastewater). Construction types and areas of these facilities are shown in Table 2-21.

Table 2-21: HEMA port land facilities

Facility	Construction Type	Total construction area (m <sup>2</sup> )
Administration Building	Reinforced concrete/Steel construction	768
Entrance-Exit Canopy and Weighbridge	Reinforced concrete/Steel construction	425
Workshop Building	Reinforced concrete/Steel construction	1400
Package Treatment Plant	Reinforced concrete/Steel construction/Mechanical	350
Transformer House	Reinforced concrete	250



As defined in the Regulation on Reception of Ship-Generated Wastes and Waste Control of Wastes (Official Gazette date/no: 26.12.2004/25682), a waste reception facility will be established on-site in order to receive, store and transfer the operational ship waste.

Infrastructure and Utilities

Infrastructure features of the planned port facility are summarized in Table 2-22.

Table 2-22: HEMA port infrastructure facilities

Infrastructure Facility	Properties
Pavement works	Reinforced concrete/Stabilized
Stormwater drainage system	Corrugated HDPE pipe system and reinforced concrete manholes
Fire water system	PE100 pipe system, underground and aboveground cast hydrants, reinforced concrete control rooms, reinforced concrete pump station and mechanical pump system
Potable water	PE100 pipe system and reinforced concrete manholes, mechanical pressure tank system
Wastewater system	Corrugated HDPE pipe system and reinforced concrete manholes
Power Cable Channels and Lighting System	Corrugated HDPE pipe system and reinforced concrete manholes, lighting column foundations
Electrical Works	Underground cabling systems, lighting columns and panels, transformer and generators, site earthing systems, power transfer line

2.1.1.21 Slope Protection Area Behind Quay

Reclamation material required for the port construction will be obtained from the slope protection area located behind the quay structure. Slope protection will be applied in this area for the purpose of stabilization against risks such as landslides to ensure a safe port layout.

The area behind the proposed quay structure consists of steep rocky cliffs, with observed slopes up to 90° and with elevations starting from +5 m and reaching +75 m in Slope Area #1, +65 m in Slope Area #2 and +35 m Slope Area #3 (Figure 2-34). Hence, slope protection will be executed for safe backfill operations and to provide a measure for catastrophic events such as landslide and earthquake, upon necessary permits are granted. Since main lithology in this area is indicated as limestone, it is not feasible to implement bored pile, rock bolt and anchorage applications. In order to stabilize the site, slope protection in the form of berm is required.

According to the letter of the MEUP dated 8 April 2013, the construction of the slope protection area is exempt from an environmental impact assessment study as per the Turkish regulations. However, the letter also states that the Bartın Provincial Directorate of Environment and Urban Planning should evaluate the issue on the basis of the Bartın Province Local Environment Board’s decision dated 25 August 2011 regarding “prohibition of any mining activities within a distance of 400 m from the shoreline towards inland within visible distance”.

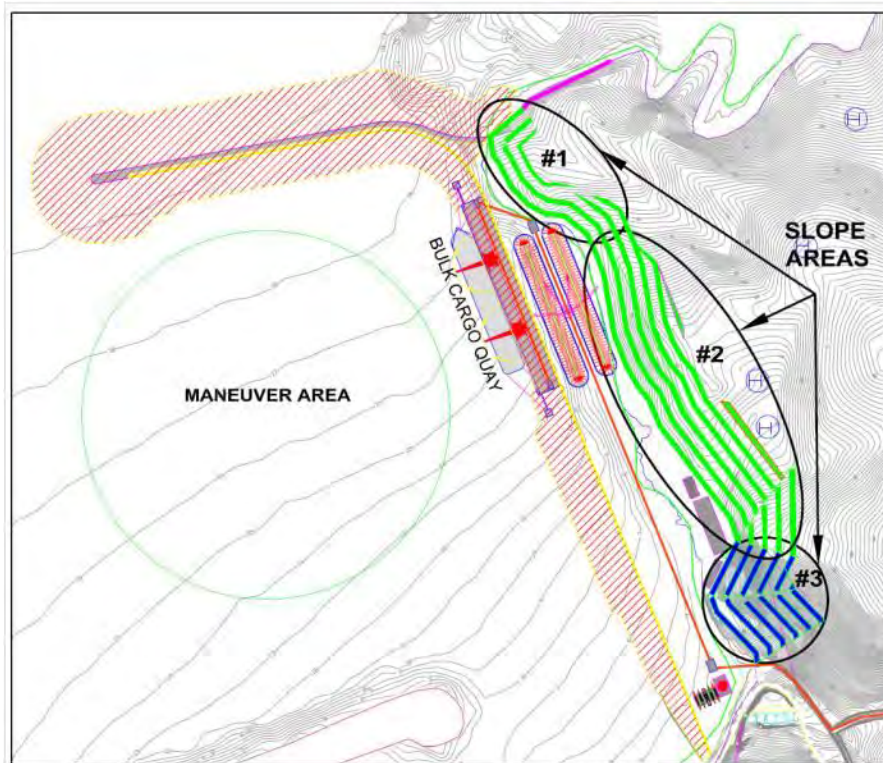

Figure 2-34: Slope area behind the quay

According to the “Slope Protection Kinematic Analysis and Slope Protection Preparation, Revised Report” prepared by Namik Kemal University in September 2013, the total volume of earthwork for slope protection is 1,488,412 m<sup>3</sup> and total volume required for port reclamation is approximately 1,437,538 m<sup>3</sup>. The management of the remaining material (50,874 m<sup>3</sup>) is discussed in *Chapter 8: Material Resources and Waste Management*.

The material to be used in port reclamation is the following: 0-0.4 tonnes; 0.4-2 tonnes and 2-4 tonnes of riprap. Sufficient volume of material at each size will be excavated during slope protection work.

Based on the calculations, the area of slope protection is 56,140 m<sup>2</sup> partially unvegetated and partially vegetated having topsoil reaching 0.3 m depth in some areas. The amount of excavated topsoil will be approximately 29,473 tonnes.

Slope protection berms will be completed in phases. The topsoil will be accumulated on the unexcavated part of the slope protection area. Upon completion the slope protection area, the surface of the berms will be filled with topsoil to preserve the natural pattern of the area. Vegetation and restoration work will commence with the aid of landscape architects implementing appropriate seeding and planting practices.

## 2.5.4 Design Vessels and Navigation

The characteristics of the cargo carriers that will be served by the port are shown in Table 2-23.

Table 2-23: Characteristics of the cargo vessels to be used in the project

Properties	Bulk cargo ships
Capacity tonnage (DWT)	30,000
Load displacement tonnage	40,000
Length (m)	187.0
Width (m)	26.6
Total height (m)	14.4
Load waterline (m)	10.3
Berthing speed (max) (m/sec)	0.13
Berthing angle (max) (°)	6°

As part of the design works, safety analysis of berthing and departure maneuvers of the vessels was carried out by the Istanbul Technical University (January 2012), through simulations using local wind, wave and tidal current data. Based on the results reported in the "Wave Climate, Wave Transformation and Port Basin Agitation Analysis" study, it was concluded that the proposed port should be protected by a breakwater structure to ensure adequate wave protection for vessels (see Section 2.5.3.2). With the proposed configuration, it is estimated that the bulk cargo quay operations may be hindered for an average period of 12-13 days per year due to wave induced agitation, excluding extreme conditions.

A 450 m diameter maneuver circle is planned between the HEMA port breakwater and the existing fishing port main breakwater. The planned maneuver circle is large enough for safe berthing and departure of both the vessels that will be using the port facility and the fishing boats using the current Tarlaağzı Fishery Port. Dredging will not be required because of the available depths in the quay basin.

## 2.5.5 Construction and Operation Timeline

Construction duration of the HEMA Port will be 24 months and the service life will be 49 years. Port construction is estimated to be completed at the end of 2015. Until this time the produced coal will be transported via trucks. The tentative project implementation schedule is provided in Table 2-24.

Table 2-24: Port project tentative implementation schedule

Component	Duration (months)	2014												2015												2016												2017											
		1	2	3	4	5	6	7	8	9	10	11	12	1	2	3	4	5	6	7	8	9	10	11	12	1	2	3	4	5	6	7	8	9	10	11	12	1	2	3	4								
HEMA Port Investment	39	[Green]																																															
Pre-Construction Works (Authorization, Approval, Design and Procurement Process)	10	[Green]																																															
Construction Works	24	[Green]																																															
Excavation-Reclamation Works	20	[Green]																																															
Quay Construction Works (Dolphins and Catwalks Included)	16	[Green]																																															
Utility Construction Works (Fire, Stormwater, Potable Water, Wastewater, etc.)	5	[Green]																																															
Buildings and Other Aboveground Structures (Administrative Building, Canopy, Workshop, etc.)	6	[Green]																																															
Electrical Works (Lighting, Power Distribution, Power Units)	5	[Green]																																															

### 2.5.6 Port Construction

The construction of the port will involve the following activities (in the order of work flow):

1. Reclamation behind quay
2. Breakwater construction (including fill and fill protection)
3. Pile driving and cap concrete installation
4. Assembly of precast beams/pavings and concrete pavement of the quay
5. Reclamation overfill
6. Infrastructure and site pavement works
7. Construction of buildings/aboveground structures and assembly of machinery and equipment.

Reclamation material for reclamation of the quay area will be obtained from the slope protection area (discussed in Section 2.5.3.7). Construction of the quay will involve installation of tubular steel piles into the seabed after which the quay structure will be constructed on top (Figure 2-32). Piles will be driven using floating equipment and subsequently filled with concrete. In design and construction of the quay and other port structures, the technical criteria set forth by the publications of the "Ministry of Transport, Maritime Affairs and Communications, General Directorate of Infrastructure Investments" will be complied with;

- "Technical Regulation on Seismic Design of Coastal Structures, Ports, Railways, Airports" (Official Gazette date/no 18.08.2007/26617; revised 26/12/2008),
- "Technical Specifications for Planning and Design of Coastal Structures and Ports" (2007),
- "Technical Specifications for Materials, Construction, Inspection and Maintenance-Repair of Coastal Structures and Ports" (2008).

### 2.5.7 Port Operation

#### 2.1.1.22 Operational Equipment

Two units of 1000-tonnes/h capacity rail quay cranes will be used for dry bulk handling at the port. The cranes will move over A100 rails installed over the quay's longitudinal crane beams and the rail spacing will be 12 m.

Transfer of coal to the port will be undertaken by a covered conveyor belt system (2000-tonnes/h) that connects the quay to the temporary stocking yard as well as the coal mine. Additionally, a 1500-tonne/h capacity stacker-reclaimer will be operated in the temporary stocking yard for emergency stacking of coal.

A summary of quantities and capacities of the equipment to be used during the operation phase of the port are given below in Table 2-25.

Table 2-25: Summary of operational equipment deployment

Equipment	Capacity	Quantity
Rail quay crane	1000 tonnes/h	2
Covered belt conveyor system	2000 tonnes/h	1
Caterpillar	14-axle, 325 tonnes	1
Hopper	20-30 tonnes	2
Loader	3 m <sup>3</sup> minimum	2
Mini loader	0.5 m <sup>3</sup>	4
Forklift	3 tonnes	2
Weigh-bridge	50-100 tonnes	1
Tow truck	80-100 tonnes	2
Overhead crane	5-20 tonnes	2

A 1400 m<sup>2</sup> workshop is planned to be constructed within the port area, to be used for periodic maintenance and repairs of the operational equipment.

#### 2.1.1.23 Power supply

At HEMA port, bulk handling equipment (i.e. rail cranes), transfer equipment (i.e. covered belt conveyor) and stacking equipment (i.e. stacker reclaimer) will be powered by electricity. When all port operations are considered, it is estimated that there will be a total power demand of 5 MVA. Power to the port will be supplied by the existing power supply network.

#### 2.1.1.24 Emergency Response

An Emergency Response Plan will be prepared before the port is commissioned, in line with the "Law on Response to Emergencies and Compensation of Losses in Case of Pollution of the Marine Environment from Oil and Other Harmful Substances (Law No. 5312)" dated 2005 and its implementation regulation (Official Gazette date/no 21.10.2006/26326). This plan will address the necessary preparedness and response activities for all levels of incidents (including incidents of fire, oil spills, vessel collisions, etc.) that may occur during the port operations.

#### 2.1.1.25 Water Supply/Wastewater Generation

During the operation of the port, the drinking/potable water needs of the 65 employees will be supplied from the groundwater extraction wells of the mining site (i.e. the existing well HSK1 and the additional water supply wells to be installed as part of the Project), which will be transported to the port site through a pipeline.

The generated domestic wastewater will be treated at an on-site package biological treatment plant which will be installed during the construction phase and will be used through both construction and operation activities. Effluent discharges will be made to the Gömü Creek, provided that a relevant discharge permit is obtained by HEMA.

### 2.5.8 Labor Requirements

The workforce requirement during the construction phase of the port project is anticipated to be approximately 100 people. During the operation phase, a total of 65 people are planned to be employed, consisting of 17 white-collar and 48 blue-collar employees. The employment administrative and operational structure for the HEMA port operations is provided in Table 2-26 below.

Construction and operation workforce will be supplied locally to the extent possible. Appropriate pre-fabricated facilities will be provided to those employees who need onsite accommodation. The existing infirmary of HEMA (which is located at Gömü Shaft-1 site) will be utilized for health care needs of the workforce. Further details and conditions pertinent to management of port project labor are provided in *Chapter 16: Labor and Working Conditions*.

Table 2-26: HEMA port structure of employment

Administrative structure		Operational structure	
Position	Number of employees	Position	Number of employees
General manager	1	Crane operator	12
Assistant manager – Operation	1	Conveyor operator	5
Assistant manager – Technical	1	Weigher	2
Engineer	4	Tally clerk	3
Pilot	1	Rigger	2
Technician	5	Signalman	2
Accounting/office	2	Loading/unloading worker	10
Secretary	1	Maintenance and repair worker	4
Security	2	Driver	2
		Fire-fighter	2
		Security	4
TOTAL	17	TOTAL	48

Source: HEMA Port (Reclamation Area and Quay) Project Feasibility Report by 2ER, June 2012

### 2.6 Road Transportation

As noted earlier, as of late 2013, works for mining of shallow coals has been started near Shaft-1. The extracted coal will be transported to Bartın Cement Plant by road transportation. On the other hand, coal extraction from the shafts is proposed to be initiated late 2015. The processed coal is proposed to be shipped to Çatalağzı Thermal Plant and Eren Thermal Plant in Zonguldak through the HEMA port to be constructed, and continued to be overlanded to Bartın Cement Plant.

Within the scope of the Project, a transportation assessment study was undertaken by Bogazici Proje Mühendislik Planlama Ltd. (Bogazici) and the results were presented in the report titled "Transportation Survey and Evaluation Study for Amasra HEMA Coal Mines" dated June 2012. This study also involved development of a Traffic Management Plan for the Project. The detailed information is given in *Chapter 12: Road Transportation*.

### 3.0 INSTITUTIONAL AND REGULATORY FRAMEWORK

This chapter summarizes the institutional and regulatory framework under which the Project will be developed and implemented.

#### 3.1 Turkish Institutional Framework

The key central, provincial and local governmental authorities relevant to the development and implementation of the Project are described in this section.

##### 3.1.1 Central Government Ministries

The main government ministries with an interest in the Project are as follows:

- Ministry of Energy and Natural Resources
- Ministry of Environment and Urban Planning
- Ministry of Forestry and Water Works
- Ministry of Labor and Social Security
- Ministry of Culture and Tourism

The responsibility and authority of the municipalities are briefly discussed below:

##### *Ministry of Energy and Natural Resources*

The Ministry of Energy and Natural Resources defines targets and policies related to energy and natural resources. The Ministry ensures that energy and natural resources are researched, developed, generated and consumed in accordance with established national targets and policies. The Ministry cooperates with respective Governorates for monitoring and supervision of energy related activities. The Ministry consists of attached, related, and affiliated corporations including the following:

- *General Directorate of Mineral Research and Exploration (MTA)*: MTA was established with the aim of conducting scientific and technological research on mineral exploration and geology. MTA carries out geological research at sea and on land to explore natural resources, to make use of land, to find out energy raw materials and new ore deposits. MTA provides effective use of energy sources performing scientific research.
- *General Directorate of Turkish Coal Enterprises (TKİ)*: The purpose of the institution is (i) to efficiently and sustainably explore, produce, assess and make use of energy raw materials such as lignite, bituminous schist, and asphaltite in accordance with the general energy policy of the government, considering environmental factors and using scientific and technological methods; and (ii) to supply energy demand of the country.
- *General Directorate of the Turkish Hard Coal Enterprises (TTK)*: The main purpose of the TTK is to assess hard coal and other mine reserves within the hard coal basin through preparation of exploration plans, projects and programmes. TTK basically constructs and operates all kinds of aboveground and underground social and industrial facilities to produce hard coal and other mines in the hard coal basin; imports and exports hard coal and other mines in the hard coal basin; operates hard coal mine and other mines in the



---

hard coal basin; undertakes all kinds of transportation and shipment (including land and sea) related to mining activities.

#### *Ministry of Environment and Urban Planning*

The Ministry of Environment and Urban Planning (MEUP) is made up of several directorates, including the following:

- *General Directorate of Environmental Impact Assessment (EIA), Permitting and Auditing* organizes the procedures of EIA and follow-up in coordination with Governorship structures at the local level.
- *General Directorate of Environmental Management* is the primary authority in environmental protection and monitoring procedures, holding the authority for assessment, supervision, and sanctioning in coordination with Governorship structures at the local level.
- *General Directorate of Spatial Planning* identifies the procedures and guidelines related to the preparation of all kinds of physical spatial development plans and environmental management plans in all scales; approves these plans and ensures that those plans are applied and monitored.
- *General Directorate of Natural Assets Protection* is responsible for identifying and managing natural assets (except movable ones, natural archeological sites and the related protection areas).
- *Provincial Environment and Urban Planning Directorates* represent the Ministry within each Governorship and form part of the Provincial Administration. They act in accordance with the Ministry's and the Governorship's activities with regard to environmental issues.

#### *Ministry of Forestry and Water Works*

The Ministry of Forestry and Water Works is made up of directorates including General Directorate of Nature Protection and Natural Parks, General Directorate of Water Management and General Directorate of Combating Erosion and Desertification. The Ministry has several affiliated institutions which include State Hydraulic Works (DSI), State Meteorological Works (DMI) and Turkish Water Institute. The Ministry is responsible of:

- protection, improvement, operation, rehabilitation and maintenance of forest areas; combating desertification and erosion; reforestation and pasture improvement on forestry,
- nature conservation and designation of protected areas; to protect, manage, improve, operate (or having them operated) national parks, nature parks, nature monuments, nature reserve area, wetlands, biological diversity and to protect wildlife,
- conservation and sustainable use of water resources,
- policies and strategies related with monitoring meteorological events and taking relevant measures.

#### *Ministry of Labor and Social Security*

Under the organization of Ministry of Labor and Social Security, there are several divisions which are responsible from occupational health and safety including:

- *General Directorate of Occupational Health and Safety* defines standards of health and safety and coordinates all aspects associated with occupational health and safety.
- *Labor Inspection Board* functions through its labour inspectors, and is responsible of monitoring all activities related to health and safety at the workplace and reporting to the Ministry.
- *Regional Labor Directorates* are ministerial agencies at regional level, conducting monitoring and enforcement of labor law, particularly occupational health and safety.

#### *Ministry of Culture and Tourism*

The Ministry of Culture and Tourism is the responsible body for protection of cultural heritage in Turkey at the national level. As part of the Ministry, the High Commission for the Protection of Cultural Assets is responsible for protecting and restoring the immovable cultural and natural assets. There are also Cultural Assets Protection Regional Boards at regions defined by the Ministry of Culture and Tourism, which are responsible for the protection of cultural heritage within their respective jurisdictions.

#### **3.1.2 Provincial Administration (Bartın Province)**

The highest authority at the provincial level is the Governor, who is directly responsible to the Ministry of Internal Affairs. Governors represent central government (i.e. the Council of Ministers) at the provincial level. Provincial directorates represent their respective ministries at provincial level and form the Provincial Administration under the authority of the Governor.

#### **3.1.3 Local Administration (Amasra District)**

Mayors and Muhtars are the heads of urban (over 7,000 inhabitants) and rural (over 8,000 inhabitants) settlements, respectively. A Mayor is the head of the municipal organization (Municipal Assembly and Municipal Council) and represents the municipality. In urban areas, each neighbourhood also has a Muhtar (neighborhood headman). Both Mayor and Muhtar are elected officials.

### **3.2 Turkish Regulatory Framework**

#### **3.2.1 Turkish Legal Framework**

The legal framework in Turkey is governed by the Turkish hierarchy of norms, which defines the different categories of Parliamentary Act and controls legal precedence in cases of any conflict.

All parliamentary acts have to comply with Constitutional provisions and the constitutionality of these acts can only be contested at the Constitutional Court (*Anayasa Mahkemesi*). Parliamentary Acts are made up of Code Law (*Kanun*) and Decree Law (*Kanun Hukmunde Kararname*). Code Law forms the backbone of the Turkish legal system and is the fundamental reference point for all courts. Decree Laws are legislation prepared by the Council of Ministers and authorized by the Parliament.

Public administrative bodies, such as Ministries, are responsible for the execution of Parliamentary Acts and as such have the authority to develop secondary legislation to ensure implementation of these Acts. Secondary law includes:

- By-laws (*Tuzuk*): Ministries (and in practice the Council of Ministers) are entitled to issue decrees. These regulatory acts are examined by the Council of State (*Danistay*) before they are issued.
- Regulations (*Yonetmelik*): These are issued by Ministries as well as other public bodies with authority of execution. Regulations have to be in compliance with the relevant decrees. Even though they occupy a lower grade than Decrees in the hierarchy of norms, they are usually substituted for Decrees and tend to form the bulk of Turkish legislative documents.
- Circular orders (*Genelge*) and Communiqués (*Tebliğ*). These are legislative documents issued by administrative bodies to ensure implementation of parliamentary acts. They are considered minor legislation, though prominent in certain fields.

### **3.2.2 Applicable Turkish Environmental, Health, Safety and Social Legislation**

The key provisions of Environmental, Health, Safety and Social (EHSS) legislation considered relevant to the Project are summarized in Table 1 of Annex C in tabular format. The key permit requirements for the Project are indicated in the table along with the relevant provisions.

#### *Key Applicable Laws on Environmental, Health, Safety and Social Issues*

The current environmental legal policy framework of Turkey is built on the *Environmental Law* (Law no. 2872). This law provides a legal framework for many regulations scattered throughout the Turkish legislation that seek to clarify and elaborate its intentions, including the Environmental Impact Assessment Regulation.

Labor, health and safety issues are collectively ruled by the *Labor Law* (Law No. 4857), *Occupational Health and Safety Law* (Law No. 6331) and associated regulations.

### **3.2.3 International Conventions Ratified by Turkey that are Relevant to the Project**

Turkey has ratified several international conventions and agreements with respect to environmental conservation. Those conventions and agreements that could have relevance to the Project are listed below:

- Kyoto Protocol to the United Nations Framework Convention on Climate Change, Kyoto (1997) (Turkey made the Ratification Accession on 28 May 2009 and it entered into force 26 August 2009. Turkey is party to the United Nations Framework Convention on Climate Change)
- Vienna Convention for the Protection of Ozone Layer (1985) and the Montreal Protocol on Substances that Deplete the Ozone Layer (1987)
- Bern Convention on the Conservation of European Wild life and Natural Habitats (1976)
- CITES Convention on Trade in Endangered Species of Wild Flora and Fauna (1975)
- Convention on Biodiversity - Biological Diversity (1992)
- MARPOL, International Convention for the Prevention of Pollution from Ships (1973)
- Bucharest Convention on the Protection of the Black Sea against Pollution (1992)

### 3.3 International Requirements

Hattat Enerji ve Maden Ticaret A.S. (HEMA) is seeking financing from financial institutions to fund the development of the Project. It has been agreed with HEMA that the ESIA report will be prepared to comply with the requirements of Equator Principles II (June 2006) and International Finance Corporation’s (IFC) Performance Standards (PSs) on Social and Environmental Sustainability (dated 1 January 2012). It should be noted that Equator Principles II also refer to the applicability of the IFC PSs for assessment of the projects.

#### 3.3.1. Equator Principles II

The Equator Principles (EPs) is a risk management framework, adopted by financial institutions, for determining, assessing and managing environmental and social risk in projects and is primarily intended to provide a minimum standard for due diligence to support responsible risk decision-making.

##### *Equator Principles II (dated June 2006)*

- Principle 1: Review and Categorisation
- Principle 2: Social and Environmental Assessment
- Principle 3: Applicable Social and Environmental Standards
- Principle 4: Action Plan and Management System
- Principle 5: Consultation and Disclosure
- Principle 6: Grievance Mechanism
- Principle 7: Independent Review
- Principle 8: Covenants
- Principle 9: Independent Monitoring and Reporting
- Principle 10: EPFI Reporting

#### 3.3.2. IFC Performance Standards

IFC Performance standards (PSs) are used to evaluate the projects funding through the IFC. The aim of these international standards is to identify and take necessary actions associated with major infrastructure development projects which are considered and managed by proponents in line with international good practice.

##### *IFC Performance Standards (dated 1 January 2012)*

- PS 1: Social and Environmental Assessment and Management Systems
- PS 2: Labour and Working Conditions
- PS 3: Pollution Prevention and Abatement
- PS 4: Community Health, Safety and Security
- PS 5: Land Acquisition and Involuntary Resettlement
- PS 6: Biodiversity Conservation and Sustainable Natural Resource Management
- PS 7: Indigenous Peoples
- PS 8: Cultural Heritage

IFC PS 1 establish the importance of (i) integrated assessment to identify the environmental and social impacts, risks, and opportunities of projects; (ii) effective community engagement through disclosure of project-related information and consultation with local communities on matters that directly affect them; and (iii) the client’s management of environmental and social performance throughout the life of the project. IFC PS 2 through 8 provide guidance on particular topic areas that maybe relevant to an assessment, such as biodiversity conservation, resettlement or cultural

heritage issues. The applicable IFC PSs are discussed in *Chapter 4: Scope of the ESIA, Prior Investigations and Engagement Activities*.

### 3.3.3. IFC Environmental, Health and Safety Guidelines

The EHS Guidelines are technical reference for full and detailed justification and designed to support actions on avoiding, minimizing and controlling the impacts during construction, operation, and decommissioning phase of the project. The General EHS Guidelines including the environmental, health and safety issues which are applicable for all industries are given as follows:

#### **IFC EHS Guidelines**

<p>1 Environmental</p> <ul style="list-style-type: none"> <li>1.1 Air Emissions and Ambient Air Quality</li> <li>1.2 Energy Conservation</li> <li>1.3 Wastewater and Ambient Water Quality</li> <li>1.4 Water Conservation</li> <li>1.5 Hazardous Materials Management</li> <li>1.6 Waste Management</li> <li>1.7 Noise</li> <li>1.8 Contaminated Land</li> </ul> <p>2. Occupational Health and Safety 59</p> <ul style="list-style-type: none"> <li>2.1 General Facility Design and Operation</li> <li>2.2 Communication and Training</li> <li>2.3 Physical Hazards</li> <li>2.4 Chemical Hazards</li> <li>2.5 Biological Hazards</li> <li>2.6 Radiological Hazards</li> <li>2.7 Personal Protective Equipment (PPE)</li> <li>2.8 Special Hazard Environments</li> <li>2.9 Monitoring</li> </ul> <p>3. Community Health and Safety</p> <ul style="list-style-type: none"> <li>3.1 Water Quality and Availability</li> <li>3.2 Structural Safety of Project Infrastructure</li> <li>3.3 Life and Fire Safety (L&amp;FS)</li> <li>3.4 Traffic Safety</li> <li>3.5 Transport of Hazardous Materials</li> <li>3.6 Disease Prevention</li> <li>3.7 Emergency Preparedness and Response</li> </ul> <p>4. Construction and Decommissioning</p> <ul style="list-style-type: none"> <li>4.1 Environment</li> <li>4.2 Occupational Health &amp; Safety</li> <li>4.3 Community Health &amp; Safety</li> </ul>
---

In addition to the IFC PSs, the following sector specific guidelines will also be applicable for the Project:

- IFC Performance Standards on Social and Environmental Sustainability (January 2012)
- IFC General Environmental, Health and Safety Guidelines (30 April 2007)
- Environmental, Health and Safety Guidelines for Mining (10 December 2007)
- Environmental, Health and Safety Guidelines for Waste Management Facilities (10 December 2007)

- Environmental, Health, and Safety Guidelines for Ports, Harbors, and Terminals (30 April 2007)

### **3.4. Comparison of Turkish and International Environmental Thresholds**

Comparison of the Turkish and international environmental thresholds is summarized in Table 2, Table 3, Table 4 and Table 5 of Annex C.

## 4.0 SCOPE OF THE ESIA, PRIOR INVESTIGATIONS AND ENGAGEMENT ACTIVITIES

### 4.1 Overview

Scoping is an important preliminary step in an ESIA process that identifies the key issues to be addressed in the ESIA study. Scoping allows defining which relevant issues should be addressed in the assessment and which issues are of little or no relevance to the Project. In this respect, a scoping study has been carried out for the Project to comply with the requirements of the Equator Principles II (June 2006) which refers to the applicability of IFC PSs. In addition to these standards, IFC General EHS Guidelines and IFC EHS Guidelines for Mining and IFC Environmental, Health and Safety Guidelines for Ports, Harbors and Terminals were taken into account during the scoping study.

The scoping study was performed with the following aspects in accordance with IFC PS1:

- environmental and social risks and impacts of the Project including labor, and health and safety of the workers and the community,
- key stages of the Project including construction and operation, and for accidents and emergencies,
- all elements of the Project (including shaft areas, spoil dumpsites, coal washing plants, port, conveyor belt system and other infrastructure and activities associated with the Project)
- applicable laws and regulations,
- cumulative impacts from further planned development of the Project or any other existing or planned developments, as appropriate.

An ESIA scoping report has been issued in December 2012 which was based on the above mentioned international standards, review of readily available information, reconnaissance site visits conducted by the ESIA team and experts.

#### *Categorization of the Project*

International lenders evaluate projects according to their category based on the scale and nature of potential impacts and risks. Projects are categorized as follows:

- Category A: Projects with potential significant adverse social or environmental impacts that are diverse, irreversible or unprecedented;
- Category B: Projects with potential limited adverse social or environmental impacts that are few in number, generally site-specific, largely reversible and readily addressed through mitigation measures; and
- Category C: Projects with minimal or no social or environmental impacts.

The rest of this chapter presents the results of scoping, prior investigations related to the project and stakeholder engagement activities undertaken to date.

### 4.2 Scoping Results

The following topics were considered during the scoping study:

- Air quality and climatic factors

- 
- Noise and vibration
  - Geology, soils and groundwater
  - Land use
  - Wastewater and waste management
  - Material resources
  - Terrestrial and marine ecology
  - Marine environment
  - Surface water
  - Cultural heritage
  - Visual impacts
  - Traffic and transport
  - Socio-economic impacts
  - Workers health and safety
  - Community health, safety and security

Potential impacts/sources, proposed scope for the ESIA and examples of mitigation measures have been identified for each topic given above. Based on the results of the scoping study, the following potential environmental and social impacts have been identified as key issues:

- **Air quality:** Impacts may occur during underground development works, aboveground construction works, as a result of dust and exhaust emissions caused by construction activities, transportation of construction materials and resources, stockpiling of the excavated soils in the Project area, transport of vehicles, unpaved surfaces, and ancillary facilities. The operational phase impacts include emissions from transportation of the coal, movement of the conveyor, coal washing operations, engines of the ships coming to the port, exhaust air from heating, mine ventilation systems, methane recovery system, fugitive emissions released from the shafts and coal storage areas such as H<sub>2</sub>S, CO<sub>2</sub>, SO<sub>2</sub>, CO etc. and emissions related to the power generation. Environmental impacts of the project on air quality will be assessed in *Chapter 10: Air Quality*.
- **Noise and vibration:** The Project has the potential to cause noise during construction by rock extraction equipments, working vehicles and construction traffic which may affect nearby residential areas. Potential noise during operation will be related to ventilation system, the increase in road traffic, use of the conveyor and container handling equipment in the port, and operation of coal washing plant. Other than that, vibration may be caused by the exploration drilling activities. Noise generation and impacts of the Project will be assessed in *Chapter 11: Noise*.
- **Land Use:** The Project includes three separate mine shafts, spoil dumpsites, sloping activities, a port; with accommodation areas for 581 employees. Therefore, the Project requires the occupation of a large area. Additionally, there are 11 parcels requested to be expropriated by HEMA and permits from several authorities are required in order to use the specified lands. Details of the land use will be discussed in *Chapter 5: Land Use and Zoning* and also in *Chapter 6: Geology, Soils and Contaminated Land*.
- **Wastewater:** Drinking and potable water will be required for usage by the staff and for cleaning of the equipments during construction and operation phases and domestic



wastewater will be generated as a result. In addition, water will be used in mining activities and therefore, industrial wastewater will be generated in the shafts. Potential impacts also include sediment flow due to erosion, poorly managed drainage works and release of contaminated water from maintenance and spoil dumpsite areas. The current situation, impacts and assessments related to water use will be explained in *Chapter 7: Hydrology and Hydrogeology* and also in *Chapter 8: Material Resources and Waste Management*.

**Waste management:** There is a waste generation in the Project site, including excavated soils and rocks resulting from the shaft sinking and driving of gateways, solid wastes, construction wastes (such as steel, cables), hazardous wastes (such as waste oil, oily rags) and medical waste originated from the infirmary of the camp site which requires disposal. Solid waste produced at the construction sites and labor camp site during the construction phase of the Project can be further classified as (i) domestic solid waste, (ii) construction wastes, (iii) packaging wastes and (iv) waste rock. Domestic solid wastes and packaging wastes is being produced by the staff at both the labor camp sites and the construction sites. Construction wastes, to be generated as a result of construction works of the aboveground structures, coal washing plants and the port, are expected as cables, copper, empty containers of various sizes, steel etc.

After the coal production initiates, coal washing plants will be operated in order to increase the calorific value of the coal and as a result of this activity, spoil waste will be generated during the life of the Project which might cause soil, water and groundwater pollution if not collected, stored and disposed properly. Therefore, this waste stream will be handled in accordance with the relevant national and international legislation. Waste management will be assessed in *Chapter 8: Material Resources and Waste Management*.

- **Cultural heritage:** Archaeological surveys were conducted during construction and installation of the current facilities and cultural features were identified in the Project area. The ESIA includes a desktop study and a site survey to identify archaeological sites close to the mine areas and in the vicinity that may be present on the transfer roads which are explained in *Chapter 17: Cultural Heritage*.
- **Traffic and transport:** The Project is likely to have the potential to result in a traffic increase in local roads used for the transportation of the coal to Bartın Cement Factory during operation, until the construction of the port is finalized. Use of the village roads by heavy trucks may need specific management measures. The issue will be further analyzed in *Chapter 12: Road Transportation*.
- **Socio-economic impacts:** The Project will create employment opportunities and may affect positively the local businesses during construction and operation phases. HEMA has cooperated with the Chinese DATONG firm and employed foreign workers for installation of the mine shafts. During these works, Chinese mine technicians and workers have been employed and will continue to be employed in future works. It is expected that some workers would bring along their families since long-term job opportunities are offered by the project. Hence, the migration related impacts such as social conflicts is an important issues throughout the course of the Project.

Other important issues related to the Project are: (i) with the increased population of the region, the demand for education and health facilities will increase, (ii) the port construction activities might generate impacts on the current fishing activities of local fisherman, (iii) the Project may adversely affect the tourism and board housing business

which is very common in Tarlaagzi village as well as in Amasra, (iv) the Project may result in the expropriation of several numbers of lands. The level of possible impacts will be investigated further in *Chapter 14: Socio-economy*.

- **Worker/personnel health and safety:** Activities during construction (i.e. working underground, working with machinery, chemical handling, etc.) carry the risk of injury or damage to workers. Related to operation, impacts may occur through exposure to sudden collapses toxic gases, hazardous materials/waste; and through fire risks related to combustible gas, handling and presence of chemicals and flammable substances. In *Chapter 16: Labour and Working Conditions* the relevant issues will be assessed.
- **Community health, safety and security:** There will be dust, noise and vibration generation during construction activities which may affect nearby communities. Moreover, management of water sources and pollution is an important issue around the mine sites. Indirect effects such as population increase may result in water scarcity as well as the possible reduction of groundwater availability due to mining operations. Other than that, minor changes in soil grade and insignificant impact on settlements and structures may occur as a result of subsidence.

The security during construction is another aspect considering the potential for injuries/accidents to people as a result of unauthorized access to the construction site. Also, new people coming to the region can further affect the local communities especially if separate ethnic groups or nationalities are of matter and due to in-migration may further indirectly affect the injury rates; the influx of large groups of male workers may occasionally cause social disturbance, namely violence or sexual assault. Impacts and mitigations will be explained in *Chapter 15: Community Health and Safety*.

Due to its physical conditions, concurrent transportation is not possible at several locations of the Gomu-Tarlaagzi Village Road and some parts are challenging for heavy trucks due to the slope instability. Furthermore, Amasra-Bartın route has several inclined and curved sections in addition to defects of the ground covering. Therefore, a comprehensive Traffic Management Plan including necessary precautions seems necessary to avoid a critical incident related to road traffic. Impacts and mitigations will be explained in *Chapter 12: Road Transportation*.

All the related topics that are considered during the scoping are also discussed in relevant chapters of the ESIA.

### 4.3 Applicable IFC PSs

Based on the results of the scoping study and subsequent site investigations, those IFC PSs that are envisaged to be triggered by the Project are presented in Table 4-1:

Table 4-1: Applicable IFC PSs

IFC PS	Applicability	Notes
PS 1: Social and Environmental Assessment and Management Systems	Yes	In order to meet the requirements of the international lenders, there is a need to identify and evaluate the potential environmental and social impacts of the Project and to identify relevant mitigation measures, which is the scope of this ESIA study. The ESIA study included engagement with stakeholders which is also required by IFC PS1.
PS 2: Labour and Working Conditions	Yes	The Project is required to establish and maintain a sound worker-management relationship through compliance with national labor, occupational health and safety legislation and following of international guidelines on these issues.
PS 3: Pollution Prevention and Abatement	Yes	The Project is required to identify and implement necessary pollution prevention and abatement measures for the protection of the environment and the people.
PS 4: Community Health, Safety and Security	Yes	The Project is required to identify risks and potential impacts to the health and safety of the communities by the project activities, and to establish preventative measures to address them in a manner commensurate with the identified risks and impacts.
PS 5: Land Acquisition and Involuntary Resettlement	Yes	Expropriation and/or economic displacement may occur related to the Project. The operational rights of Amasra Field with royalty method were transferred to HEMA for 20 years with a contract signed between HEMA and Turkish Hard Coal Enterprises (TTK) on April 15, 2005. However, there are 11 parcels which have requested to be expropriated by HEMA. Additionally, there are 60 parcels were bought dually by HEMA.
PS 6: Biodiversity Conservation and Sustainable Natural Resource Management	Yes	An ecological walkover survey and literature studies have been conducted by flora and fauna experts. Flora and fauna species were evaluated according to international guidelines. Local endemic flora species and fauna species classified under vulnerable category were observed at the site.
PS 7: Indigenous Peoples	No	PS7 is not applicable as no indigenous peoples were found to inhabit the Project area and/or the surroundings.
PS 8: Cultural Heritage	Yes	Amasra is an ancient settlement and there are many cultural assets spread around the city center. Therefore, there is potential for archaeological importance at the Project area.

#### 4.4 Prior Investigations

As mentioned in *Chapter 1: Introduction*, the underground Hard Coal Mine Project (within Amasra B field) was exempt from the Turkish EIA Regulation valid at the time (Official Gazette date/no: 16.12.2003/25318) based on the condition that the Project obtained its operation license before 07.02.1993 (enactment date of the first EIA Regulation in Turkey) as described in the Temporary Article 3 of the mentioned regulation. However, other components of the Project are still required to prepare Environmental Impact Assessment studies (EIA) or Project Introduction File (PIF)

depending on the context of the project, pursuant to the Turkish Environmental Impact Assessment (EIA) Regulation valid on the application dates of the projects.

EIA studies conducted for the different components of the Project are explained in the following sections.

#### **4.4.1 Project Introduction File (PIF) for the HEMA Coal Washing Plants**

The coal to be extracted from Fields A and B has lower calorific value than required by the market. In order to enrich the extracted coal, two coal washing plants will be constructed with 2x500 tonnes/h (TPH) (Amasra Coal Washing Plant, herein referred as ACWP to be constructed on a land with the area of 8000 m<sup>2</sup>) and 200 TPH capacity (Shallow Coal Washing Plant, herein referred as SCWP to be constructed on a land with the area of 900 m<sup>2</sup>), located near Shaft-1 and near the surface inclined gallery entrance, respectively. Coal hauled to surface will be processed in the plants in order to increase the calorific value of the coal by mechanical removal of impurities such as rock, middlings, minerals, ash and contamination to meet the market demand.

A Project Introduction File was prepared for the Ministry of Environment and Urban Planning by DOKAY-CED Environmental Engineering Ltd. under the scope of the Environmental Impact Assessment Regulation valid then (Official Gazette date/no: 02.10.2013/28784). According to the regulation, coal enrichment facilities are included in Annex-2 (Projects which are subject to Selection-Elimination Criteria).

The Project sites for the coal washing plants is in Amasra district, Bartın. The plants will be located on the 3.1 kilometers northeast of Amasra district center, 577 metres northesat of Gomu Village and 1050 metres southwest of Tarlaagzi Village. Within the scope of the Project, there are two coal washing plants, two coal storage areas and Spoil Dumpsite 1, Spoil Dumpsite 2 and Spoil Dumpsite 3. No additional construction sites, worker accommodation facilities or water treatment plants are included in the project.

Some parts of the project site are designated as forestlands, therefore, necessary permissions have to be obtained from Regional Directorate of Forestry according to the Articles 17 and 18 of Forest Law (Official Gazette date/no: 07.07.2012/28346).

The main project coal will be processed in ACWP with the capacity of 2x500 TPH and the shallow coal to be extracted at an earlier stage will be processed in SCWP with the capacity of 200 TPH to be delivered. Land preparation and installation of the first module of the ACWP with 500 TPH capacity is envisaged to be finalized in 160 days whereas the second module to be finalized in 200 days. On the other hand, SCWP is envisaged to be completed in 75 days. Operation lives of the both plants are projected to be 30 years.

The PIF firstly describes and identifies the features of the project which are mainly the flow process chart, capacities, the technology; use of natural resources; amounts of wastes to be generated and land recreation studies. After that, the project site for the coal washing plants and the baseline conditions of the environment was investigated in details. Lastly, the environmental impacts of the project during both construction and operation phases were assessed and mitigations measured to be undertaken are defined.

Additionally, there are three Spoil Dump Sites defined in the PIF, on the purpose of placing the solid waste generated during the operation of the coal washing plants. It is stated that, the material disposed in these sites will be covered with soil and no holes will be left in order to prevent the formation of any kind of water ponds. It is also undertaken that a site rehabilitation project for Spoil Dump Sites will be prepared and presented to Regional Directorate of Forestry and related local governmental authorities.

The first draft of the PIF was presented to the Ministry of Environment and Urban Planning on January, 2014. "EIA is not required" document for the coal washing plants was obtained on 27.01.2015.

#### **4.4.2 Environmental Impact Assessment of the HEMA Port (Reclamation Area and Quay)**

As mentioned in the previous chapters, HEMA is planning to construct a port (reclamation area and quay) to the east of the existing Tarlaagzi Fishery Port in the coastal part of Tarlaagzi Village for shipment of the coal to be produced.

For the port project, an Environmental Impact Assessment Report was prepared for the Ministry of Environment and Urban Planning by DOKAY-CED Environmental Engineering Ltd.

The Project was presented a reclamation area and a 250-meters-long quay with 2 handling dolphins and a 350-meters-long breakwater, for ships having 30,000 DWT capacity. However, wave transformation and agitation analyses showed a 494-meters-long breakwater is needed at the site. Construction and investigation periods of the project are 24 and 34 months, respectively. The quay is projected to be in operation for 49 years.

The EIA Report consists of the description and aim of the project, details of the project area, baseline conditions and socio-economic characteristics of the area, major environmental impacts of the project and mitigations measures to be undertaken, and lastly the public participation. Within the context of the study, the following analyses were conducted and attached to the EIA report:

- Sanding Potential Analysis Report
- Wave Climate, Wave Transformation and Port Basin Agitation Analyses Report
- Rock Handling, Rock Analysis and Sloping Report
- Baseline Environmental Analyses
- Acoustic Report
- Hydrographic, Oceanographic, Geologic and Geophysical Investigation Report
- Maneuvering Simulation Report
- Long-term Meteorological Report
- Marine Biodiversity Report
- Terrestrial Ecology Report
- Geological & Geotechnical Investigation Report

The first draft of the EIA Report was presented to the Ministry of Environment and Urban Planning on 06.03.2012. The assessment commission of the Ministry determined that some revisions were needed for the report. Third draft of the revised EIA report was accepted to be the final draft according to the Article 12 of the EIA Regulation. After the considerations and inspections of the

---

commission are completed, the final draft EIA report was announced for public consideration on 09.12.2013 and the final presentation was held on 07.01.2014. EIA is currently under approval process. "EAI positive" decision is still pending for the project.

#### **4.5 Stakeholder Engagement Activities during ESIA Study**

A social baseline study was conducted in 2011 by 'PD Anadolu Araştırma' in the five Project-affected settlements (Kum Neighbourhood, Fatih Neighbourhood, Gomu Village, Tarlaagzi Village and Kazpinari Village) between the dates October 5-9, 2011 with a team of six people comprising one team supervisor, one focus group moderator and four interviewers. Settlement level questionnaires were conducted with the headmen of the villages in order to obtain general information about the region. Additionally, focus group discussions were conducted with vulnerable groups such as women, disabled, and elders. Details of the study is further analyzed in *Chapter 14: Socio-Economy*.

Additionally, a 'Social Impact Evaluation Report' is prepared in 2012 by Prof. Dr. Suavi Aydın in order to evaluate the social impacts of the different project activities which are planned to be accomplished and expected to affect the vicinity of Gomu and Tarlaagzi Villages in Amasra County, Bartın Province. For this purpose, a detailed social impact evaluation was carried out in that area and the fishing port located in Tarlaagzi Village.

Other than that, during the EIA studies of the HEMA Port, a public consultation meeting was organized and announced to be held Gomu Village Manison on 24/04/2012; however, because of a mass protest of the public and NGOs, it was decided to be cancelled.

A Stakeholder Engagement Plan (SEP) has been developed by ELC Group for the Project, to help structure a systematic communication with the stakeholders during the ESIA study. Relevant stakeholders were identified including governmental authorities and non-governmental organizations (NGOs) at national, regional and district level, and local communities. In addition to that, within the scope of the ESIA studies, a Stakeholder Communications Plan is prepared by C-Line Public Relations Firm which includes;

- Current Situation
- Risks and Stakeholders
- Compliants of the Stakeholders
- Engagament Methods
- Stakeholder Information Strategy
- Stakeholder List
- Actions to be taken

## 5.0 LAND USE AND ZONING

### 5.1 Scope

This chapter describes the land use and identifies the regional/local zoning plans within the Project area. The land usage and assets mainly include individual agricultural lands (consisting of trees, meadow, hazelnut groves, marginal agricultural land), forestlands, archeological protection zones and residential lands in private ownership with formal rights. The impacts on land use within the Project area are further addressed. The following tasks has been conducted for the land use assessment:

- Identification of existing land uses within the Project area and its surrounding through site visits and aerial photographs,
- Identification of existing expropriation status within the Project and potential changes due to future land uses,
- Review of existing local zoning and regional plans within the Project area,
- Identification of the impacts and mitigation measures with regard to land use and zoning,

The following source of information have been used during the assessment:

- 1/100,000 scale Zonguldak-Bartın-Karabük Planning Zone Environmental Plan (Approval Date: 03.05.2012)
- 1/25,000 scale Bartın and Bartın Coastal Region Sub-Regional Planning Zone Environmental Plan (Approval Date: 10.04.2014)
- Environmental Impact Assessment Report for the Port (Reclamation Area and Quay) prepared by Dokay-ÇED Ltd. (April 2013)
- Project Introduction File for Coal Washing Plant prepared by Dokay-ÇED Ltd. (January 2014)
- Amasra Hard Coal Production Project Report by SRK (October 2013)

The significance criteria for impacts on land use and property has been based on assessment of impact magnitude and the sensitivity receptors for land owners as given below.

Impact Significance Criteria	Description
Not Significant	<ul style="list-style-type: none"> <li>- Temporary use of land which causes insignificant reduction of forestlands or agricultural lands (&lt;10%)</li> <li>- No impacts on livelihood pattern of households</li> </ul>
Minor	<ul style="list-style-type: none"> <li>- Reduction of forestlands or agricultural lands (10%) which leads noticeable change in overall livelihood pattern of households</li> <li>- Land acquisition which does not result in any physical and/or economic displacement of individuals</li> </ul>
Moderate	<ul style="list-style-type: none"> <li>- Reduction of forestlands or agricultural lands (&lt;50%) which results in significant changes of overall livelihood pattern of households</li> <li>- Land acquisition which results in physical and/or economic displacement of individuals</li> </ul>
Major	<ul style="list-style-type: none"> <li>- Large magnitude impact on forestlands or agricultural lands (&gt;50%) which results in irrecoverable change of overall livelihood pattern</li> <li>- Land acquisition which results in involuntary physical and/or economic displacement of individuals</li> </ul>

## 5.2 Land Use Pattern

The Project site is located within the boundaries of Amasra District of Bartın Province which covers an area of 50 km<sup>2</sup> consisting of two sub-fields as Field A and Field B. The operational rights of Amasra Field B were transferred to HEMA for a period of 20 years (The contract duration can be extended for additional 10 year-periods upon request by HEMA), pursuant to the royalty agreement made on April 15, 2005 between the Turkish Hard Coal Enterprise (TTK) and HEMA. The site delivery of the mining license area was realized in May 2006.

The Project is composed of construction of three shafts, surface inclined galleries, two coal washing plants, spoil dumpsites, electrical transmission lines and the port. The development and construction of the mining activities require land clearing for mine as well as process components such as waste dumpsite/storage areas, infrastructure buildings, roads, accommodation facilities, transmission lines, coal processing plants, shafts and access corridors to the mine site. The general view of the project area is represented in Figure 5-1.



Figure 5-1: General view of the Project Components

The shafts are located in the vicinity of Gomu and Tarlaagzi Villages (Shaft-1), Kazpinari Village (Shaft-2) and Amasra District (Shaft-3), each having a diameter of about 8 meters and depths of 700.5, 730.0 and 579.8 meters, respectively. Two coal washing plants are located around Shaft-1 in order to increase the calorific value of the coal. One of the plants (SCWP) is located near the surface inclined gallery and the other one (ACWP) is located near Spoil Dumpsite-1. Moreover, the HEMA Port (reclamation area and quay) project is proposed to be constructed east of Tarlaagzi Fishing Port with the intention of shipment of processed coal to Catalagzi and Eren Thermal Power Plants.



Table 5-1: Distances of the main components of the Project

Component	Distances (m)					
	Tarlaagzi Village	Gomu Village	Kazpinari Village	Amasra District	Tarlaagzi Fishery Port	Nearest House
Shaft-1	1,200	1,100	2,600	4,000	1,000	350
Shaft-2	2,700	3,500	650	5,800	3,100	350
Shaft-3	4,200	2,000	4,000	800	4,000	100
SCWP	1,000	1,375	2,500	4,300	750	60
ACWP	1,400	900	2,600	3,800	1,200	430
Coal Storage-1	1,000	1,200	2,600	4,100	800	113
Spoil Dumpsite-2	1,200	1,200	2,400	4,200	970	240
Coal Storage-2	1,400	800	2,800	3,700	1,000	430
Spoil Dumpsite-1	1,300	560	2,500	3,500	1,200	140
Waste Rock Dumpsite of Shaft-2	2,300	3,000	400	5,400	2,700	160
HEMA Port	1,100	1,400	3,100	4,200	400	400

Mining activities often require access roads for coal transportation and temporary camp sites to provide accommodation for workers which may also result in land clearing. While the construction activities regarding the HEMA port is on-going, coal will be transported via highways. The detailed coal transportation route and its representation are given in *Chapter 12: Road Transportation*. Once the HEMA Port comes into operation, the extracted and processed coal will be sent from Shaft-1 to bulk cargo quay using covered belt conveyor system.

The HEMA port project area is proposed to be constructed east of the existing Tarlaagzi Fishing Port which is expected to come into operation by mid-2017. Since the project area is highly sloped and posing risks associated with the landslides and erosion, slope protection area is intended to be constructed to provide stabilization. The resulting material from the slope protection area will be used as reclamation material. The soil characteristics and erosion impacts and related mitigation measures are presented in *Chapter 6: Geology, Soils and Contaminated Land*.

Based on the review of Google Earth imagery, the agricultural field patterns and forestlands can be described as relatively homogeneous within the Project areas. The agricultural production is limited with private household activities when compared to other parts of the Turkey and parcels are mainly fragmented and scattered between farmer families by inheritance. "Hema Hard Coal Mine Project Social Baseline Survey Report: A Social Baseline Study" was conducted in the Project-affected settlements (Gomu Village, Tarlaagzi Village and Kazpinari Village) in October, 2011. According to the social baseline survey report, 79 household carry out agricultural production mainly including hazelnut and vegetable growing within the subject area.

### 5.2.1 Shaft-1 area

Shaft-1 is located between Tarlaagzi and Gomu Villages, approximately 1,1 km southwest of Gomu Village, 1.2 km east of Tarlaagzi Village. The closest settlement is a house which is located in approximately 350 meters west of Shaft-1. There is an elevation difference approximately 50 m between the house and the Shaft-1 area where the shaft area located at the lower elevation. There is also one other house located on the 450 m east of Shaft-1, which belongs to the Gomu Village. There are nine houses located in a distance of 80 to 140 meters east of the Spoil Dumpsite-1 which belong to the Gomu Village. There is also one house on the north, which is approximately 180 m away from the north of the Spoil Dumpsite-1. Additionally, there is a single house located on the 100 m north of the surface gallery entries (as shown in Photo 5.1 and 5.2). Shaft-1 is located at a

driving distance of approximately 2.6 km to the Amasra-Bartın road which is on the south side of the proposed area. There is a village road crossing the south end of the shaft area, which connects Amasra-Bartın road to Gomü and Tarlaagzi Villages.



Photo 5.1. Nearest House to Surface Galleries      Photo 5.2. Closest Houses to Shaft 1(Gomu)

As it is stated in the Project Introduction File of the coal washing plants, 8,000 m<sup>2</sup> areas is reserved for establishing 500 t/h capacity ACWP and 900 m<sup>2</sup> area is reserved for 200 t/h capacity SCWP. Currently there are two surface inclined gallery entrances located adjacent to the south of planned 200 t/h coal washing plant. Overall view of the Project components around Shaft-1 area is shown in Figure 5-2.

Coal Storage-1 and Spoil Dumpsite-2 will be located adjacent to the surface mine entries and SCWP. Coal Storage-1 will be located on a land with the surface area of 6,400 m<sup>2</sup>. Spoil Dumpsite-2 will be located on a land with the surface area of 7186.60 m<sup>2</sup> and approximately 70,000 m<sup>3</sup> of spoil will be stored here (Figure 5-2).

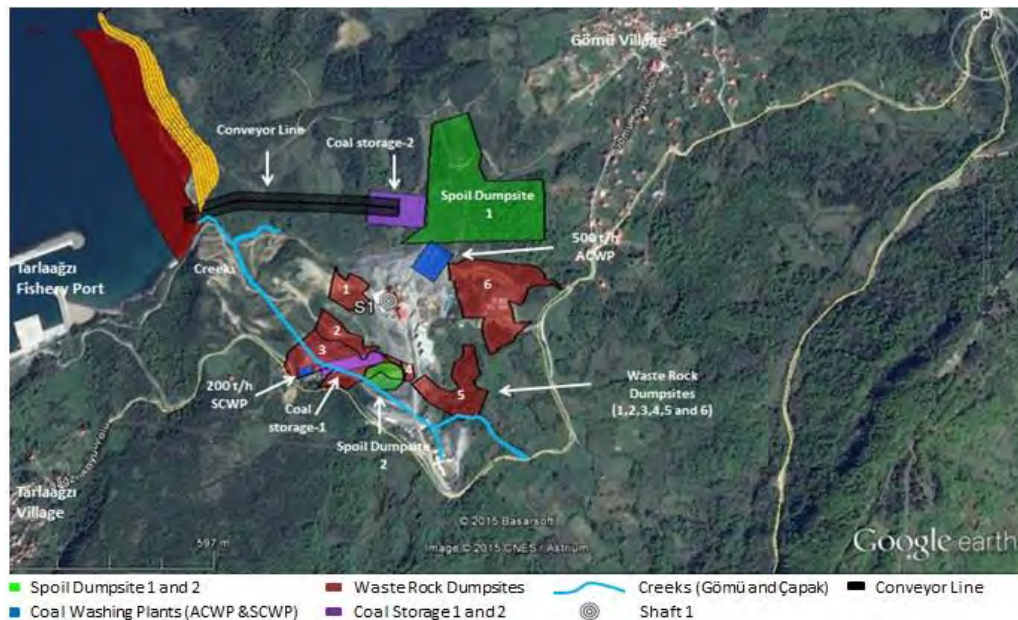

Figure 5-2: Overall view of Project components around Shaft-1 area

Coal Storage-2 and Spoil Dumpsite-1 will be located adjacent to each other at the north of the shaft-1 and will be connected to 500 t/h coal washing plant. Coal Storage-2 will cover a surface area of approximately 16,000 m<sup>2</sup> and there will be a conveyor line to transport the coal from that point

to the Port. The proposed conveyor belt situated in a forested area and covers a surface area of 32,428.90 m<sup>2</sup> of which 25,799.20 m<sup>2</sup> is permitted as forestland and the remaining include the private parcels. The conveyor belt corridor will be of 2 meters width and the distance from Shaft-1 to bulk cargo quay is approximately 1,000 meters. Spoil Dumpsite-1 and soil disposal site will be located on a surface area of approximately 88,465.93 m<sup>2</sup> and 999 m<sup>2</sup>, respectively. It is expected that approximately 3,500,000 m<sup>3</sup> of spoil material will be stored here.

Apart from that, waste rock dumpsites are located in front of the surface mine entries which are currently flattened to be used during gallery opening works and filled by the waste rocks generated from the gallery works. This area was previously a very steep slope extending all the way to seaside and is presently being filled with the waste rock material to ensure slope stability. The waste rock dumpsites are numbered as “1, 2, 3, 4, 5 and 6” (surface area 112,364 m<sup>2</sup>) and represented in Figure 5.3. Currently, HEMA is disposing waste rocks generated during the gallery drivings to the areas numbered as 1, 2, 3 and 4 (surface area 47,801 m<sup>2</sup>).

There are two seasonal creeks called as “Gomu” and “Capak” creeks located within the area of Shaft-1. One of them flows along the south-west of the Shaft-1 and merges with other creek which is coming from the north of the shaft and both flow into the sea within the planned port area as shown in Figure 5-3: . According to the letter obtained from 23<sup>th</sup> Regional Directorate of State Hydraulic Works dated: 20.02.2013/numbered: 97740, stream beds of creeks should be protected from any action related with the disposal of waste materials such as tree branches resulted from the construction activities. Therefore, HEMA took action to preserve the stream bed of Capak Creek either in south entrance of Shaft-1 area and the merging point of two creeks (shown in Photo 5.3). Some parts of Capak Creek was covered with cement culvert in order to prevent any contamination during project activities (Photo 5.4).



Photo 5.3. Merging point of two creeks



Photo 5.4. Capak Creek reclamation

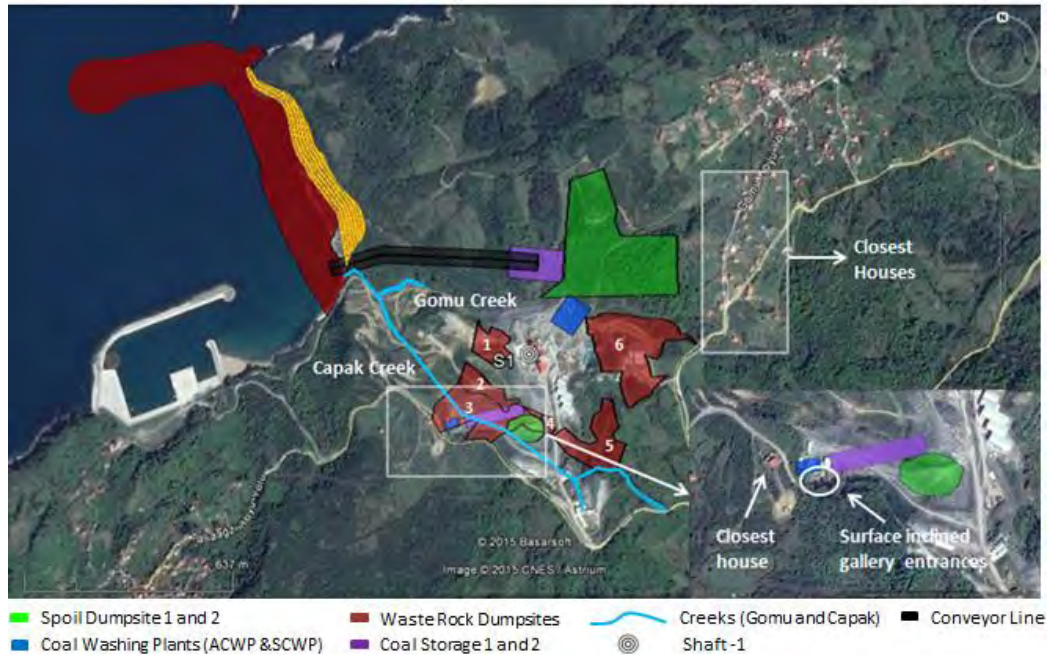

Figure 5-3: Distribution of influenced areas in the vicinity of Shaft-1

Additionally, personnel accommodation areas and social facilities exist within the area. There are four dormitory rooms with 405-bed-capacity of which two of them is available for 248 Chinese workers. There is one dining hall and storage room located within the Shaft-1. Apart from that, dressing rooms and showers, boiler room, water tank and training facility are present in the area. General view of accommodation facilities is shown in Photo 5.5.



Photo 5.5. General view of Shaft-1 area

Furthermore, there is an area on approximately 150 m south of the Spoil Dumpsite-2 which is rented from Amasra Hard Coal Enterprise (ATI). As it is stated by HEMA, there are only some office buildings and car parking area located there.

### 5.2.2 Shaft-2 Area

Shaft-2 is located on approximately 700 m southwest of Kazpinari Village, at driving distances of 850 m to Amasra-Bartın Road and 4.5 km to Bartın-Ankara road. The closest settlement is a house in Kazpinari Village which is located on approximately 170 m east of the Shaft-2. Currently, there are various buildings which have already established Shaft-2 (three dormitory rooms with 150-bed-capacity, an office building, boiling room, two dining hall and a laundry room), however the major

units like the substations and switchgears are planned to be established in future (Photo 5.8). 154 KV and 31.5 KV energy transmission line will be connected to these units and diverted to be distributed to the shafts. Substations will feed 31,5 kV of power to switching stations.

There is an area planned to be used as a waste rock dumpsite which will be located adjacent to the northwest of the Shaft-2. Waste rock dumpsite and soil disposal area will have a surface area of approximately 149,353.50 m<sup>2</sup> and 1004.38 m<sup>2</sup>. The overview of the Project components around the Shaft-2 and the surroundings is represented in Figure 5-4.

There is a branch of Buyukdere Creek passing through the proposed Waste Rock Dumpsite area (shown in Figure 5-4 and Photo 5.6). The Waste Rock Dumpsite is intended to be used for the disposal of the wastes generated during the gallery opening activities.

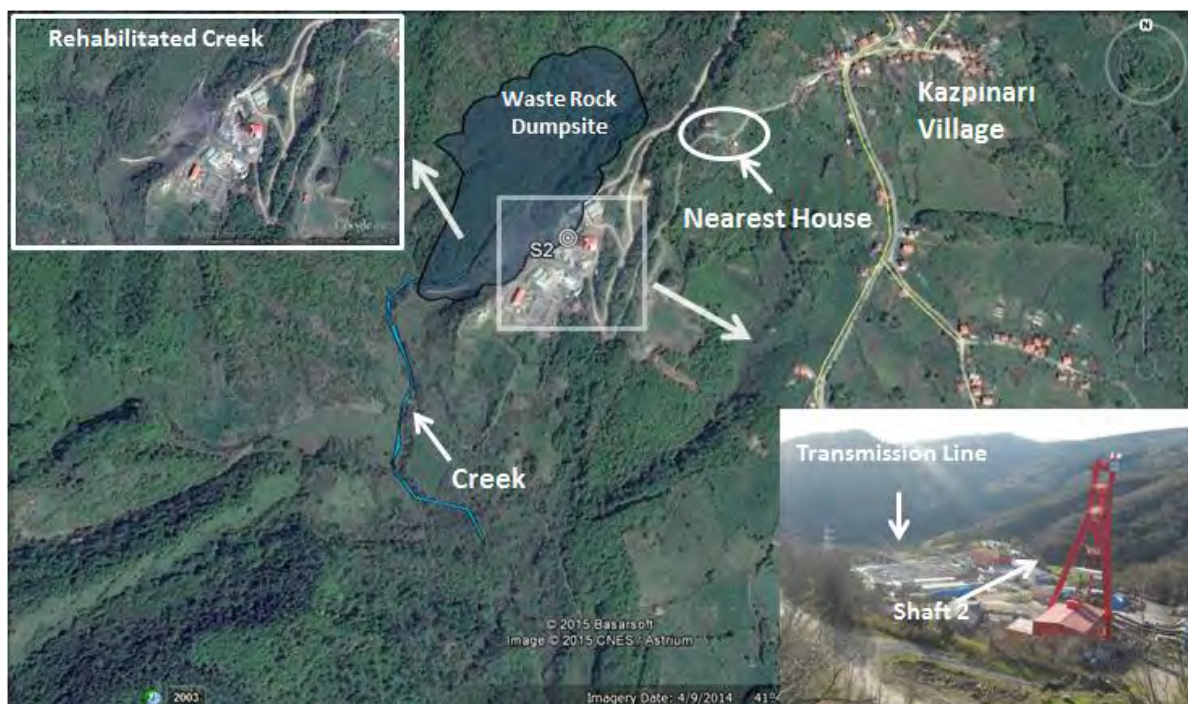

Figure 5-4: Overall view of Shaft-2 area

Since the area in the front of the gallery entrance is steep slope, these materials will act as a filling material. According to the information given by HEMA, some parts of the creek within the proposed dumpsite boundaries are covered with a cement culvert in order to prevent any contamination that may arise from the Project activities. After covering the creek, the excavated waste rocks were filled within the area occupied by HEMA. The current status of the area can be seen from the reference picture Photo 5.6.



Photo 5.6. Reinforced Concrete Culverts for Buyukdere Creek



Photo 5.7. Spoil Dumpsite- in front of the Shaft 2



Photo 5.8. Transmission Line

### 5.2.3 Shaft-3 Area

Shaft-3 is located approximately 800 m south of the Amasra District Center and there are mining facilities belonging to TTK around the shaft. There are three dormitory rooms with 66-bed-capacity, two dining hall and a storage area, a dressing room, an office building and two guesthouses exist in the proposed Shaft-3 area. The mining facility of TTK is approximately 50 m away from Shaft-3 represented in Figure 5-5.



Figure 5-5: Overall view of Project components around Shaft-3 area

The closest settlement is a house which is located on approximately 100 m east to the Shaft-3. There is also a forestland between the shaft and the house. Currently, all units of the Shaft-3 have already established in the area and some buildings/units are established on the north part of the land which rented from TTK. Some illustrative pictures of the Shaft-3 area presented below in Photo 5.9 and 5.10.



Photo 5.9. General View of Shaft-3



Photo 5.10. View of TTK Shaft Area

#### 5.2.4 HEMA Port Area

HEMA Port is planned to be built on a surface area of 163,000 m<sup>2</sup> and involves reclamation works and construction of a breakwater, a quay structure and storage yards. The area within the Port boundaries is currently vacant. Adjacent to the south boundaries of the Port, there are four empty houses whose construction was not completed and abandoned after rough construction (Figure 5-6 and Photo 5.11).

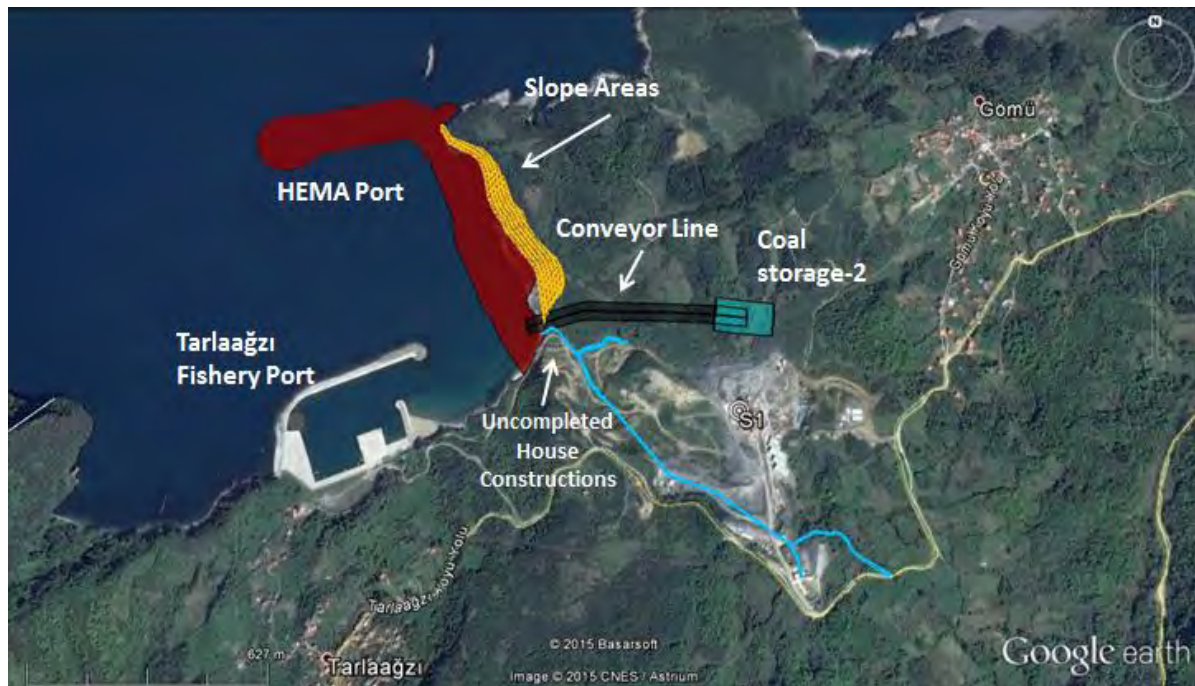

Figure 5-6: Overall view of Project components around HEMA Port area

HEMA port will be constructed to the bay where Tarlaagzi Fishing Port is currently located. There will be a construction of slope area on the east of the proposed HEMA Port area which is to protect the Port from possible landslides and/or rock falls. The Fishing Port is in operation since October 2005 and currently able to serve 120 boats at the same time. It is also possible that the Port to expand its capacity to 190 boats in the future. The nearest house to the port which belongs to Tarlaagzi Village is located approximately 400 m away from the south boundary of the Port area. A conveyor line is planned to be established on the east of the Port area in order to transfer the produced coals. The closest settlement to the conveyor line is a house having an approximate distance of 500 m on south.



Photo 5.11. The Uncompleted House Constructions and HEMA Port Area



## 5.3 Land Ownership

### 5.3.1 Ownership of the Shaft and Port Areas

Currently, the part of the HEMA port which resides in the sea is belongs to the Treasury and as it is stated in the Environmental Impact Assessment Report of HEMA Port, the area will be rented from the General Directorate of National Estate of the Treasury. The remaining land especially behind the slope area defined as the nonregistered forestland. According to the National Environmental Impact Assessment Report, necessary permitting procedure will be applied for permit of usage by applying to 10<sup>th</sup> Regional Bartın District Branch Office of Ministry of Forestry and Water Affairs.

According to the information obtained from HEMA, Shaft-1 area is mainly owned by the HEMA. There is a total of 225,255 m<sup>2</sup> area, consisting 44 parcels, purchased up to now for the construction of the port, shaft and workshop buildings regarding the Project activities. The land reserved for the coal storage and spoil dumpsite includes private parcels and parcels requested for expropriation. The conveyor line is also located within the areas defined as forestland, nonregistered forestland and parcels which planned to be expropriated. The proposed conveyor line (from coal storage area to port) is represented in Figure 5-7 with black dotted line.

All the metes and bounds of SCWP is located within the permitted forestlands. As it is stated in the Project Introduction File for Coal Washing Plant the ACWP area lies on the permitted forestland, located within the boundaries of the Bartın Forestry Department and Amasra Forest sub-District Directorate under authority of the Zonguldak Regional Directorate of Forestry and also on a nonregistered forestland. The total area located on the southwest of Shaft-1 including administrative buildings and a car parking area, which was previously ATİ parcels and rented by HEMA, covering the surface area of 22,740 m<sup>2</sup>.

Table 5-2: Total surface areas and locations of parcels owned by HEMA

Location	Land Type	Surface Area (m <sup>2</sup> )
Shaft-1 (Gomu)	Agricultural Field (38 parcel)	180,392
	Hazelnut Grove (2 parcel)	27,863
	Not known (4 parcel)	17,000
	Total	225,255
Shaft-2 (Kazpinari)	Agricultural Field (8 parcel)	77,979
	Not known (7 parcel)	38,758
	Total	116737
Shaft-3 (Amasra District Center)	Not known	18,810

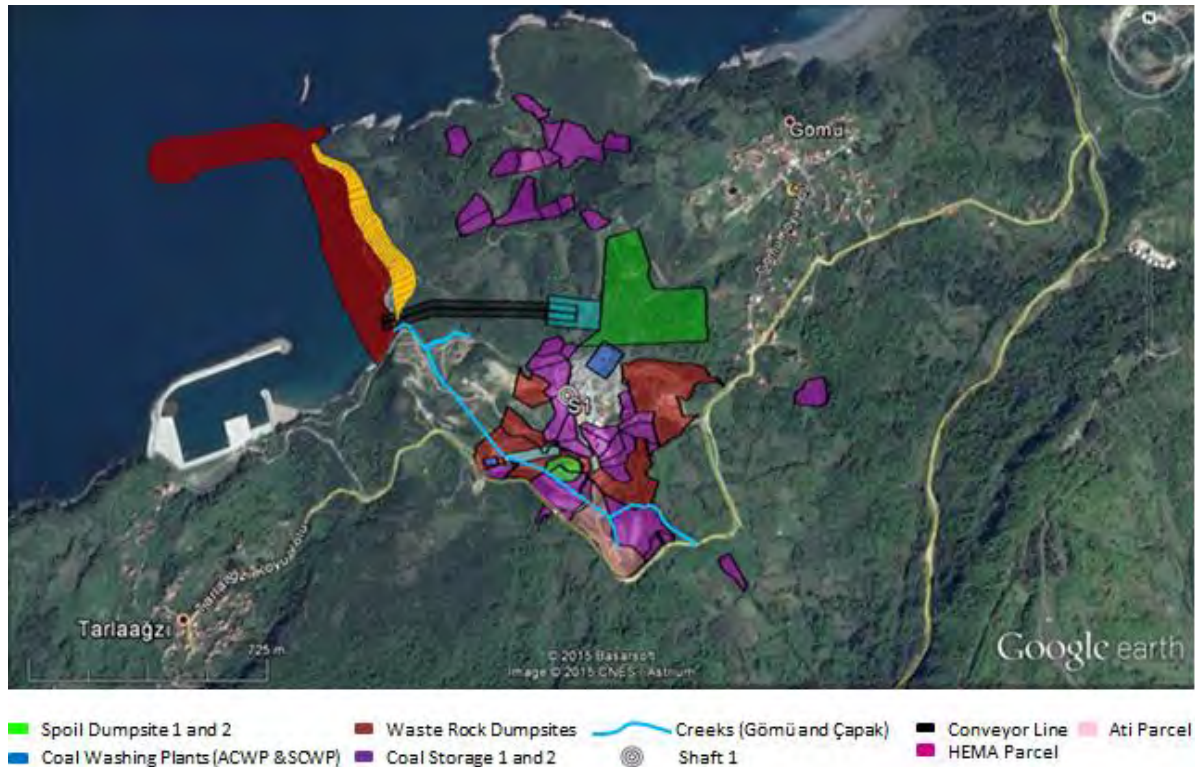

Figure 5-7: The identification of current situation of parcels around Shaft-1 area

According to the information obtained from HEMA, Shaft-2 is located on 15 parcels owned by HEMA, covering a surface area of 116,737 m<sup>2</sup>. HEMA applied for permission from Ministry of Forestry for dumping the waste rock originating from underground construction activities since some part of the area is forestland and the permission is still in progress.

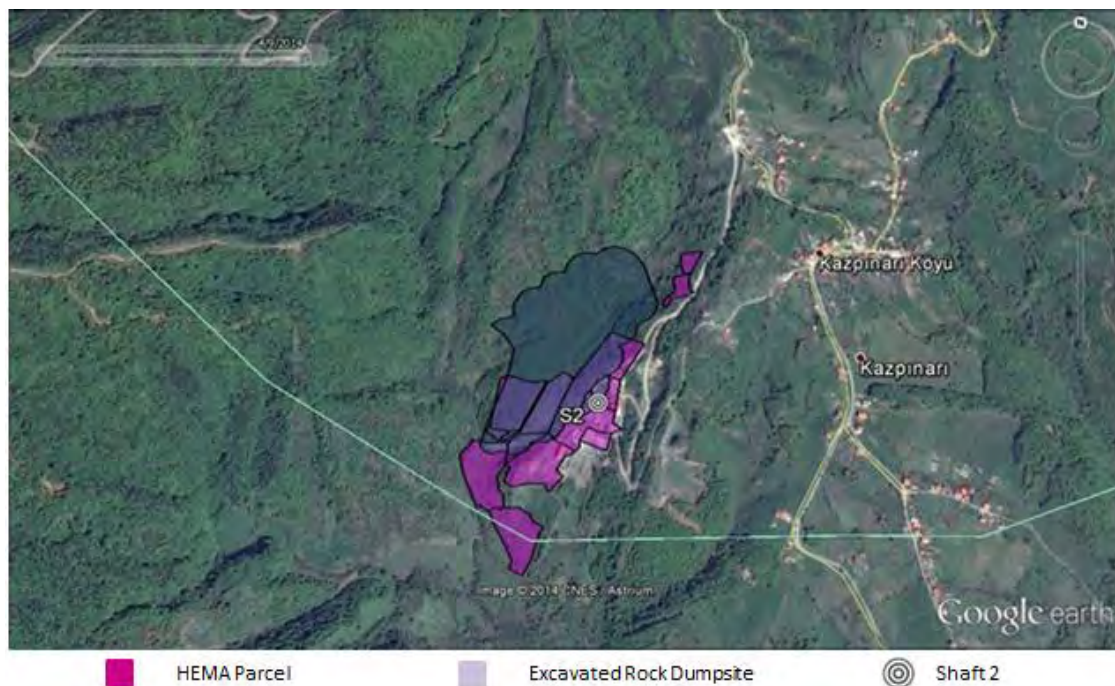

Figure 5-8: The identification of current situation of parcels around Shaft-2 area

The proposed Shaft-3 area is composed of HEMA parcels, ATİ parcels (rented by HEMA) and forestland which belonging to the Treasury. Total area owned by HEMA consisting shaft and workshop buildings is 18,810 m<sup>2</sup>. The areas belonging to ATİ are rented in accordance with the royalty agreement and the total surface area of 11 rented ATİ parcel is 29,455.2 m<sup>2</sup>. As it is seen in the Figure 5-9, buildings in Shaft-3 area are generally located in the parcels owned by HEMA.



Figure 5-9: The identification of current situation of parcels around Shaft-3 area

## 5.4 Expropriations

### 5.4.1 Expropriation Process

Expropriation is regulated by the Expropriation Law (Law No. 2942, amended in 2001 by Law No. 4650). A Declaration of Public Interest is necessary for expropriation of any property and this must be approved by the Governor, unless the development is carried out in accordance with an approved Development Plan or Special Plan or Project approved by the relevant Ministries. In these cases, a simple Declaration will be made indicating that the expropriation process will be initiated by the authorised executive body. Acts of expropriation can only be exercised on immovable assets. In this case, the responsible governmental authority is Turkish Hard Coal Enterprise (TTK) since the royalty agreement for the transfer of the operational rights of Amasra B Field was made with TTK.

Only the legal owners of properties are eligible for compensation. Occupiers (called as *zilyet*) may be eligible in cases when the title deed for the property is not registered and there are no people claiming rights on the property.

Assets which are eligible for compensation include (i) a property or a resource in land, (ii) a plot, and (iii) buildings where these are owned by real persons or legal entities under private law.

---

The expropriation law requires compensation to be paid in cash and in advance of expropriation taking place.

There are a number of steps in the expropriation process as described below.

#### **I – Administrative Procedure:**

- (i) Commencement of expropriation:** The expropriation process commences with the issue of a Declaration of Public Interest by the relevant Ministry and the approval of the Governor (unless the project is already part of an approved plan or project) of the province in which the project is located.
- (ii) Preparation of plans:** The authority undertaking the expropriation must prepare a scaled plan defining the boundaries, surface area and type of each of the assets to be expropriated or on which right of easement to be established.
- (iii) Identification of the property owners:** The authority must define and document the owners of each property being expropriated, or the occupiers in cases where there is no registered title deed. Their addresses must be identified using records kept at the title deed offices, tax offices or civil registry offices, or by means of an external search. Where there are no registration or cadastral records at the title deed or cadastral offices, the authority must apply to the local civil administrator to appoint four experts, two principal and two substitute members, to undertake a land survey of the area. It is understood that all the owners are registered and identified during the expropriation process for the Project.
- (iv) Informing the title deed office about the expropriation decision:** After the expropriation decision is approved, the authority must notify the title deed offices at which the properties subject to expropriation are registered, to place a note on the title deeds for the properties subject to expropriation. If the expropriation does not proceed within 6 months that note must be removed by the title deed office.
- (v) Establishment of Valuation Commission:** A Valuation Commission (Kıymet Takdir Komisyonu) or Commissions must be appointed by the authority carrying out the expropriation, to determine the value of the property. The Commission must comprise at least three individuals working at the authority who will carry out the expropriation.
- (vi) Establishment of Reconciliation Commission:** The authority carrying out the expropriation must also appoint a separate Reconciliation Commission (Uzlaşma Komisyonu) or Commissions, also comprising at least three individuals, to negotiate the amount of compensation and execute and complete the purchase by solving possible disputes on expropriation value.
- (vii) Notifying the owner:** The authority must notify the owner by official registered letter of their intention to acquire the property or to offer a replacement property. At this stage the valuation is not given and there is an opportunity for the owner to agree a price or a suitable replacement property by negotiation.
- (viii) Application to the authority by the owner:** If the owner is willing to sell the property, he (or his authorised representative) can apply to the authority, within fifteen days and

negotiations will be held on a date designated by the Reconciliation Commission. Provided the agreed price or the value of the exchange does not exceed the valuation, a minute is issued and signed by the owner or his representative and the members of the Reconciliation Commission.

- (ix) Payment to the owner:** The authority must prepare the payment within forty five days of the date of the minute, and send a written notification to the owner requesting transfer of the property to the authority at the title deed office on the specified date. When the transfer is complete, the agreed price is paid. The property, resource or right of easement purchased or exchanged by barter method is considered as purchased by expropriation and the owner has no right of appeal against the expropriation or the agreed compensation. The agreement must be reached and any monies paid, before the expropriation can take place.

The articles (v) to (ix) is the purchasing procedure (as described in article 8 of the Expropriation Law) that shall be applied for the expropriation of the properties.

### ***Barter method***

Expropriation Law also envisages another form of payment named 'the barter method' (trampa usulu), in which land of equal value possessed by the State is given to the owner in return for the expropriated property. This process is implemented according to the article 26 of the Expropriation Law. If acceptable to the affected owner, compensation in kind may be provided by the authority by provision of an alternative property not used for public service, to cover all or part of the expropriation value. The value of the replacement property will be determined by the authority's tender commission or by any commission established for the purpose of valuation.

Any difference between the values of original and replacement properties shall be met by the parties in cash. The value of the replacement property must not exceed 120% of the expropriation value.

### ***Compensation Arrangements and Rates***

During the valuation process, the authority will receive reports from experts, institutions and organizations and may, if necessary, use information from the Chamber of Industry and Commerce as well as local real estate agencies.

In cases where expropriation is not achieved by agreement, valuation is performed according to Article 11 of the Expropriation Law. The Expert Council visits the place of the property or the resource with the court commission, and listen all the related people. The Expert Council shall consider the following criteria during the valuation:

- (i) type and quality of the property;
- (ii) surface area;
- (iii) all the qualities and components of the property or the resource that can affect its value, and the value of each component;

- 
- (iv) the tax statement, if any;
  - (v) valuations made by official authorities on the date of expropriation;
  - (vi) net revenue to be obtained from a property or resource on land, provided that the property or the resource is used at that location and under the same conditions as on the date of expropriation, and is used in its original condition;
  - (vii) for house plots, the sale value of similar land sold before the date of expropriation;
  - (viii) for structures, official unit prices and construction cost estimates and taking into account depreciation of structures;
  - (ix) other objective measures that will affect the determination of the expropriation value.

The Expert Council estimates the value of the property based on an evaluation report that includes comments on all the aforementioned criteria.

### ***Valuation of Structures***

Compensation for buildings is provided at replacement cost determined according to use and construction type. Every year a communiqué is published by the Ministry of Public Works and Settlements<sup>1</sup> on “Average Unit Costs of Buildings used for Calculation of Costs for Architecture and Engineering Works”. The condition of the building is taken into account by considering whether any maintenance and repair has been carried out. The value of any materials that would be available for re-use after demolition of the building is not deducted from the compensation value.

### ***Valuation of vegetation***

Vegetation, particularly trees, is valued according to economic yield also assessing subjective factors such as age and species of the plants on the expropriated land. The land cannot be evacuated until the harvest is completed, unless a separate value for crops (ekin bedeli) is determined and paid to the owner in advance.

### ***Payment of expenses***

The expropriating authority must bear all costs including legal fees in cases where the expropriation value is determined by the court, including remuneration of experts assigned by the courts, costs incurred by the village leader when he is consulted during the survey, fees for registration of title deeds and any other necessary expenses.

Since only the State and public corporations are entitled to expropriate or impose administrative servitude on all or part of the property on privately owned lands by Expropriation Law, the company does not have control or influence related to this procedure. However, in the Environmental and Social Management System; entities involved in the process, roles they play and the corresponding risks they present will be identified. Moreover, in order to achieve

---

<sup>1</sup> The Ministry of Public Works and Settlement has been closed and the equivalent Ministry is now the Ministry of Environment and Urbanization as of June 2011.

environmental and social outcomes that are consistent with IFC PSs, collaboration opportunities with the responsible parties will be sought during the process.

#### 5.4.2 Expropriations requested by HEMA

There are a total of 11 parcels within the Project area which HEMA requires to be expropriated. Ten of these parcels are around Shaft-1 and the other one (No: 1052) is located in Shaft-3 area. There are some private parcels located on Spoil Dumpsite-1 area which are to be expropriated (Figure 5-10). Land sections within the boundaries of Spoil Dumpsite-1 (No: 119, 123 and 122) are requested to be expropriated. As it is seen on Figure 5-10 and the parcel (No: 118) resides within the area of Coal Storage-2 and this land section is also requested for expropriation. Additionally, there are a total of six parcels (No: 107, 108, 111, 112, 113, and 114) are requested for expropriation since they are located within the conveyor area.

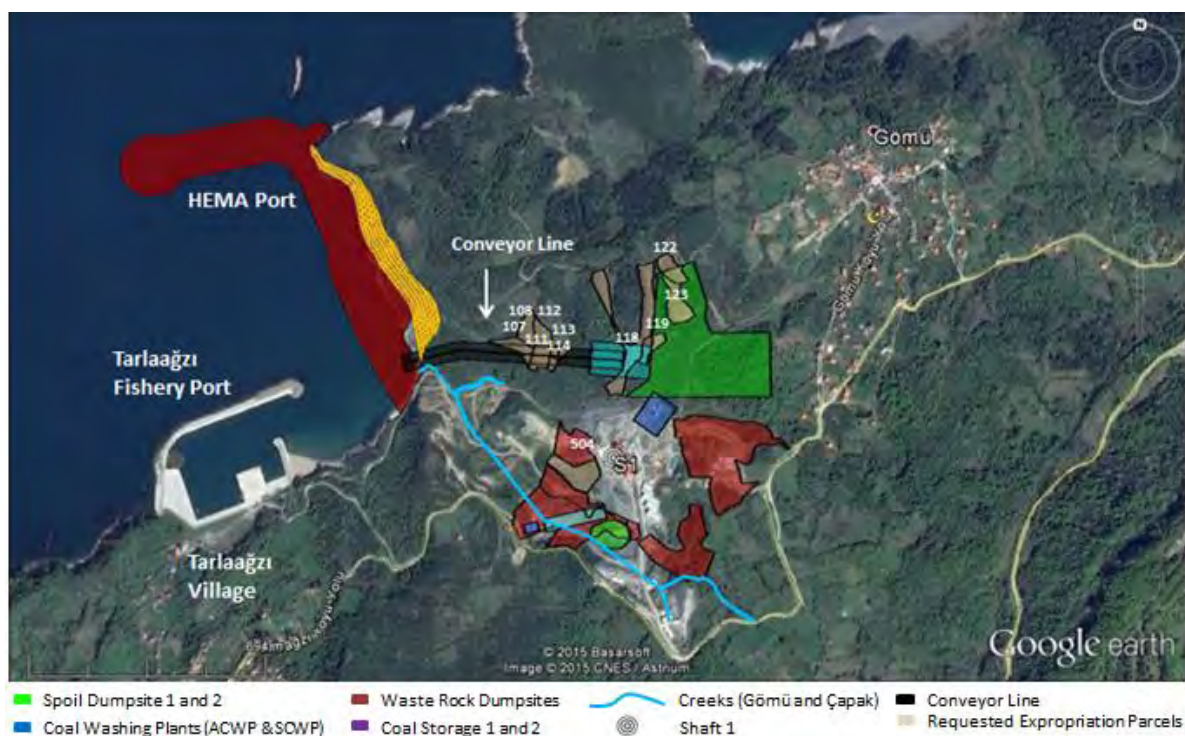

Figure 5-10: The land sections requested for expropriation around Shaft-1 area

Waste Rock Dumpsite near Shaft-2 is defined as forestland which is pending for permission; however, there are some land sections owned by HEMA and three private parcels (No: 885, 907 and 908) within the area. Although, there is also a private parcel (No: 1021) situated within the boundaries of the proposed Waste Rock Dumpsite area, it is not requested for expropriation. There are also 15 parcels situated within Shaft-2. However other parcels are not demanded for expropriation yet. The number of parcel required to be expropriated may increase as a result of a project development such as increase in the capacity due to future expansions and another project application.

Table 5-3: Total surface areas and locations of parcels requested for expropriations

Location	Land Type	Surface Area (m <sup>2</sup> )
Shaft 1 (Gomu)	Agricultural Field (107,108,111,112,113,114,118,119 and 122)	49,710
	Not Known (123)	5989.70
	Total	55,699.70
Shaft 3 (Amasra District Center)	Agricultural Field (1052)	9415

According to the Social Baseline Survey Report, for the majority of the landowners, agriculture is not the primary source of income; on the other hand, 79 households carry out agricultural production within the subject area. Although, majority of the area is regarded as forestland, forestry is not a primary source of income.

Additionally, the location of production blocks are defined in *Chapter 2: Project Description*. Bostanlar village, Karayusuflar and Camlik quarters are located above East Production Block and coal will be produced at levels between -450 and -500 under these settlements. Settlements' levels are between +250 and +300 which mean the production will take place 700-800 m deep. It is been calculated that 54-64 cm subsidence may occur after 8-10 years. "Filling" will be done to minimize the subsidence. There is no settlement above West Production Field. In southeast, production will be done 900 m deeper than settlements level. The expropriation of any parcel in Bostanlar village, Karayusuflar and Camlik quarters is not currently anticipated regarding the subsidence risk. However, in case any subsidence occurs in this field, those areas will be expropriated.

### 5.4.3 Regional Plans and Zoning

The existing Project area is included into the 1/100,000 scaled Zonguldak-Bartın-Karabuk Planning Zone Environmental Plan (Approval Date: 03.05.2012). HEMA Port area is classified as "forestland". The majority of Shaft-1, Shaft-2 and Shaft-3 area is classified as "forestland" together with "marginal agricultural land and meadow" and small portion is "Public Enterprise Area Requiring Wide Area Usage". All types of zone classifications present in the environmental plan which are shown in Figure 5-11.



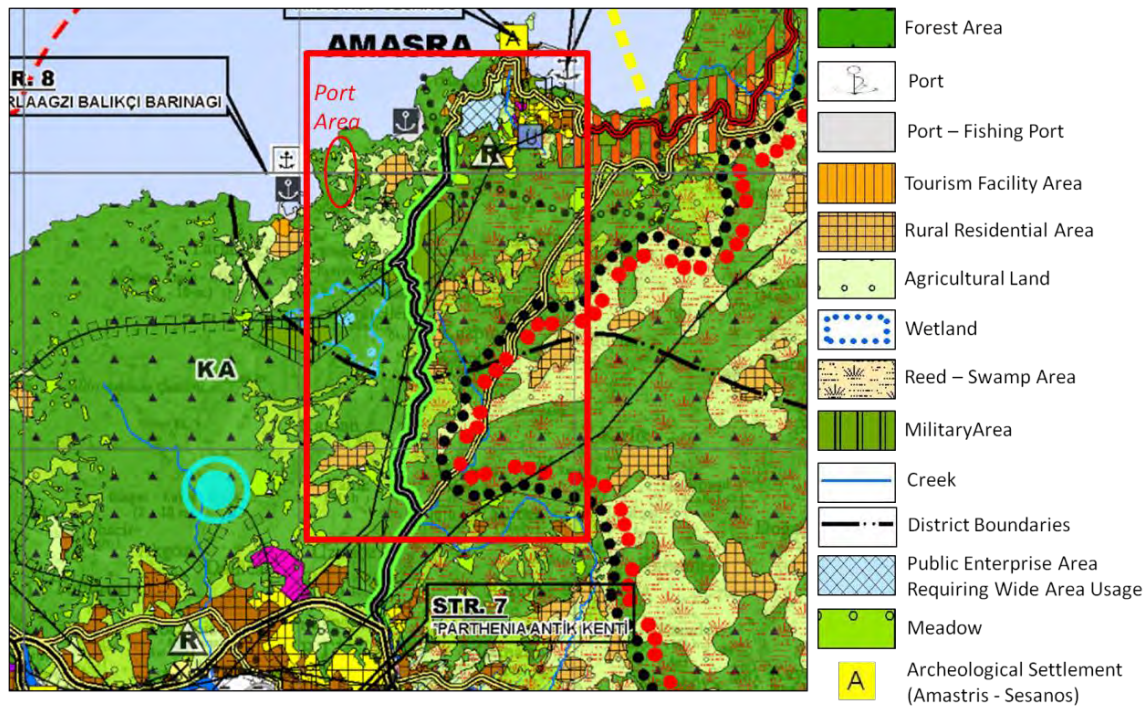

Figure 5-11: Section of 1/100,000 scaled Zonguldak-Bartın-Karabuk Planning Zone Environmental Plan (Project area schematically shown by red line and not part of the plan)

The Project area is also included into the 1/25,000 scaled Zonguldak-Bartın-Karabuk Planning Zone Environmental Plan (Approval Date: 10.04.2014). HEMA Port area is classified as the “forestland” consisting partially “the areas for afforestation” and there is an area to the top of the cape Kadırğa which is marked as “archaeological site” (shown in Figure 5-12). There are also some areas around the Gomu Village that classified as “marginal agricultural land”.

Shaft-1 area (including SCWP, ACWP, Spoil and waste rock dumpsites, storage areas etc.) is classified as “forestland” together with “marginal agricultural land”. The opinion letter obtained from Ankara Provincial Directorate of Environment and Urban Planning (dated: 3.08.2012/numbered: 252.01/363) stated that there are no proclaimed protected areas within the proposed site for Coal Washing Plant. However, Shaft-2 area and waste rock dumpsite near Shaft 2 are marked as “forestland”. The Shaft-2 area stands next to “Drinking and Utility Water Short Distance Protection Area”. Any action associated with the excavation activities and solid waste disposal/storage is forbidden within the short distance protection zone pursuant to Regulation on Water Pollution Control (Dated/Numbered: 31.12.2004/25687; last amended on 30.11.2012).

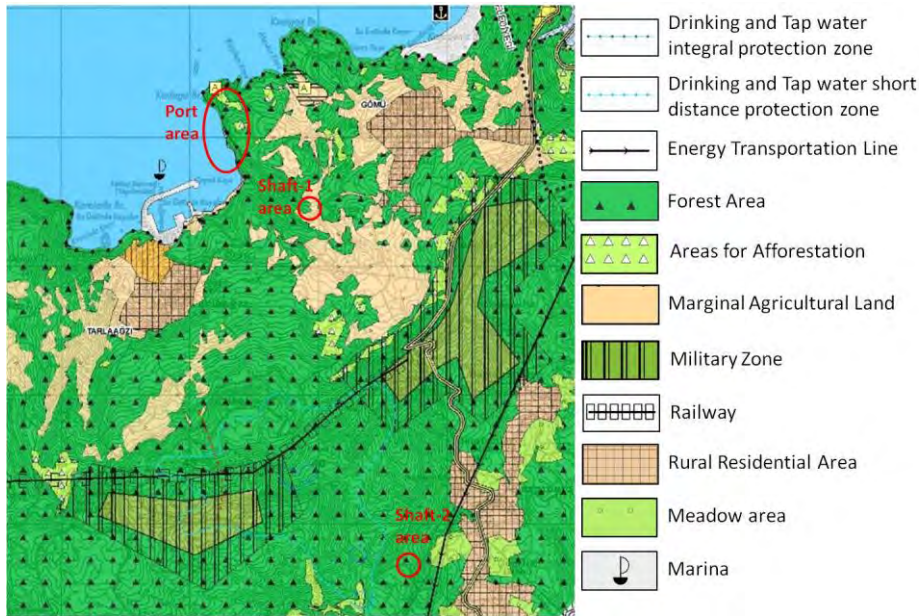

Figure 5-12: Section of 1/25,000 scaled Zonguldak-Bartın-Karabük Planning Zone Environmental Plan around Shaft 1 and HEMA port (Project area schematically shown by red line and not part of the plan)

Shaft-3 area is defined in the plan as “Public enterprise areas requiring wide area usage”. A part of the Shaft-3 area was previously defined as “archaeological site”. Upon the opinion letter from the authorities, the ventilation shaft planned to be drilled within the land (No: 1057) was shifted to be outside of the archeological site boundary. Therefore, no action is required by authorities in the current situation as stated in the opinion letter obtained from Karabük Regional Council Directorate of Conservation of Cultural Assets (dated/numbered: 16.10.2007/1293). Additionally, according to the letter obtained from Karabük Regional Board Directorate dated: 01.10.2012 and numbered: 252.01/307, the technical staff conducted a study and as a result no cultural assets were found in the three proposed Shaft areas, Tarlaagzi port, fishing port, conveyor line, and coal storage area pursuant to Law on Protection of Cultural and Natural Assets (No: 2863).

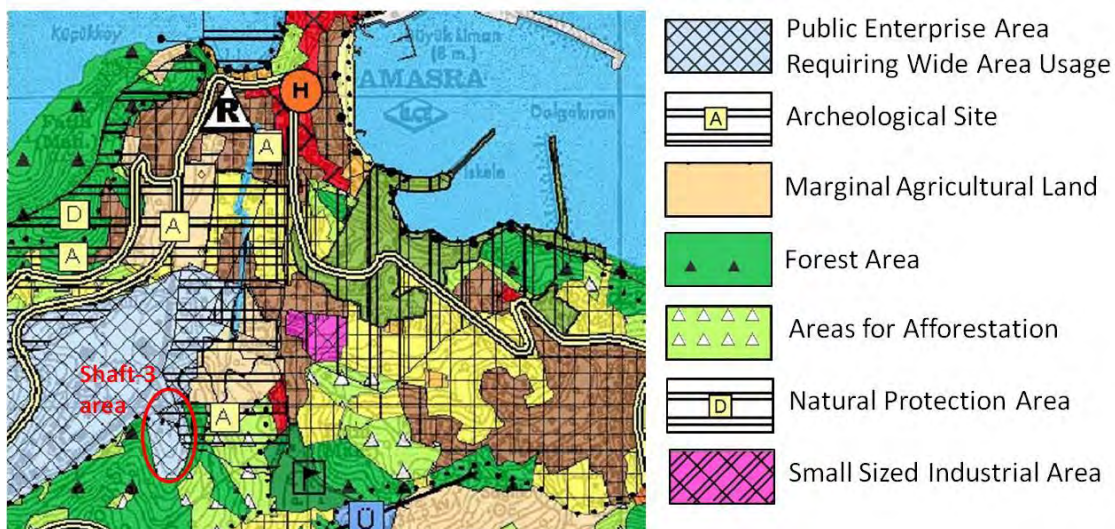

Figure 5-13: Section of 1/25,000 scaled Zonguldak-Bartın-Karabük Planning Zone Environmental Plan around Shaft 3 (Project area schematically shown by red line and not part of the plan)

## 5.5 Impacts

This section identifies the impacts of the Project in terms of existing land use on land take plots with constructed HEMA project components and expropriations to be requested. The impacts on land owners are further identified in detail and discussed in *Chapter 14 Socio-economy*. The project comprises the construction of Shafts, two coal washing plants, coal storage areas, waste and spoil dumpsites and HEMA port (reclamation area and quay). The Project area is situated in an area having a variety of land classifications. These lands and assets mainly consist of “individual agricultural lands”, “forestlands”, “public enterprise area” and “residential lands”.

Agriculture is not a primary source of income in the region. The products obtained from the agricultural lands are mainly used for individual consumption and not commercially sold due to low production capacity.

Due to the distribution of Project components, HEMA required lands to conduct Project activities on. For this purpose, HEMA made arrangements with the land owners and acquired the property based on “willing buyer” and “willing seller” basis. HEMA purchased 44 parcels in Shaft-1, 15 parcels in Shaft-2 and one parcel in Shaft-3 voluntarily from land owners which are named as “willing sellers”. The Project involves the purchase of approximately 60 private lands spread across the Gomu and Kazpinari Village and Amasra District Center. Associated impacts of the type contemplated under PS5 (Land Acquisition and Involuntary Resettlement) in the followings.

As a result of mining activities, it was calculated that about 54-64 cm subsidence may occur within 8-10 years and likely to affect Bostanlar, Karayusuf and Camlik villages. This phenomenon will be monitored by HEMA in line with the IFC Performance standards and HEMA will take precautions to minimize the impacts associated with any physical and/or economical displacement that may arise as a result of subsidence. Resettlement action plan and /or Livelihood Restoration Plan may be required.

There are three creeks existed on the proposed Project areas. Two of them (Gomu and Capak creek) are present in the vicinity of Shaft-1. According to the letter obtained from 23<sup>th</sup> Regional Directorate of State Hydraulic Affairs, waste materials and tree branches generated from the facility should be managed before damage occurs. Adaptive management strategies should be included in waste management plans. Other than that, there is a creek passing through the waste rock dumpsite near Shaft-2. HEMA installed a cement culvert to ensure the protection of stream bed.

The previous land take achieved on a mutual consensual basis, and therefore it did not cause any involuntary resettlement. The associated impacts of land use activities are summarized below for each shaft area (including the Project components in the proposed areas), and HEMA port.

### Shaft-1, Spoil Dumpsites 1 and 2

- The land use damage will be within the footprint of the proposed site for Shaft-1. The impact of reduction of forestlands, agricultural production or alteration of land is moderate for the Project components included in the proposed area (shafts, coal washing plants, coal storage areas, spoil dumpsites, waste rock dumpsites and conveyor belt). The land use impact will continue as long as mining activities takes place and unless necessary precautions undertaken.

- Surface area of 44 parcels in the vicinity of Shaft-1 is approximately 225,255 m<sup>2</sup> which is owned by HEMA based on willing seller/buyer basis agreement. The entire footprint is cleared and will be utilized continuously related with the spoil dumpsite, coal storage area, coal washing plants, waste rock dumpsites and the conveyor belt. Possible direct impact is expected on land use change. (Coal Storage-1 will be located in an area of 6,400 m<sup>2</sup>, Spoil Dumpsite-2 will be located in an area of approximately 7,186 m<sup>2</sup>, area of 8,000 m<sup>2</sup> is reserved for establishing 500 t/h capacity ACWP and 900 m<sup>2</sup> is reserved for 200 t/h capacity SCWP, Coal Storage-2 will cover an area of approximately 16,000 m<sup>2</sup>, conveyor belt will be located and permitted in an area of 32,428.90 m<sup>2</sup>, waste rock dumpsites has an area of 112,364 m<sup>2</sup>, Spoil Dumpsite-1 will be located in an area of approximately 88,465 m<sup>2</sup>).
- The impacts are related with the loss of productive land and related income opportunities as a result of Project activities. There are ten parcels requested to be expropriated by related authorities around Shaft-1 area. In case the owners use their lands for agricultural purposes, it is likely for them to be sensitive concerning the expropriation process and resultant loss of income.
- The overall significance impact of land use may change between minor to moderate around Shaft-1.

#### Shaft-2 and Waste Rock Dumpsites

- Total surface area of Shaft-2 is 116,737 m<sup>2</sup> (having 15 land sections) and it is owned by HEMA. The area consists of 149,354 m<sup>2</sup> of waste rock dumpsite area and 1004 m<sup>2</sup> of soil disposal area. The potential land use will be confined within the footprint of the proposed area of Shaft-2 including waste rock dumpsites. The impact on land use ranges between minor to moderate if the area stands outside of the “Drinking and Utility Water Short Distance Protection Area” in line with the Turkish regulations and opinions of the related authorities.
- No parcel is requested to be expropriated in Shaft-2 area from TTK for the Project activities although some private parcels are present inside the proposed Project area. HEMA have intention to take those land thorough negotiations depending on mutual willing seller-buyer basis.

#### Shaft-3

- The proposed surface area of Shaft-3 is approximately 18,810 m<sup>2</sup> which is owned by HEMA.
- The loss of land use will be confined with the footprint of Shaft-3. The impact of land use will be on surrounding communities because of its proximity to the residential areas.
- The potential impact due to land use will be lesser degree since the activities including the ventilation drilling was shifted the outside of the sphere of influence of mentioned archaeological site.
- The overall impact of Shaft 3 associated with land uses will be minor.

---

## Port Area (Reclamation Area and Quay)

- The surface area of proposed HEMA port is approximately 163,000 m<sup>2</sup> and the impact on land use activities will be confined within the footprint of the proposed port area.
- The area is located very close to Tarlaagzi Fishing port, therefore the impact, associated with the port construction on the fishing port will be moderate.
- The impact of land use activities on alteration of land will be minor to moderate due to slope protection area.

## 5.6 Mitigation Measures

Mitigation measures to avoid and/or mitigate the potential impacts related with land uses will need to include the followings;

- In line with the IFC, Environmental Health and Safety Guidelines for Mining including the management of land use and biodiversity, integrating the conservation needs and management regarding the land use needs of local communities is critical.
- The project will be designed, constructed and operated in line with the Turkish and international regulations and standards, and authorities' opinions; risks associated with the land use (mentioned above) will be minimized to a lesser degree.
- Project components, any construction and operational activity will be fenced to minimize disturbance to surrounding areas.
- Planning of the project component and operation of the facilities will protect the sensitive areas such as "Drinking and Utility Water Short Distance Protection Zone" which is situated outside the borders of the defined Waste Rock Dumpsite around Shaft-2. Moreover, any kind of waste dumping and storage will be prohibited and buffer zones will be implemented for vulnerable areas.
- Design and operation of the each project components will be done to minimize erosion, any damage to creek or stream bed and mass wasting.
- The proportion of requested expropriation is highest in Shaft-1 surrounding area. HEMA will seek to apply feasible alternative project designs to minimize the area of land take and expropriation required and to reduce the need to acquire larger parcels of land more than its necessary for the Project.
- The expropriation process is currently ongoing in accordance with the above-referenced laws in *Section 5.4.1. Expropriation Process*. The existing expropriation process and relative expropriation and land take that will be possible in the near future due to project activities shall be evaluated in terms of mitigations not only for Turkish legislations but also IFC PS 5 "Land acquisition and involuntary resettlement".
- During expropriation process, HEMA will monitor the process and collaborate with the responsible government agency.
- Physical and economical displacement will be minimized through the alternative and feasible project components design; when the economical displacement is unavoidable, HEMA will ensure appropriate compensation plan named "Livelihood Restoration Plan" including of the displaced people who face loss of lands or access to lands or income levels adversely affected. Additionally, since several locations within the project site consists of not only residential area(buildings) but also individual lands such as gardens and farms,

they should receive assistance to re-establish a garden or farm at new location. The assessment should be based on land tenure issues as a mitigation measure, HEMA will ensure that people have the same land tenure status.

- Private owners with registered title to land or property which is to be expropriated will be compensated for their loss and thereby provided with an alternative land agreement.
- Any damages to lands, crops, assets and livestock in the neighborhood which might be occur during both construction and operational phase of the project will be compensated by HEMA.
- The protection of the original state of land pattern will be paramount. For this purpose, loss of forestland will be compensated through afforestation according to the inventory of Ministry of Forestry which will also be covered in the Site Rehabilitation Plan to be prepared.
- Towards the end of the life of the proposed project, the post closure procedures should comply the objectives and targets identified in Site Rehabilitation Plan.

## 6.0 GEOLOGY AND SOILS

### 6.1 Scope

This chapter presents an evaluation of the predicted impacts of the Project related to geology and soils. The following issues are addressed: (1) Impacts related to geology and seismicity, (2) Impacts related to soil loss, (3) Impacts related to soil quality. A description of the significance criteria to complete the impact assessment is provided followed by a description of the baseline situation. The potential impacts for the issues noted above are discussed and the proposed mitigation measures are presented together with the residual impacts.

The results from the following desktop study resources and site-specific investigations were used to establish the baseline information:

- Literature survey,
- Bartın Province Environmental Status Report (2011),
- Amasra Hard Coal Production Project Report by SRK (October 2013),
- An Independent Technical Report on the Amasra B Coal Mine, Bartın Province/Turkey by SRK Consulting UK (Draft report, February 2014),
- Hydrogeological and Geological Characteristics of Southwest Amasra - Report by ENVIS (February 2012),
- Environmental Impact Assessment Report for HEMA Port (Reclamation Area and Quay) prepared by Dokay-ÇED Ltd. (April 2013),
- Project Introduction File for HEMA Coal Washing Plant prepared by Dokay-ÇED Ltd. (January 2014).

The necessary criteria (e.g. appropriate standards, regulations, etc.) will need to be taken into account in the design of the facilities and structures to address the seismic risks. Design of structures will satisfy the criteria for 1<sup>st</sup> degree earthquake zones where the Project site is located.

The following significance criteria are suggested related to potential soil quality, soil loss and geological impacts;

Significance	Impact Description
Not Significant	- Temporary use of land (with soil surface) for the storage of excavated materials and equipment
Minor	- Temporary small-scale contamination of soils during construction activities that leads to contamination below generic limit values of the Turkish Regulation on Soil Pollution Control and Point-Source Contaminated Sites (RSPC) - Minor changes in grade and insignificant impact on settlements and structures caused by land subsidence - Localized and/or short term soil loss (no erosion)
Moderate	- Continuous/long-term contamination of soils during construction activities and during operation (e.g. accidents, contaminant leaching through storage areas or dumpsites) that leads to contamination above the generic limit values of the RSPC - Moderate changes in grade and medium (easily repairable) impact on settlements and structures caused by land subsidence which can be remedied without functionality loss - Mid- to long-term soil loss and/or soil loss on medium-sized landscapes of sensitive nature
Major	- Continuous/long-term contamination of soils during construction activities and during

Significance	Impact Description
	<p>operation (e.g. accidents, contaminant leaching through storage areas or dumpsites) that leads to contamination above the generic limit values of the RSPC, and causing long term cancer and hazard risks</p> <ul style="list-style-type: none"> <li>- Significant changes in grade and severe impact on settlements and structures caused by land subsidence, which will require expropriation and resettlement due to functionality loss</li> <li>- Permanent soil loss and/or soil loss on medium to large sized landscapes of sensitive nature</li> </ul>

## 6.2 Existing Environment

### 6.2.1 Geology and Tectonics

#### Regional Geology

The Amasra coalfield is part of the coal-bearing Carboniferous deposits that occur along the Black Sea coast of Turkey. These Carboniferous rocks of the coalfield are partially exposed in the west and are mostly overlain by sequences of Permian and Cretaceous strata in the region. The regional geological map of Amasra is provided in Figure 6-1 and the lithological units forming the basin are further detailed below.

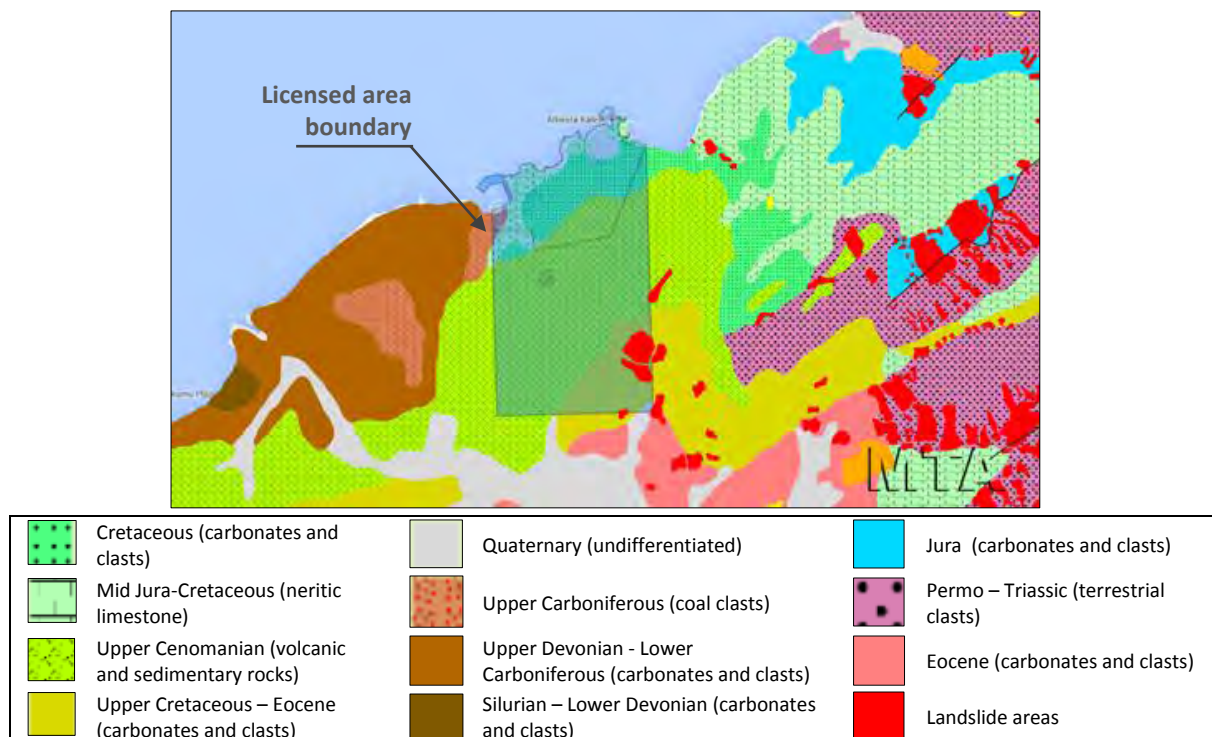

Figure 6-1: Regional geological map <sup>1</sup>

<sup>1</sup> MTA - Turkish General Directorate of Mineral Research and Exploration, <http://yerbilimleri.mta.gov.tr/anasayfa.aspx>



GENERALIZED STRATIGRAPHIC COLUMN OF BARTIN - AMASRA BASIN																
UPPER SYSTEM	SYSTEM	SERIES	AGE	THICKNESS	ID.	COLUMN SECTION	LITHOLOGY	OROGENY AND PHASES								
PALEOZOIC	CARBONIFEROUS	LOWER CARBONIFEROUS	VIZELI	100-1000 m.	kk		Dolomitic limestone	Sudetic	H E R C Y N I A N							
		UPPER CARBONIFEROUS	ALACAAGZI	200-570 m.	ko		Sandstone, claystone, coal									
		WESTPHALIAN A	KÖZELL	100-1000 m.	kk		Conglomerate, sandstone, claystone, coal									
		WESTPHALIAN B-C-D	KARADIN	200-750 m.	kk		Conglomerate, sandstone, claystone, coal									
		MESOZOIC	CRETACEOUS	PERMIAN	AMIT DERE	35-350 m.	PTe			Conglomerate, sandstone, claystone	Austrian	A L P I N E				
				TRIASSIC	YUNUSLU	5-25 m.	kb			Marly limestone						
				CENOZOIC	QUATERNARY	PALEOGENE	Subhercimian	DINLENCI		10-150 m.	Krl		Agglomerate, andesitic tuff	Subhercimian		
						AGGLOMERATE	AGGLOMERATE	10-150 m.		Krl			Agglomerate, andesitic tuff			
						ANDESITE	ANDESITE	60-500 m.		Kkz			Andesite			
						MARLY LIMESTONE	MARLY LIMESTONE	15-200 m.		Km			Marly limestone			
						CENOZOIC	QUATERNARY	NEOGENE		Laramian					Alluvion	Laramian
								PLIOCENE								
								PLIOCENE								
								PLIOCENE								

Figure 6-2: Generalized stratigraphic column of Amasra basin

As illustrated in the stratigraphic column of the Amasra region given in Figure 6-2 above, the geological structure of Amasra region comprises lithological units aged Paleozoic, Mesozoic and Cenozoic (Quaternary).

Paleozoic aged units are composed of Carboniferous and Permian aged formations. The Carboniferous aged formations contain coal bearing units and from bottom to top are as follows;

- Yilanli formation: This Devonian-Visean aged formation consists of dolomite, limestone, and dolomitic limestone deposits, in varied colors of grey, black, dark brown and light brown.
- Alacaagzi formation (Namurian): It is formed of shale, sandstone, siltstone and claystone sequences with thin and discontinuous coal seams in its upper part. Alacaagzi formation lies

on Yilanli formation with intercalations and contains delta and prodelta front deposits. The formation varies from 200 to 570 metres in thickness and its color is dark grey and grey.

- Kozlu formation (Westphalian A): This Westphalian aged formation is up to 1000 metres in thickness and lies on Alacaagzi formation. It is composed of conglomerates, sandstones, claystones and mineable coal seams.
- Karadon formation (Westphalian BCD): This coal bearing formation lies over the Kozlu formation and outcrops around Tarlaagzi and Gomu Villages. Karadon Formation comprises mainly conglomerates, sandstones and claystones and the lower part contains the most economical coal seams. Its thickness varies between 200-750 m. The sediments in the lower parts of the Karadon Formation are grey to dark grey while in the upper parts they are reddish grey in color. Karadon formation is analyzed in three units, namely Westphalia B, Westphalia C and Westphalia D from bottom to top. Westphalian B consists of sandstones, siltstones, claystones and coal seams. Westphalian C occurs between Westphalia B and Westphalia D units and consists of conglomerate, sandstones, claystone, siltstones and minable coal seams. Westphalian D consists of claystone, siltstone, conglomerate, sandstone and shale, with the thin coal seams generally having no exploitable features.

Carboniferous series is overlain by Permian aged rocks which are characterized by the Aritdere formation. This formation consists of red colored conglomerates, sandstones and mudstones; it is unfossiliferous and devoid of coal seams. It appears conformably deposited over the Carboniferous formations and unconformably overlain by the Lower Cretaceous limestones. Thicknesses reach a maximum of 350 meters.

Mesozoic units in the region are represented with Cretaceous aged formations, which are analyzed as Lower Cretaceous and Upper Cretaceous aged formations. Lower Cretaceous units consist of Gomu Formation and Amasra Formation. Gomu formation transgresses over the older Paleozoic formations and consists of Barremian aged limestone of thicknesses ranging from 35 to 500 meters. The Apsian aged Amasra formation displays flysch characteristics and exists as sandstone with carbonates, claystone, siltstone and ammonite-bearing blue marls. Its thickness is up to 100 metres.

Paleozoic and Lower Cretaceous aged units are overlain by Upper Cretaceous formations which consist of the following (from bottom to top); Ahatlar formation, Askersuyu formation, Dinlence formation, Ugurlar formation, Kazpınar formation and Alaplı formation. Ahatlar formation is Cenomanian aged and its thickness ranges between 5 and 350 metres. It lies unconformably on Gomu and Amasra formations and lithologically it consists of gray and grayish white sandy limestone. Ahatlar formation is conformably overlain by the Turonian aged Askersuyu formation, which is formed of pink, gray and white colored marly limestone. Its thickness varies between 5 and 25 metres. Askersuyu formation is conformably overlain by Dinlence formation which is Santonian-Coniacian aged and 30 to 350 metres thick, with sequence of agglomerate, marly limestone and andesitic tuff formed by undersea volcanism. Dinlence formation is overlain by the Campanian aged Ugurlar formation composed of marly limestone and tuff sequence. This formation has a thickness ranging from 10 to 130 metres and outcrops around Bostanlar, Ugurlar and Kazpınar villages. Campanian aged Kazpınar formation, which is formed of andesites, conformably overlies Ugurlar formation and outcrops around Kazpınar and Bostanlar villages. Its thickness varies between 60 and 200 metres. The overlying Maastrichtian aged Alaplı formation represents the youngest of the

---

Upper Cretaceous units in the region, consisting mainly of white and light yellow marly limestones. The formation varies from 15 to 200 metres in thickness.

Cenozoic aged units are characterized by quaternary alluvium and slope debris composed of and volcanic rocks.

### *Site Geology*

In the licensed area, the coal bearing deposits lie above the Yilanli Formation (Visean aged and comprising principally dolomites and limestones) and are divided into three units, namely (from the lowest upwards): Alacaagzi Formation (Upper Visean to Namurian age, comprising culm facies argillites, siltstones, sandstones and thin coals in the upper part), Kozlu Formation (Upper Namurian to Westphalian A) and the Karadon Formation (Westphalian BCD). The Kozlu Formation contains seams with potential coking properties which are included in HEMA's mining plan for the West Block and the Karadon Formation steam coals which are included in HEMA's mining plan for the East and Southeast Blocks. The West Shallow Block includes seams from both Kozlu and Karadon Formations.

The Kozlu Formation (Westphalian A) is approximately up to 1000 meters thick and is a dominantly sandy succession with subordinate argillites (predominantly in the lower third), pebbly units and numerous individual coal seams, of which seven are included in the mining plan for the West Block and two higher seams in the Shallow Block. The Westphalian AB boundary appears to coincide with a notable change in lithology and spore assemblages. The overlying Karadon Formation (Westphalian BCD) is dominated by siltstones and argillites with the lower section largely grey and dark grey, and the upper section reddish grey. Refractory clays, known as schiefertone (tonstein) are sometimes present and usable as marker horizons. The one at the boundary of Westphalian BC comprises a 1-8 metres thick (average 4 metres) black/brown/cream clay and is extremely widespread and serves as the major means of elucidating the major structural elements at Amasra. Thinner cream tonsteins of a few centimetres thickness are also sometimes present within the seam sections. The overall thickness containing exploitable coals is approximately 550 metres with six seams included in the Mine Plan for the East Block. Two of the same seams are included in the Southeast Block and four in the West Shallow Block.

Underlying the Westphalian strata are Namurian sandstones, argillites and rarely coals, which in turn are underlain by dolomites and limestones of Visean (Lower Carboniferous) and Devonian age. The seams drilled within the West Block are thought to lie largely or entirely within the Westphalian A strata. However, the Namurian/Westphalian boundary has not been clearly determined.

Overlying the coal bearing Westphalian strata unconformably are Permian age terrestrial strata, comprising principally red sandstones and conglomerates, followed by marine Lower and Upper Cretaceous age rocks comprising dolomitic limestones, flysch and marls. Further Upper Cretaceous age strata lie unconformably on the underlying marine rocks and comprise layered volcanic rocks such as tuffs, andesites and agglomerates.

Quaternary alluvium overlies the solid strata in the coastal zone close to Amasra.

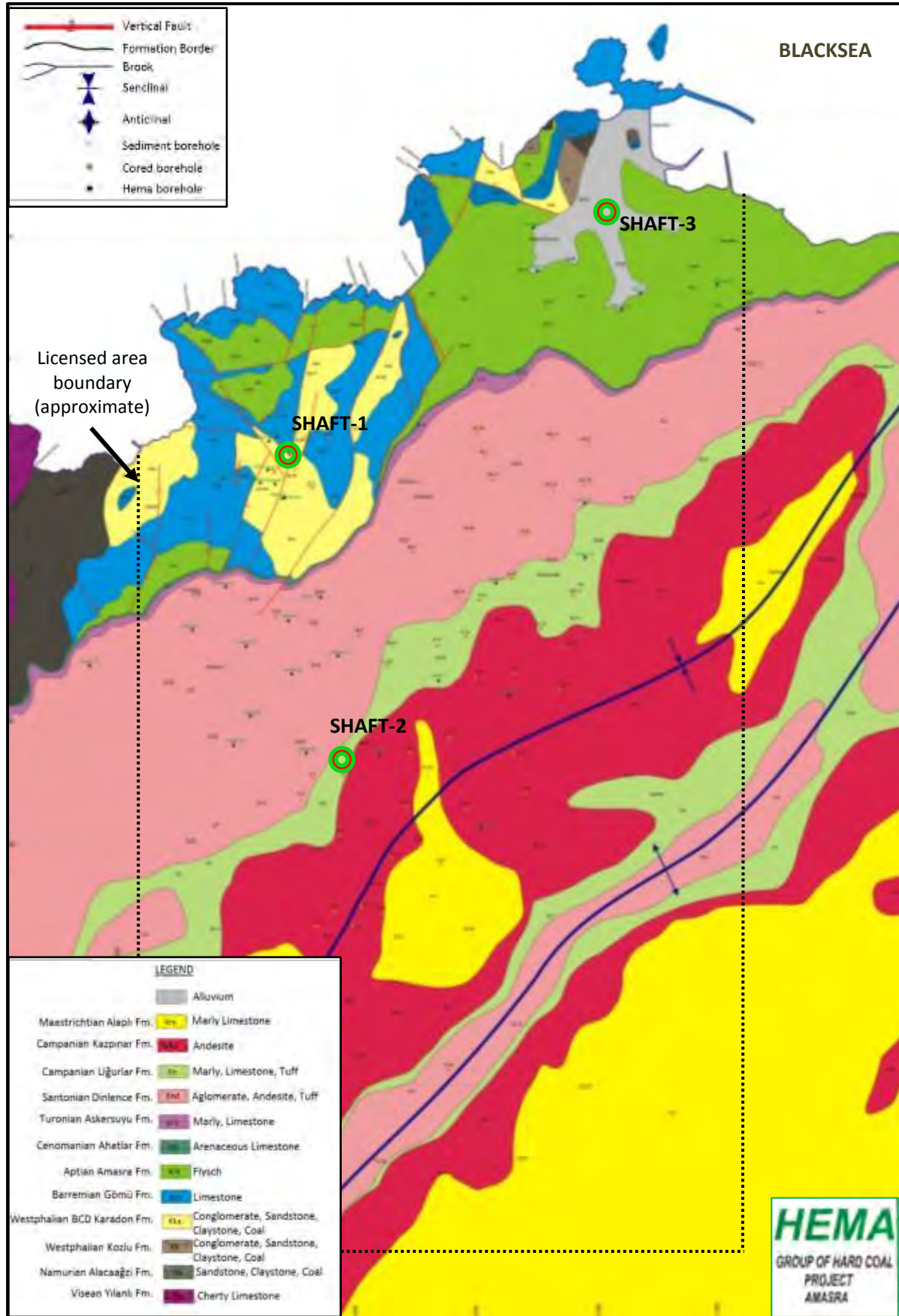

Figure 6-3: Geological map of licensed area

The geological map of the license area is given in Figure 6-3 above. Geological cross-sections (Figure 6-4 and Figure 6-5) were derived using data gathered from wireline surface drillings performed at the license area. Drilling activities at the licensed area commenced in 1956, was carried out in a number of phases, and is continuing. The first four phases were drilled by TTK, MTA and TPAO and the current phase by HEMA. Borehole locations are shown in Figure 6-6 and the phases of drilling are summarized below:

1956-1961	<i>23 boreholes drilled, rotary openholes with touch coring of coal seams in some boreholes, no coal analyses available, no down-hole geophysical logging undertaken, borehole numbers within the series SJ 21-47/85/88. Only summary lithology logs available as drawings showing geological formations and coal seam thickness and level.</i>
1974-1988	<i>60 boreholes drilled, rotary openholes with touch coring of coal seams in some boreholes, no coal analyses available, 58% geo-logged, borehole numbers within series SJ 1-20 and SJ 39-102, and SJ P1. Detailed lithological logs available for 93% of boreholes; only summary logs available.</i>
1981-1988	<i>37 boreholes drilled, wireline, fully cored, 68% geo-logged, 68% analysed, borehole series K 1-K 37.</i>
1988-1990	<i>16 boreholes drilled, wireline, fully cored, 81% geo-logged, 81% analysed, borehole series AK 1-AK 16. In 1989, a single openhole, geo-logged borehole was drilled.</i>
2007- 2013	<i>86 boreholes drilled utilizing HEMA's own Longyear rigs as part of a wireline drilling programme which is ongoing, almost exclusively with continuous coring of coal strata. Strata overlying the Westphalian are openholed and 27% of holes are geo-logged. The geo-logging is confined to boreholes which could not be successfully cored due to broken strata etc. Boreholes are given the numbers HEMA 1-86. Each borehole takes approximately 3 months to complete. HEMA 56, 67 and 78 are openholes which did not reach the Westphalian strata and were not geo-logged.</i>

### *Structural Geology*

#### *Folding*

In Amasra hard coal basin, folding associated with both the Hercynian and the later Alpine orogenic episodes has affected the coal bearing strata. The former has generally resulted in northwest-southeast orientated folds, although the basin is generally aligned east-west. Superimposed on this is the generally northeast-southwest trending Alpine folding which gives rise to the Kazpinar Syncline and Ugurlar Anticline which particularly affect the HEMA Southeast Block (Figure 6-3).

Strata generally dip in a direction between southwest and southeast, except within the south wing of Southeast Block where the dip is between east and north, at between 5-20° with the Westphalian coal bearing strata, together with the overlying Cretaceous limestones, marls and volcanic rocks, forming the high ground inland from Amasra town, as well as the upland slopes between this ridge and Bartın to the south.

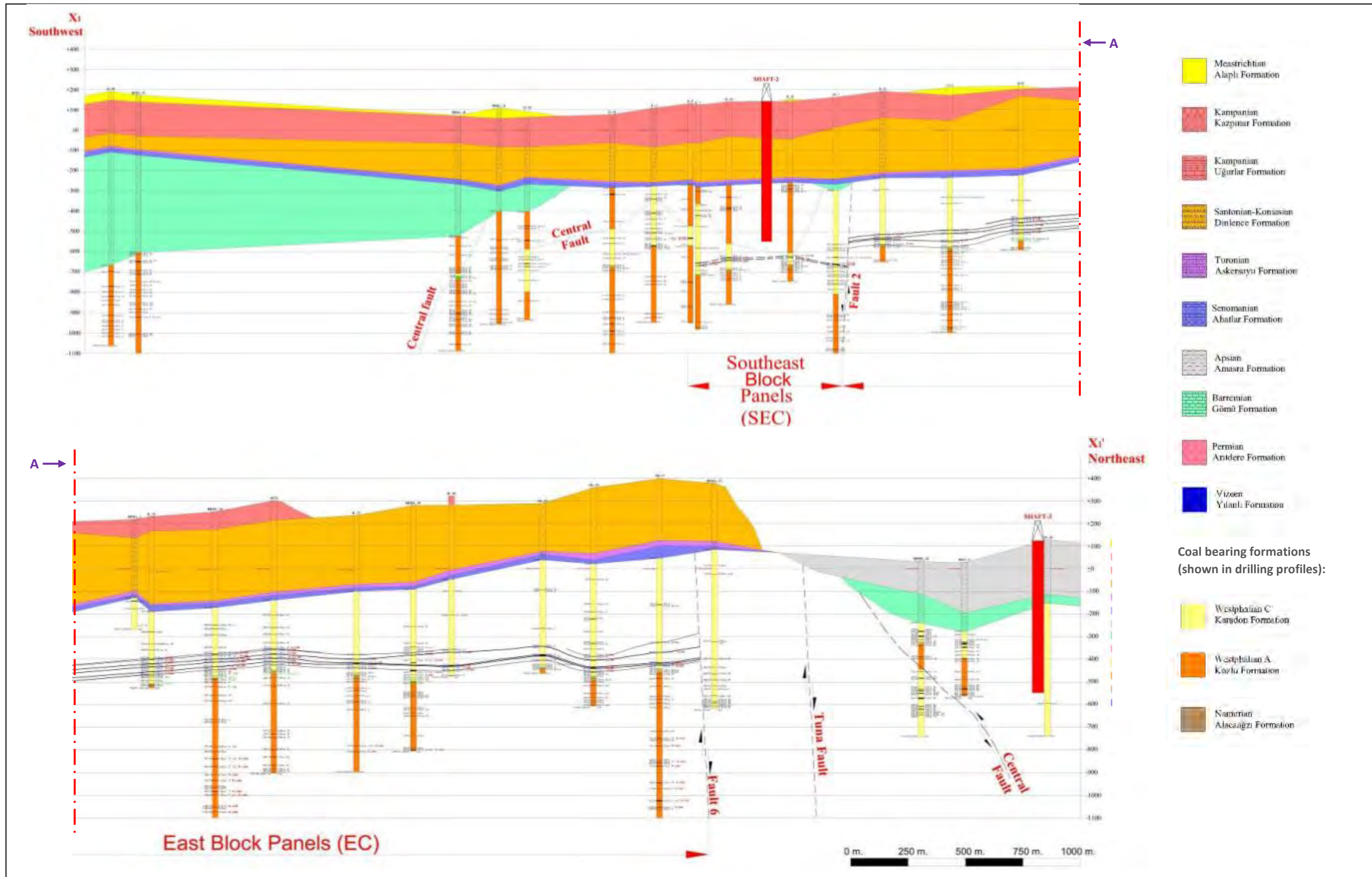

Figure 6-4: Geological cross-section of the licensed area (Southwest – Northeast)

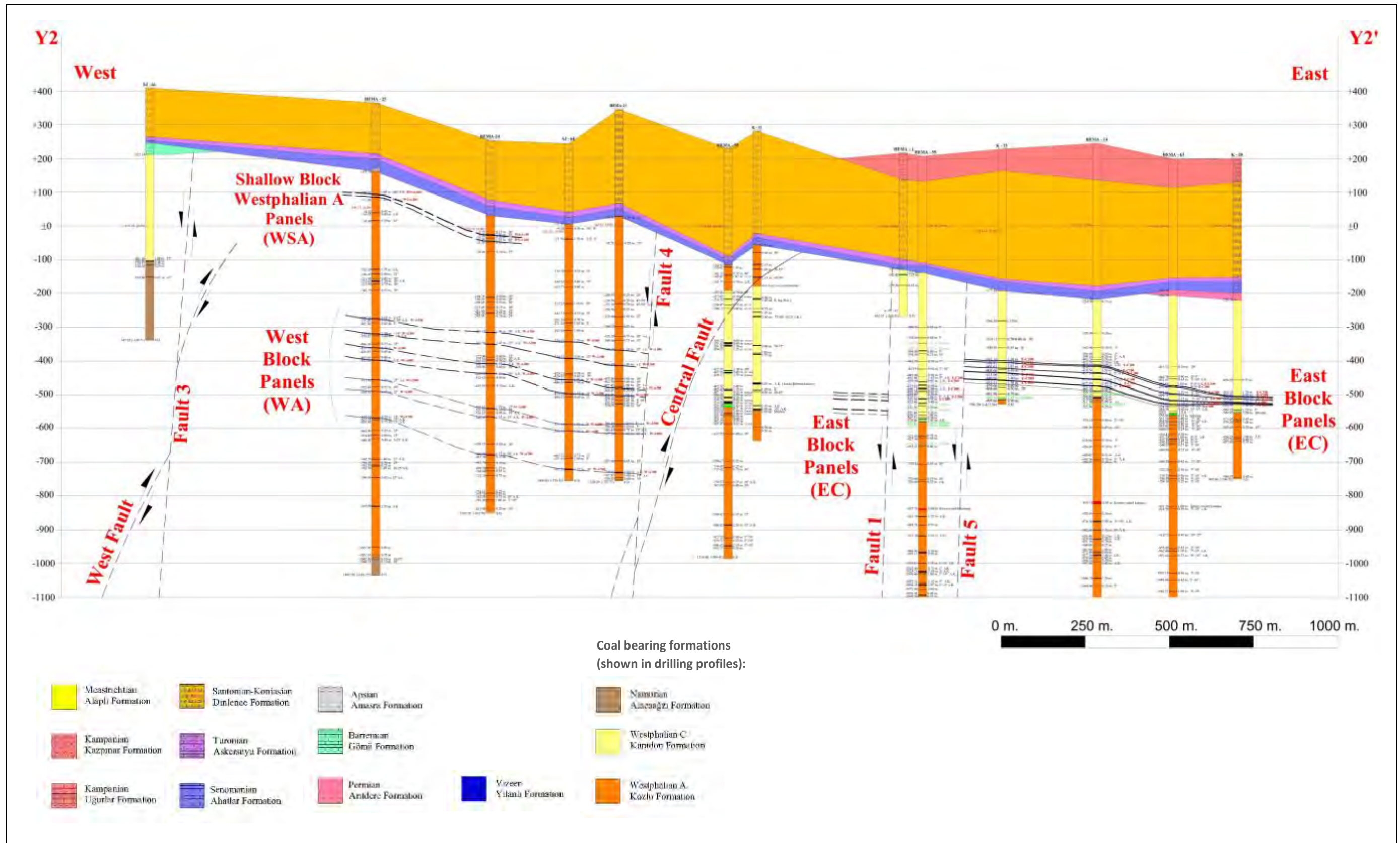

Figure 6-5: Geological cross-section of the licensed area (West - East)

## Faults

Westphalian age strata have been affected by high tectonic stresses and are cut by numerous normal, reverse faults and thrusts, with the reverse faults generally being older than the normal faults. Most of the faulting is high-angle at 60-80°. Some of the faulting is listric and some strike-slip in nature. Most of the thrusting and faulting in the area is believed to predate the deposition of Cretaceous strata (Hercynian orogeny) but to have been later modified and augmented by movement during the Alpine orogeny.

The major structure, the Central Fault (Figure 6-6), trends approximately north to south. The Kozlu formation is sometimes repeated and in places pushed westwards over the younger Karadon formation. Displacement is approximately 500-600 metres and the angle is 60-80° (from the horizontal). This fault separates the East and Southeast Blocks from the West Block of the mining plan.

A second reverse fault, namely West Fault (Figure 6-6), is postulated to form the western boundary to part of West Block and the West Shallow Block and to have a similar direction of movement and trend to the Central Fault. This dislocation thrusts Namurian strata over a Kozlu formation (Westphalian A) sequence. It has a displacement of 500-600 metres and an inclination of 60-70°.

Within Amasra B mine area, the thrust is intersected by the normal, northeast-southwest trending Tuna Fault (Figure 6-6) which downthrows 500-600 metres to the north, is at an angle of 60-80° and effectively forms the northern boundary to planned workings in East Block and the Westphalian C strata.

Numerous normal faults (Figure 6-6) with displacements of up to several tens of metres have also been interpreted as being present within the proposed extraction areas. Generally these faults trend between north-south and northeast-southwest and are summarized below;

- Fault No.1 separates the two planned working areas in the East Block and has a displacement to the west from zero in the north to 120 metres in the south and is inclined at 80-90°.
- Fault No.2, trending northeast-southwest, separates the East and Southeast Blocks and is estimated to downthrow strata 90-140 metres to the southeast and be inclined at 70-80°. Recent drilling shows that a continuation of this fault forms the eastern boundary to East Block.
- Fault No.3 forms the northwest boundary to the West Block and forms the boundary within the West Shallow Block between those seams planned for extraction from the Westphalian C and those from the Westphalian A. It trends northeast-southwest and has a displacement and inclination of 20-50 metres and 80-90°.
- Fault No.4 limits the panel layout along the eastern boundary of West Block and runs approximately parallel to and to the west of the Central Fault. It is a normal fault downthrowing strata to the west.
- Fault No.5 splits the northwest and southwest groups of panels in the West Shallow Block and downthrows to the south approximately 20 metres.
- Fault No.6 forms the northern boundary to the West Shallow Block.



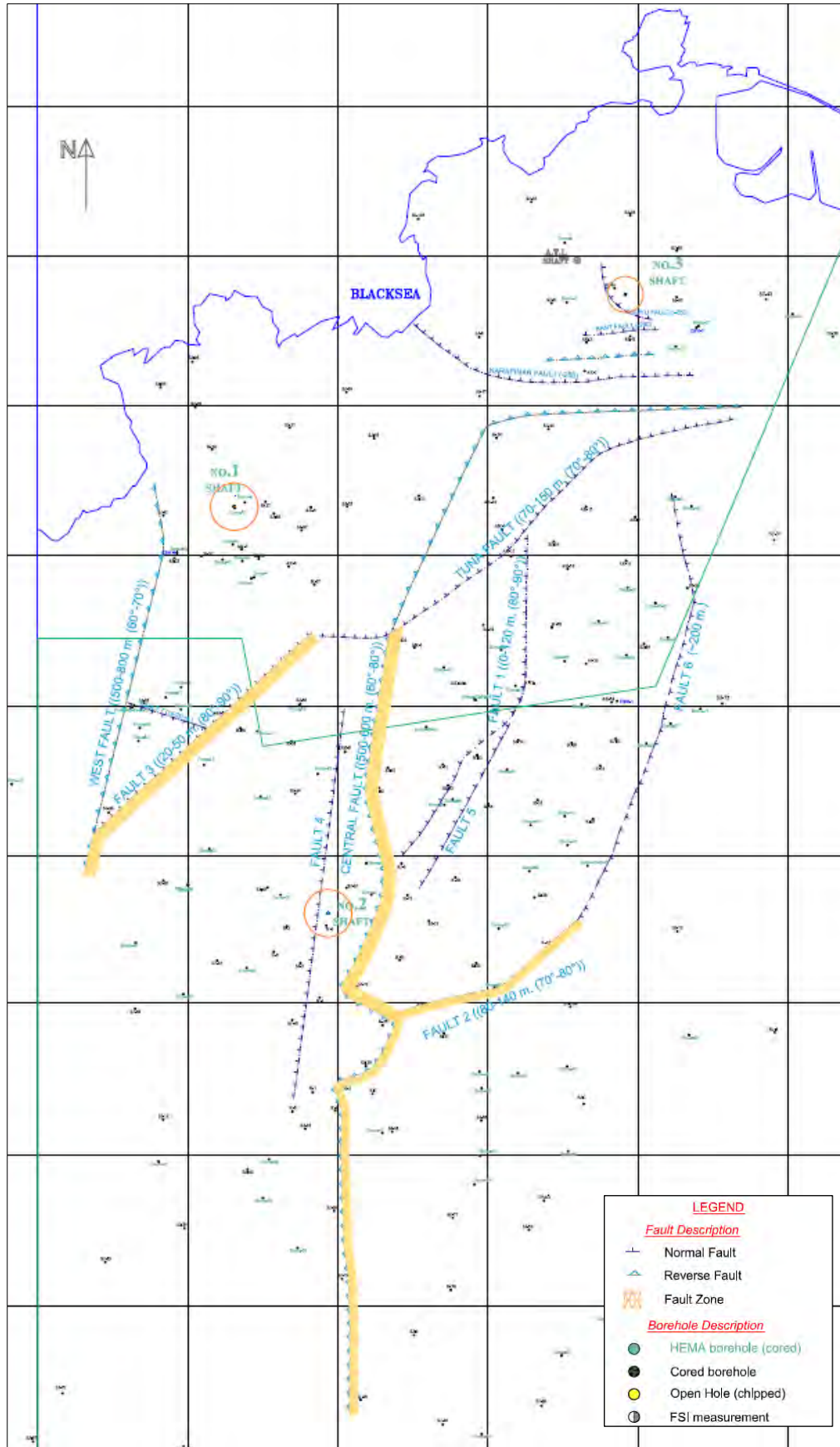

Figure 6-6: Fault map of Amasra

## Seismicity

The Project is located in an active seismic zone. Amasra and vicinity is classified as a 1<sup>st</sup> degree earthquake zone (1<sup>st</sup> degree representing the highest tectonic activity and 5<sup>th</sup> degree representing the lowest tectonic activity) according to classifications provided by the Turkish Disaster and Emergency Management Presidency (Figure 6-7).

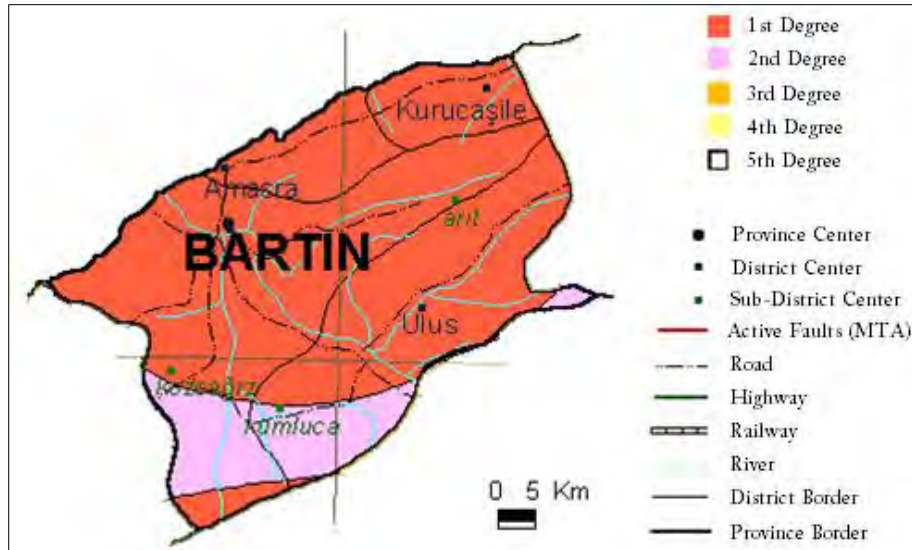

Figure 6-7: Seismic zone classification map of Bartın Province<sup>1</sup>

In Amasra region, earthquakes occur as a result of movements along the North Anatolian Fault (NAF) zone, which is an east-west trending, highly active strike-slip fault located approximately 100 km south of Amasra. NAF has experienced significant seismic activity in historical and recent times. Table 6-1 below lists the earthquake events with a magnitude greater than 4 on the Richter scale which have been recorded in the vicinity of Amasra within the last 100 years. Accordingly, the most recent remarkable earthquake in the area occurred in 2006 and had a magnitude of 4.1.

Table 6-1: Earthquakes that occurred in the vicinity of Amasra in the last 100 years<sup>2</sup>

Date	Time (GMT)	Latitude	Longitude	Depth (km)	Magnitude
20.04.2006	14:10	41.72	32.45	3	4.1
26.05.1990	12:41	42.10	32.60	10	4.0
14.02.1983	07:28	41.95	32.89	33	4.1
18.02.1976	23:07	41.88	32.42	3	4.4
04.07.1972	06:17	41.70	32.44	0	4.0
20.09.1971	10:57	41.58	32.44	0	4.2
20.09.1971	08:02	41.54	32.66	0	4.0
25.02.1969	13:43	41.56	32.27	31	4.3
10.01.1969	16:33	41.66	32.47	18	4.5
28.09.1968	03:25	41.75	32.10	38	4.1
10.09.1968	01:48	41.69	32.39	33	4.1
09.09.1968	11:49	41.66	32.22	33	4.2

<sup>1</sup> Turkish Disaster and Emergency Management Presidency; [www.deprem.gov.tr](http://www.deprem.gov.tr)

<sup>2</sup> KOERI-Bogazici University Kandilli Observatory

Date	Time (GMT)	Latitude	Longitude	Depth (km)	Magnitude
03.09.1968	21:08	41.77	32.08	55	4.2
03.09.1968	14:09	41.81	32.33	14	4.3
03.09.1968	12:22	41.78	32.45	33	4.2
03.09.1968	10:56	41.76	32.50	11	4.3
03.09.1968	09:13	41.78	32.25	33	4.4
<b>03.09.1968</b>	<b>08:19</b>	<b>41.81</b>	<b>32.39</b>	<b>5</b>	<b>6.5</b>

The largest earthquake recorded in Amasra is dated 3 September 1968 and its magnitude was reported as 6.5. The earthquake reportedly caused shore uplifting and significant rises in sea level, as well as serious damage and casualties in the area. Experts who studied the earthquake have generated isoseismal maps (Figure 6-8) and identified it as VIII according to the Mercalli intensity scale. The epicenter of this earthquake is suggested to be located approximately 10 km off Amasra, near where large scale landslips of Pliocene sediments have been recorded offshore that are attributed to thrust faulting movements in the region.

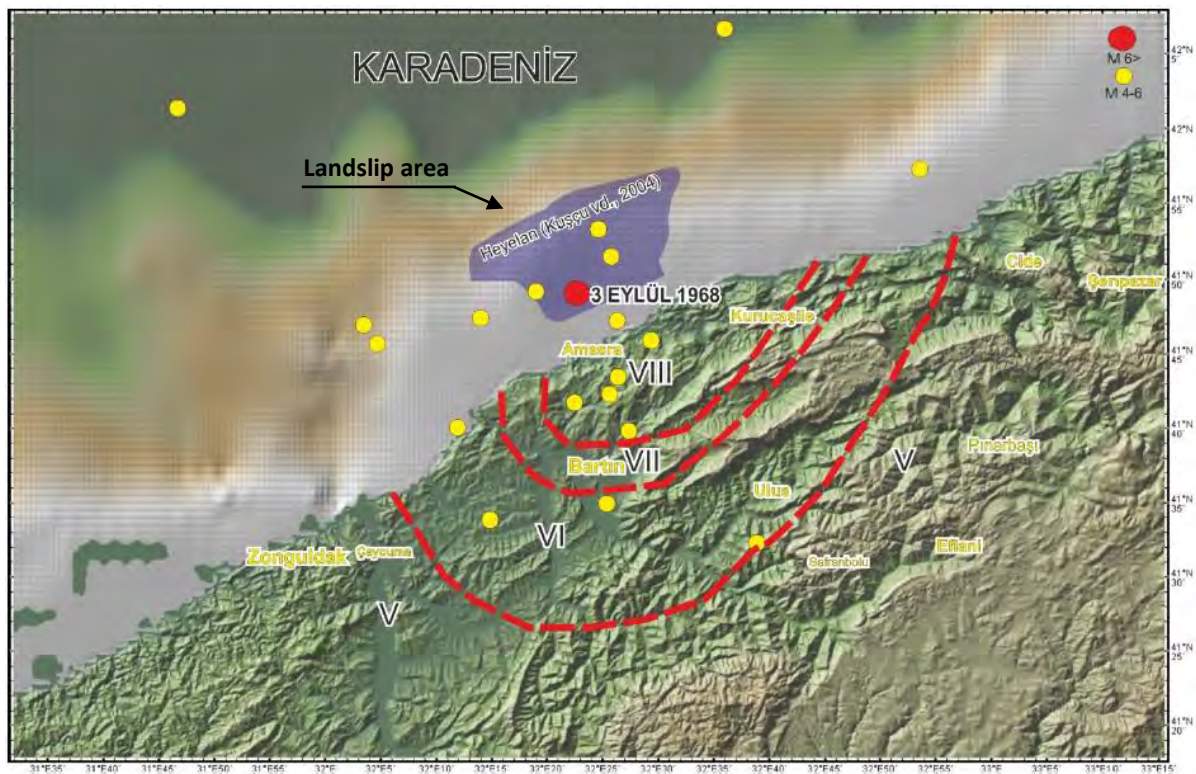

Figure 6-8: Seismic activity map of Amasra and the vicinity

### 6.2.2 Soil Characteristics and Erosion

The main soil groups found in Bartın Province are the following: (1) Alluvial Soil, (2) Colluvial Soil, (3) Red-Yellow Podzolic Soil, (4) Brown Forest Soil, (5) Gray-Brown Podzolic Soil, and (6) Brown Forest Soil without Lime. In Amasra town and its surroundings, in general, Brown Forest Soil and Red-Yellow Podzolic Soil groups are dominant (Figure 6-9).

Brown Forest Soil is composed of lime-rich matter, with horizons gradually transitioning to each other. This group of soil is dominant around Amasra and appears as the prevalent soil cover within

the Project areas. Its drainage properties are well and it is common in forests, grasslands and agricultural lands.

The second most common soil type around Amasra is the Red-Yellow Podzolic Soil, which is a group of acidic and zonal soils having a leached, light-colored surface layer and a subsoil horizon containing clay and oxides of aluminum and iron, varying in color from red to yellowish red and yellowish brown.

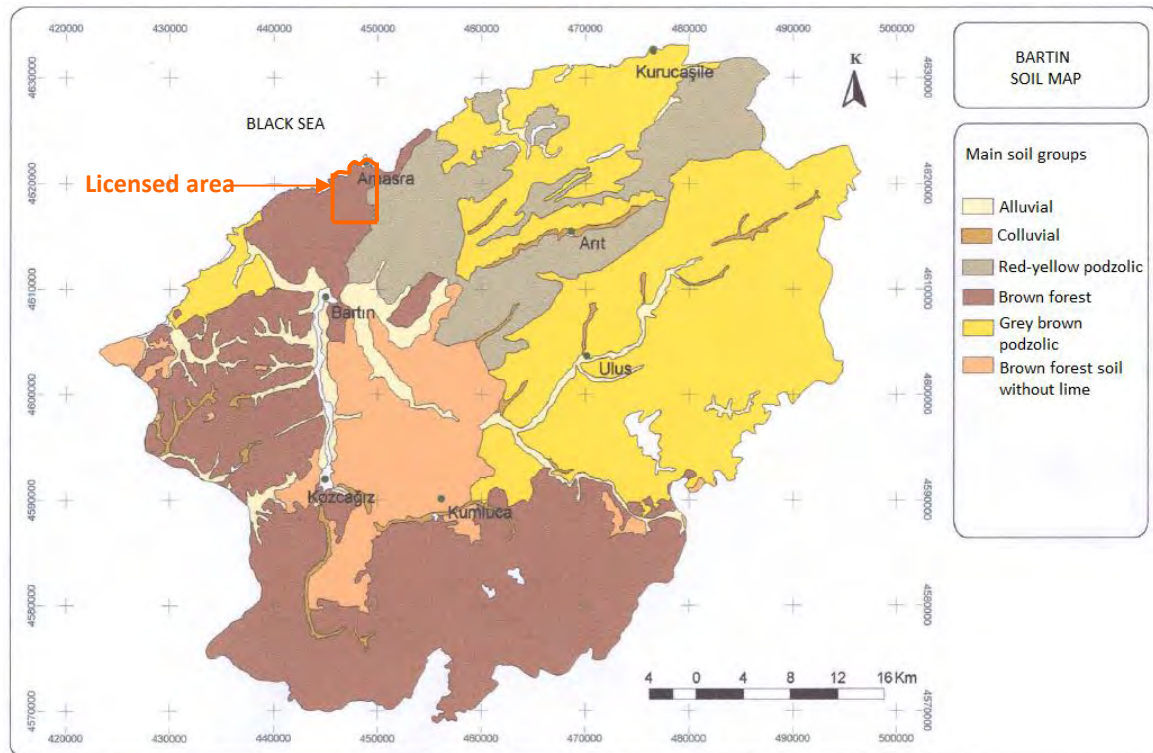

Figure 6-9: Soil classification map of Bartın Province<sup>1</sup>

Soil capability classification map of the Bartın Province (Figure 6-10) indicates that, the Project Areas remain within Class IV lands (on a scale of I to VIII, I indicating the highest and VIII the lowest cultivation capability). This class of soil capability is indicative of medium suitability of the land for agricultural use, with relatively hilly topography susceptible to erosion, shallow soils, low saturation levels and low fertility characteristics. Despite often being unsuitable for cultivating crops, these lands can generally be used for grazing purposes.

The prevalent soil erosion risk within the Project areas is identified as 2<sup>nd</sup> degree (based on a scale where 1<sup>st</sup> degree indicates the lowest and 4<sup>th</sup> degree indicates the highest erosion risk). Such assessment is based on the soil erosion classifications of the Ministry of Food, Agriculture and Livestock and is made according to an evaluation of possible extent of loss in surface soil horizons. Owing to their rigorous vegetative cover, lands within the Project licensed area are considered to have undergone a low degree of erosion, in spite of the hilly topography and intense amount of rainfall in the region.

<sup>1</sup> Bartın Province Agricultural Master Plan, December 2005

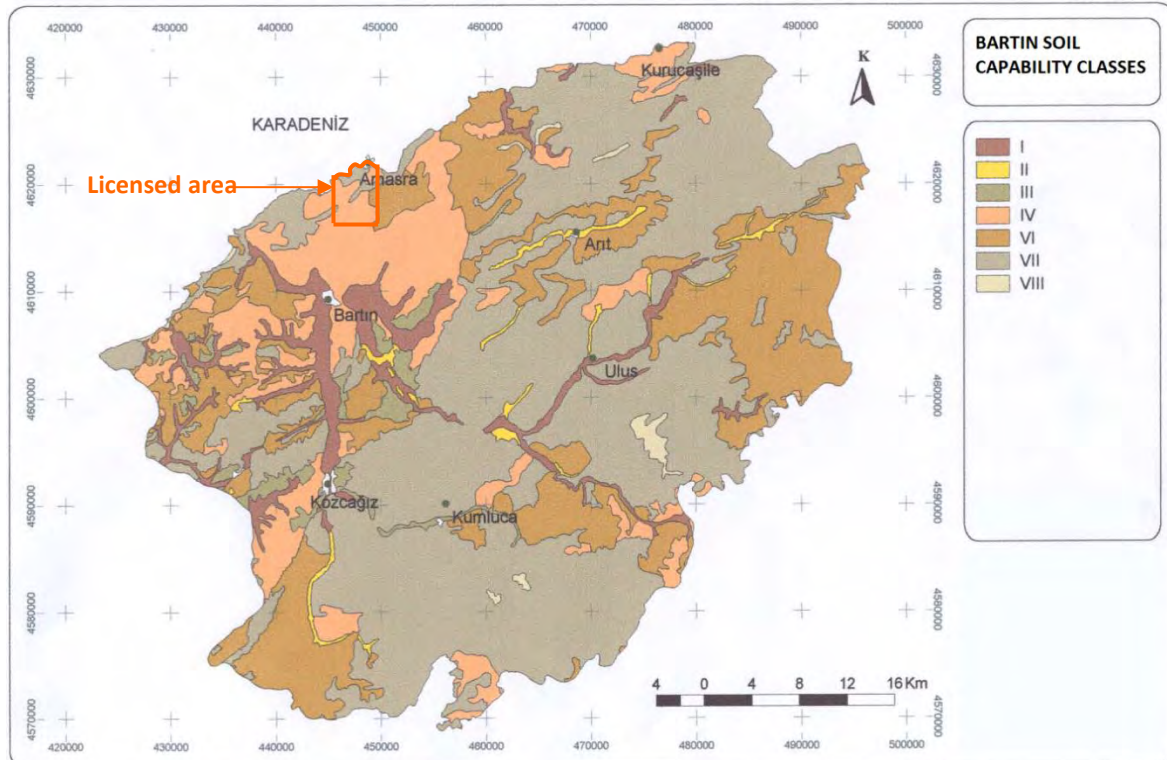

Figure 6-10: Soil capability classes of Bartın Province<sup>1</sup>

### 6.2.3 Soil Quality

Based on the predominance of agricultural and forestry land uses at the Project areas and their vicinity, the potential of encountering historical soil contamination is considered to be low. In order to document the baseline soil quality at the Project license area, several surveys have been undertaken to date and the results are summarized below.

A soil quality survey was undertaken in 2013 in order to assess the baseline soil quality near Tarlaagzi and Gomu villages. Shallow soil samples were collected by a hand auger and analysed by Segal Environmental Measurement and Analysis Laboratory (Segal). The soil sampling locations are shown in Figure 6-11 below. In order to establish baseline information regarding soil contaminants, soil samples were collected from two sampling locations, SS-A (Tarlaagzi) and SS-B (Gomu). The samples were analysed for the following parameters; Heavy Metals (Antimony, Arsenic, Copper, Barium, Boron, Mercury, Zinc, Cadmium, Chromium, Lead, Molybdenum, Selenium), Total Petroleum Hydrocarbons (TPH) and Total Organic Halogens (TOX). In addition, samples were collected from six sampling locations (SS-1, SS-2, SS-3 near Tarlaagzi and SS-4, SS-5, SS-6 near Gomu) and analysed in order to assess fertility characteristics of the soils with respect to the following parameters: pH, % Saturation, % Lime, % Salinity, % Organic Material, Phosphate and Potassium.

<sup>1</sup> Bartın Province Agricultural Master Plan, December 2005

Results of soil analysis performed by Segal were evaluated against the generic soil quality limit values set out in the RSPC. Presence of contaminants in soil may constitute a risk when the concentrations exceed these generic limit values.



Figure 6-11: Soil sampling locations (Segal study)

Analytical results are summarized and compared with RSPC limit values in Table 6-2 below. In the assessment of potential exposure with respect to TPH, TOX and heavy metals in soil, the transport pathways defined by the RSPC, i.e. “Ingestion of soil and dermal exposure”, “Inhalation of volatile pollutants in outdoor air”, “Inhalation of dust in outdoor air” and “Transport to groundwater and drinking of groundwater” have been taken into consideration. In both sampling points (SS-A and SS-B), levels of two heavy metal contaminants, Arsenic and Chromium, are detected above the regulatory limit values set by RSPC. Arsenic levels exceed the generic limit values for “soil ingestion and dermal exposure” and “transport to groundwater and drinking of groundwater”, and Chromium levels exceed the generic limit values for “inhalation of dust in outdoor air” and “transport to groundwater and drinking of groundwater”. Identification of these heavy metals at similar concentrations at the two discrete sampling locations indicates that they are likely to be naturally present in the sampled soils, rather than due to past contamination impacts.

Table 6-2: Analytical results for soil contaminants (Segal study)

Contaminant	RSPC Limit Value (mg/kg)				Concentration (mg/kg)	
	Ingestion of soil and dermal exposure	Inhalation of volatiles in outdoor air	Inhalation of dust in outdoor air	Transport to groundwater and drinking of groundwater (DF=10)	SS-A	SS-B
Antimony (Sb)	31	-	-	2	<1.25	<1.25
Arsenic (As)	0.4	-	471	3	<b>15</b>	<b>15</b>
Copper (Cu)	3129	-	-	514	16	15.5
Barium (Ba)	15643	-	433702	288	115.5	100.5
Boron (B)	-	-	-	-	45	28.5
Mercury (Hg)	23	3	-	3	0.35	0.27
Zinc (Zn)	23464	-	-	6811	39.5	41

Contaminant	RSPC Limit Value (mg/kg)				Concentration (mg/kg)	
	Ingestion of soil and dermal exposure	Inhalation of volatiles in outdoor air	Inhalation of dust in outdoor air	Transport to groundwater and drinking of groundwater (DF=10)	SS-A	SS-B
Cadmium (Cd)	70	-	1124	27	1.15	1.3
Chromium (Cr)	235	-	24	10	<b>70.7</b>	<b>62.2</b>
Lead (Pb)	400	-	-	135	13	14.5
Molybdenum (Mo)	391	-	-	14	<2.5	<2.5
Selenium (Se)	3912	-	-	0.5	<1.25	<1.25
Total petroleum hydrocarbons (TPH)	-	-	-	-	<1.58	<1.58
Total organic halogens (TOX)	-	-	-	-	58.1	131.88

Results of analysis and assessment of the soil samples in terms of soil fertility parameters are provided in Table 6-3. Soil texture analysis of collected samples classified the soils to range from loam to clayey loam, indicating favourable physical properties for plant growth. Soil samples were identified to be non-saline and within neutral to low alkaline range, thus favouring plant growth. On the other hand, organic matter contents of all sampled soils were identified to be low, below the preferred fertility level of 2%. Phosphate availability values vary based on sampling location, remaining below nutrient-sufficient levels in samples collected from around Gomu Village.

Table 6-3: Analytical results for soil fertility (Segal study)

Parameter	Sampling Locations					
	SS-1	SS-2	SS-3	SS-4	SS-5	SS-6
Saturation (%)	73 (Clay)	55 (Clayey loam)	40 (Loam)	46 (Loam)	60 (Clayey loam)	55 (Clayey loam)
pH	8.3 (Low alkaline)	7.97 (Low alkaline)	6.72 (Neutral)	6.52 (Neutral)	7.63 (Low alkaline)	7.58 (Low alkaline)
Lime (%)	3.99 (Low)	3.58 (Low)	2.89 (Low)	3.30 (Low)	3.44 (Low)	3.16 (Low)
Salinity (%)	0.012 (Non-saline)	0.009 (Non-saline)	0.007 (Non-saline)	0.007 (Non-saline)	0.014 (Non-saline)	0.014 (Non-saline)
Organic material (%)	0.33 (Very low)	0.26 (Very low)	0.35 (Very low)	0.39 (Very low)	1.22 (Low)	1.14 (Low)
Phosphate (kg/da)	1.72 (Very low)	9.39 (Sufficient)	8.93 (Sufficient)	1.26 (Very Low)	2.18 (Very Low)	0.80 (Very Low)
Potassium (kg/da)	42.65 (Sufficient)	37.00 (Sufficient)	26.28 (Low)	22.21 (Low)	203.52 (Sufficient)	182.11 (Sufficient)

A second soil investigation was undertaken at the site by Prof. Yusuf Kurucu from the Ege University which aimed to assess the physical and chemical soil characteristics within the impact area of the proposed power plant. The study identified baseline soil conditions in terms of inorganic parameters including heavy metals such as Nickel, Cadmium, Zinc, Lead, Copper and Chromium. The analysis of parameters was conducted by the Balikesir University.

Analytical results for samples taken within the license area are summarized in Table 6-4 and the sampling locations are provided in Figure 6-12 below. When compared against RSPC generic limit values for soil quality, levels of all measured inorganic parameters appear to comply with the national regulatory limits. Soil pH values range from slightly acidic to slightly alkaline, and the soils are usually of medium texture such as loam, sandy loam or clayey loam.

Table 6-4: Analytical results for soil constituents (Ege University study)

Contaminant		Nickel (Ni)	Cadmium (Cd)	Zinc (Zn)	Lead (Pb)	Copper (Cu)	Chromium (Cr)	Chloride (Cl)	Sulfur (S)	Sulfate	Fluoride (F)	pH	Soil type
RSPC Limit Value (mg/kg)	Ingestion of soil and dermal exposure	1564	70	23464	400	3129	235	-	-	-	-	-	-
	Inhalation of volatiles in outdoor air	-	-	-	-	-	-	-	-	-	-	-	-
	Inhalation of dust in outdoor air	-	1124	-	-	-	24	-	-	-	-	-	-
	Transport to groundwater and drinking of groundwater (DF=10)	13	27	6811	135	514	10	-	-	-	-	-	-
Soil Conc. (mg/kg)	A-1 (0-32 cm)	0.2	ND	1.4	0.7	0.7	ND	160.2	9.13	27.35	0.9	6.89	Loam
	A-1 (32-41 cm)	0.1	0.011	0.3	0.4	0.8	ND	185.1	11.36	34.03	1.0	7.45	Clayey loam
	A-1 (41-53 cm)	0.1	0.009	0.3	0.3	0.6	ND	308.2	7.59	22.75	1.1	8.37	Loam
	A-2 (0-18 cm)	0.2	0.056	3.9	2.3	0.6	ND	195.3	13.21	39.58	1.9	7.43	Sandy loam
	A-3 (0-9 cm)	0.3	0.020	3.4	1.2	0.6	ND	149.4	15.30	45.84	0.9	5.99	Loam
	A-3 (9-51 cm)	0.2	ND	2.6	0.5	0.6	ND	193.8	16.36	49.01	2.4	5.68	Loam
	A-4 (0-6 cm)	0.5	0.041	1.8	1.1	2.9	ND	105.1	40.91	122.59	0.5	6.74	Sandy loam
	A-5 (0-16 cm)	0.6	0.026	3.0	5.1	1.4	ND	164.8	24.20	72.50	0.6	6.54	Sandy loam
	A-6 (0-6 cm)	0.3	0.047	8.6	3.0	4.4	ND	65.0	12.23	36.64	0.9	7.24	Sandy loam
	A-7 (0-20 cm)	1.0	ND	0.7	0.9	1.5	ND	199.6	7.95	23.81	1.6	7.30	Loam
	A-7 (20-40 cm)	1.0	ND	0.5	0.7	2.2	ND	219.0	8.65	25.92	0.9	7.03	Loam
	A-8 (0-9 cm)	0.1	ND	0.6	1.2	1.8	ND	153.8	8.37	25.08	1.1	7.68	Sandy loam
	A-9 (0-26 cm)	0.3	0.023	2.5	0.9	1.6	ND	199.8	12.52	37.52	0.7	6.95	Sandy loam
	A-12 (0-32 cm)	0.8	0.038	5.0	2.5	3.6	ND	199.9	10.27	30.76	1.1	6.44	Loam
	A-13 (0-10 cm)	0.4	0.030	5.8	1.3	1.6	ND	159.8	31.65	94.84	1.1	6.70	Sandy loam
	A-13 (10-31 cm)	0.2	0.069	0.7	0.6	1.9	ND	103.9	21.09	63.19	1.3	7.83	Sandy loam
	A-14 (0-11 cm)	0.3	0.046	1.0	0.8	1.4	ND	215.0	11.18	33.49	0.6	6.59	Sandy loam
	A-15 (0-25 cm)	0.4	0.052	0.9	1.6	2.6	ND	175.0	9.66	28.94	1.1	6.97	Sandy clayey loam
	A-29 (0-12 cm)	0.7	ND	1.0	0.1	0.4	ND	208.9	19.88	59.57	0.4	5.82	Sandy clayey loam
	A-30 (0-25 cm)	1.1	0.103	2.5	3.8	1.9	0.027	201.7	25.14	75.32	0.8	6.41	Sandy clayey loam
A-33 (0-25 cm)	0.3	0.080	1.3	2.6	1.0	ND	155.1	12.90	38.65	1.2	7.65	Clayey loam	
A-34 (0-7 cm)	0.8	0.010	3.0	2.9	4.4	0.028	124.0	18.81	56.36	1.4	7.09	Sandy loam	
A-35 (0-7 cm)	1.9	0.097	4.6	5.3	2.0	ND	243.4	14.11	42.28	1.1	6.97	Loam	





Figure 6-12: Soil sampling locations (Ege University study)

## 6.3 Impacts

### 6.3.1 Impacts related to Geology and Seismicity

As a result of the underground coal mining and associated subsidence effects (i.e. gradual sinking of landforms to a lower level), a series of depressions are expected to occur across the landscape within the license area. Land subsidence occurs as a result of collapse of rock above mined area resulting in bending and breakage of overlaying strata that ultimately reach the surface, which may damage properties and agricultural activities on the land surface. The magnitude of the subsidence effect is depending on the thickness, depth and slope of the coal seam, size of the panels, geologic and topographic features of the soil and physical properties of the structures above. In general, subsidence effect of the voids that are left within the collected strata nearer the surface is more damageable although the influence area gets wider as the production level increases in the vertical direction.

The Project is proposing to use conventional longwall mining techniques to extract the coal from East, West and Southeast Production Blocks. In longwall mining, the area immediately in front of the coal face is supported by hydraulic roof supports, which temporarily hold up the roof strata and provide a working space for the shearing machinery and face conveyor. After each slice of coal is removed, the hydraulic roof supports, the face conveyor and the shearing machinery are moved forward, resulting in subsidence (Figure 6-13).

Subsidence usually refers to vertical displacement of a point, but subsidence of the ground actually includes both vertical and horizontal displacements. These horizontal displacements can in many cases be greater than the vertical subsidence. As the subsidence wave approaches a point on the surface, the ground starts to settle, is displaced horizontally towards the mined void and is

subjected to tensile strains, which build from zero to a maximum over the length of convex or hogging curvature, as shown in Figure 6-14. Generally, subsidence varies between %5 to %100 of the thickness of the coal seam.

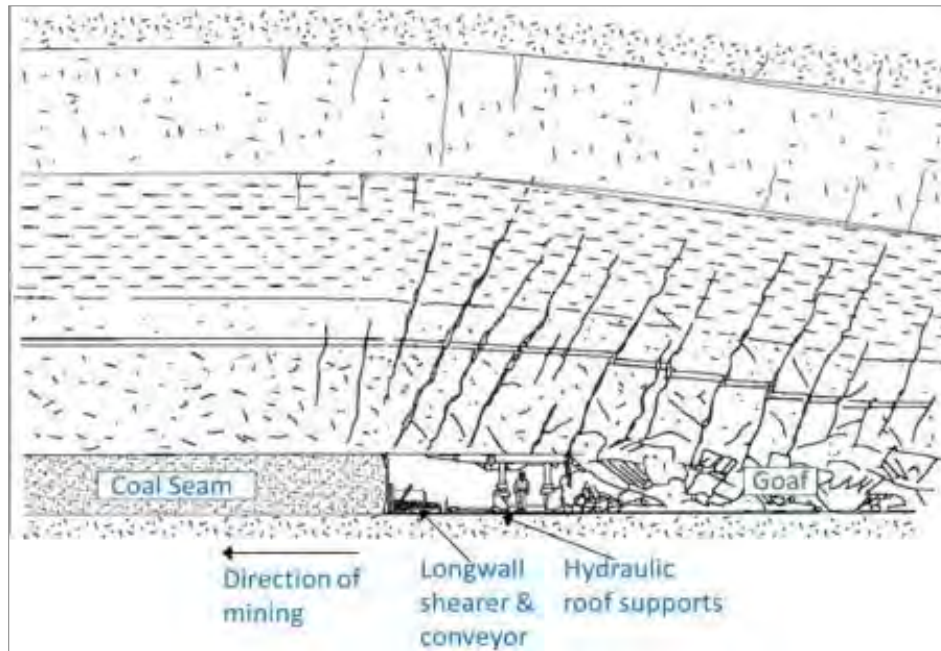

Figure 6-13: Cross-section of a typical longwall face<sup>1</sup>

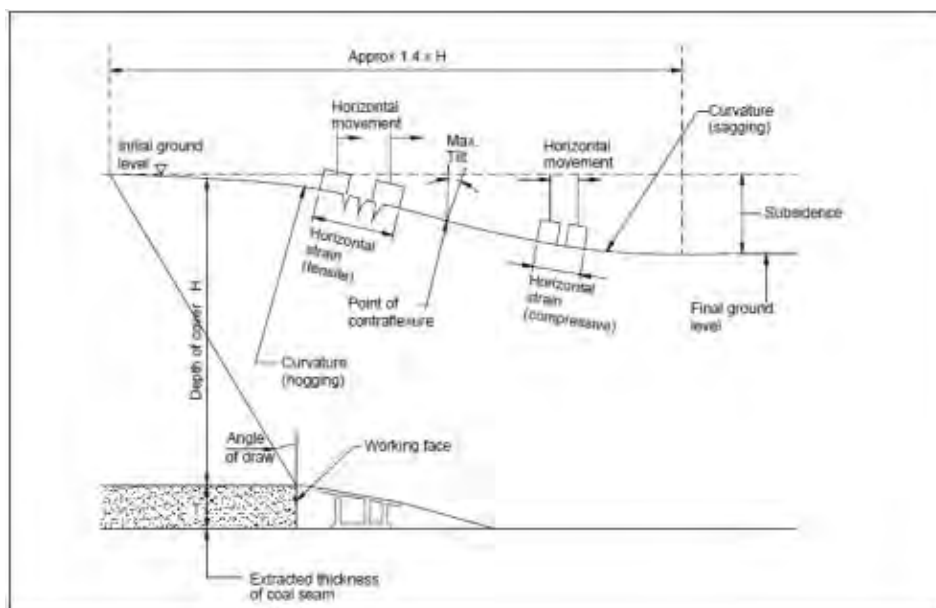

Figure 6-14: Development of a subsidence trough (to an exaggerated vertical scale)<sup>1</sup>

Previously, Turkish Hard Coal Enterprise has conducted a study for the subsidence effect around Gomu Village, resulted from their mining activities which took place much nearer to surface level (80 m-100 metres below surface) and terminated in 1987. Results of the study are given in *Annex F*.

<sup>1</sup> [http://www.minesubsidence.com/index\\_files/files/Intro\\_Longwall\\_Mining\\_and\\_Subs.pdf](http://www.minesubsidence.com/index_files/files/Intro_Longwall_Mining_and_Subs.pdf)

---

Some of the residents have been expropriated during the production and some slight structural damage observed after the closure of the mine. The buildings have been returned to the original owners later on and are still suitable to reside.

A modelling study for subsidence effect was conducted by Hattat Enerji ve Maden Ticaret A.S. As seen in Figure 6-15, a part of Bostanlar and a minor part of Kazpinari Villages are located above the East Block whereas, the rest of the Kazpinari and a part of Ugurlar Village are located above the Southeast Production Block; however, the study states that only a small portion is likely to be effected by subsidence when considered the design of the production panels. On the other hand, there isn't any settlement above the West Production Block. The coal production will take place underground at -450/-550 elevations. Since the elevations of the settlements are around +250/+350, the production depth is approximately 700/800 metres. According to the modelling results, theoretically, 54 to 64 centimetres of subsidence may occur within 8 to 10 years from the beginning of the coal production.

Additionally, according to Subsidence Engineers Handbook of National Coal Board (NCB); a set of computations were conducted and as a result, vertical subsidence is expected to be approximately 0.60 metres which cause a structural deformation of 0.07 mm/m (maximum value for buildings is 20 mm/m).

Once the coal production initiates, subsidence observation stations will be located in three different points and the geological movements will be measured constantly. By this means, the subsidence effect will be monitored and necessary precautions will be overtaken prior to underground activities start below the settlement areas.

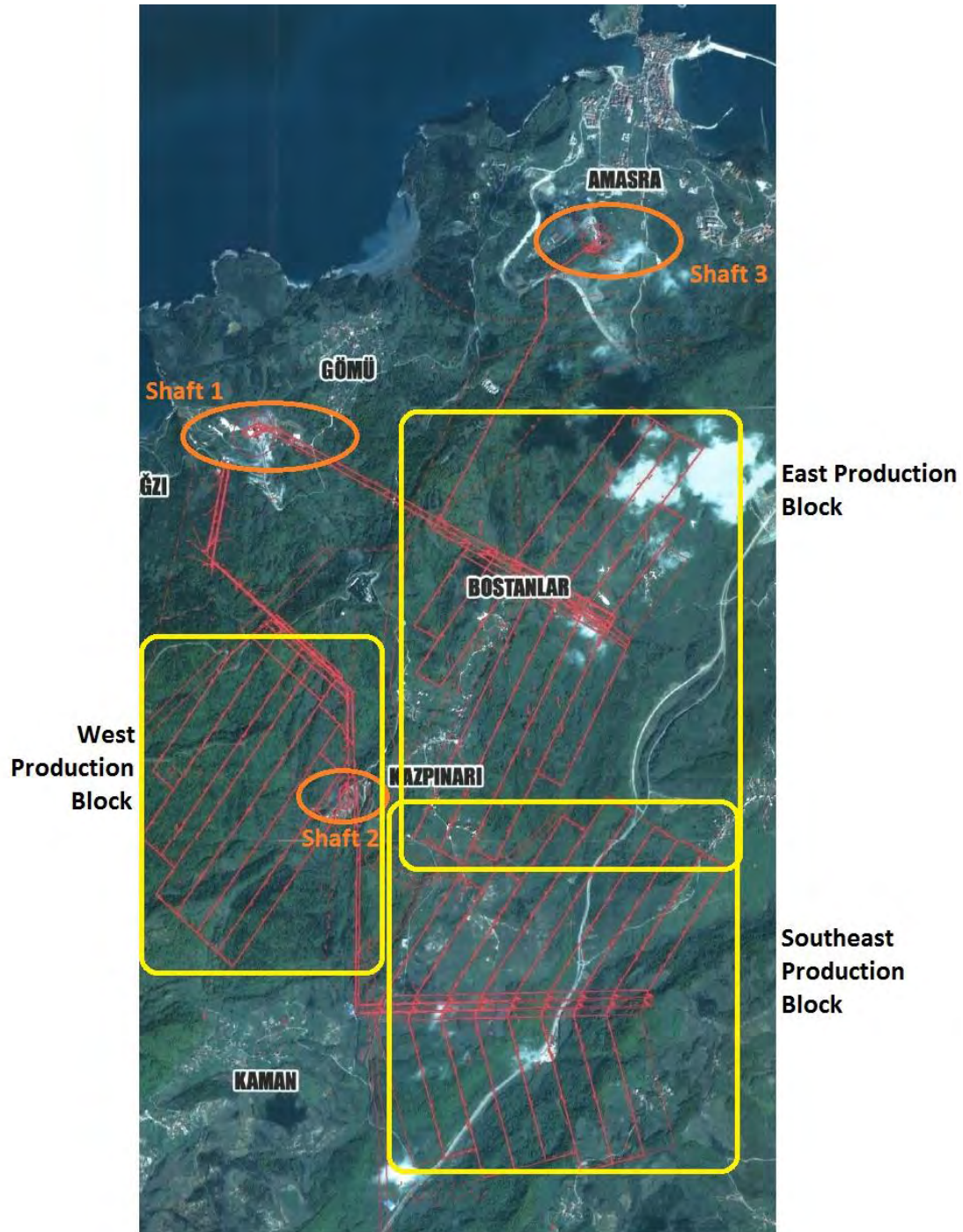

Figure 6-15: Settlement areas above coal production blocks

### 6.3.2 Impacts related to Soil

#### Direct Soil Loss

*Shaft Sites:* Direct soil loss impacts at the shaft sites will continue as long as coal extraction takes place and to a lesser degree post closure. Soil loss will be within the footprints of the shaft sites and the waste rock dump sites on which the excavation wastes have been placed. Potential downstream impacts are also likely to happen. Shaft-1 and Shaft-2 sites –with the waste rock dump sites around– are located on the forest and marginal agricultural lands (*Chapter 5: Land Use and Zoning*) and soil resources are considered as fragile and difficult to restore. The impacts at individual shaft sites are evaluated below:

- The entire footprint of the Shaft-1 site has been cleared, developed with the operational and administrative buildings and infrastructure development is still in progress. Apart from that, excavated soil and waste rock material resulting from underground construction activities are dumped on the land once-forested, with an approximate surface area of 50,000 m<sup>2</sup>, around Shaft-1. During the coal extraction, dumping of the waste rock will continue on an additional land of 65,000 m<sup>2</sup> near the shaft. The two coal washing plants (approximately on a land of 9,000 m<sup>2</sup>) proposed within the scope of the Project will also be constructed on the cleared HEMA land in Shaft-1. Therefore, the soil loss impact at Shaft-1 is considered to be major.
- The entire footprint of the Shaft-2 site has also been cleared, developed with infrastructure development such as workers' accommodation facilities, storage areas for construction equipment, waste rock carrying conveyor equipment and substations. Similar to Shaft-1, the excavated soil and rock resulting from the underground activities are being dumped on the land with an approximate surface area of 150,000 m<sup>2</sup> around Shaft-2. The soil loss impact is major; with the potential of affecting forestlands, wetlands and deteriorating some agricultural lands in the surrounding area.
- Shaft-3 is located on an urbanized area which has already been used for mining activities by Turkish Hard Coal Enterprise since 1960s. Therefore, the soil loss impact of the Project is assessed to be minor; with lesser adverse effects on forestlands and residential areas in the surrounding area.

*Spoil Dumpsites:* Direct soil loss impacts at the two spoil dumpsites of the Project will continue as long as the coal processed in the coal washing plants and to a lesser degree post closure. Soil loss will be mainly limited to the footprint of the sites proposed for spoil dumpsites. The impacts related to the Spoil Dumpsites 1 and 2 are evaluated below:

- Spoil Dumpsite-1 is located on the forestland and marginal agricultural area with an approximate surface area of 88,000 m<sup>2</sup>. The entire footprint will be cleared and utilized for spoil disposal. Therefore, the soil resource to be affected is fragile and difficult to restore. The soil loss impacts from Spoil Dumpsite-1 are assessed to be of major significance.
- Surface area of Spoil Dumpsite-2 is approximately 7,200 m<sup>2</sup> and the entire footprint will be cleared and utilized for spoil disposal. It will be located on the already cleared HEMA land. The soil loss impact is considered to be minor and may not significantly affect the land since the area is relatively smaller.

*HEMA Port Area:* Entire footprint of the proposed HEMA Port area will be cleared and utilized for infrastructure development. The loss of soil will be within the footprint of the site which is located on the forest land. Therefore, the soil resource to be affected is fragile and difficult to restore. The loss is moderate and may affect forest lands in the surrounding area. Potential downstream impacts are also likely to happen. The soil loss impact will continue as long as the construction, embankment and sloping activities take place and to a lesser degree post closure. Therefore, the soil loss from HEMA Port area is assessed to be of moderate impact.

*Conveyor System:* The loss of soil will be confined within the footprint of the overland covered conveyor belt corridor. The conveyor corridor will be of 2 metres width and the distance between the Shaft-1 and bulk cargo quay is approximately 1,000 metres. The entire footprint of route will be cleared and utilized continuously for coal transportation. The soil loss impact will continue as long as coal extraction and transportation takes place and to a lesser degree post closure. It is assessed to be of minor significance.

### *Erosion Impacts*

Impacts related to soil loss may occur due to increased erosion and landslide potential related to the removal of vegetation cover at Project areas such as shaft sites, spoil dumpsites, port area and conveyor system area as a result of site clearing during the construction and operation phases. Soil erosion is especially important in areas where vegetation has been cleared from steeper slopes and ridges, as magnitude of soil loss is potentially higher at such landscapes. According to the soil maps of Ministry of Food, Agriculture and Livestock, the erosion risk is indicated to be moderate in the Project areas.

Any action that may result in soil erosion is considered to have a permanent adverse impact on the soils and may also impact surrounding properties. During the construction of the port, slope protection area which is located behind the quay structure will be applied to prevent risks associated with landslides.

Therefore, potential erosion impacts, which are considered to be moderate, must be minimized through mitigation measures discussed in Section 6.4 during construction and operation phases of the Project. In case of long-term occurrence during operations the impacts may become major and warrant further specific mitigation measures.

### *Operational Impacts on Soil Quality*

Source of impacts related to soil quality may include:

- Spills/accidents of hazardous chemicals during development, construction and operation phases
- Leakage from fueling stations, maintenance activities and storage of hazardous materials and wastes
- Infiltration of storm water through storage areas and dumpsites
- Wastewater infiltration into subsurface
- Leaching of hazardous chemicals from storage areas and dumpsites
- Acid mine drainage generation due to exposure of mined materials to oxygen and water

- Generation of sulphates if the waste being originated during the coal processing contains sulphides

Construction activity on soils, storage of construction equipment and materials on soils, leakage of fuels and hazardous materials have the potential to affect soil and groundwater through spills of oils, fuel or other materials. If good construction practices are not applied to provide protection against soil, potential impacts are expected to range between minor to major significance depending on the duration of the spills that may range from temporary small-scale spills to continuous/long-term spills.

During operation, soils may become contaminated from spills of hazardous materials, poor management of hazardous wastes generated at the site, leakage from underground equipment and services. These spills and leakages may lead to impacts that are considered to range between minor to major depending on the spill size, nature of contaminants and impacted areas.

Potential for soil and groundwater contamination exists due to infiltration of acid mine drainage. Acid mine drainage is created when water mixes with coal and other rocks unearthed during mining, taking on toxic levels of minerals and heavy metals. Mined and refuse materials originating from the coal mining and washing processes may contain hazardous substances such as heavy metals that can leach out of storage areas, containers or dumpsites, contaminating surface and ground water. Improper design and lack of proper drainage systems at the mine sites may result in infiltration of storm water through storage areas and dumpsites pollute soil and groundwater. Improper storage and discharge of domestic and industrial wastewater also have the potential to pollute soil and groundwater. Potential impacts due to leaching and infiltration of hazardous substances are expected to range between minor to major, depending on the extent and duration of such events.

The Project will therefore be designed with the necessary protection systems against spills, leaching and infiltration of hazardous materials and wastewater generated at the site. Applicable mitigation measures are discussed in Section 6.4.

#### **6.4 Mitigation Measures**

Mitigation measures to avoid and/or mitigate the predicted impacts during the construction and operation phases will include the following:

- All contractors will be required to adopt good construction site practices for protection of soils and to follow the relevant IFC Guidelines.
- The Project will be designed, constructed and operated in accordance with the Turkish and international regulations and standards and therefore, risks will be as low as technically and financially feasible.

Specific measures for protection against geological and seismic risks will include the following:

- Monitoring will be undertaken on a regular basis from three points to measure subsidence movements. Such data will be used to assist with making future subsidence predictions and compare predictions with observations. Infrastructure and occupants to be impacted by land subsidence will be relocated in well advance of predicted impacts, as necessary.

- Below the determined risky areas, pillars between the production panels will be adjusted accordingly.
- To minimize the subsidence effect, voids that are left within the collected strata will be stowed.
- If the damage is unavoidable, the would-be affected areas will be expropriated.
- The Project will be designed, constructed and operated for protection against seismic activity. Systematic monitoring and regular review of geotechnical stability data will be carried out. All structures including waste rock and spoil dump sites and underground excavations will be designed such that geotechnical risks are appropriately managed throughout the entire mine cycle.
- Accurate assessment of worksite safety from rockfall and/or landslide will be conducted. Particular attention will be given after heavy rainfall, seismic events and after blasting activities. Risks will be minimized by appropriate bench and pit slope design, blast pattern design, rock scaling, protective berms and minimizing traffic.

Specific measures for protection against soil loss and erosion risks will include the following:

- A Site Rehabilitation Plan will be developed and implemented, addressing both interim and final land rehabilitation requirements including topsoil management (top soil stripping, stockpiling, and application procedure), soil stabilization, erosion potential and control and afforestation activities.
  - All usable soil material will be stripped and stored for rehabilitation. The depth of stockpiling should be determined so that it does not cause landslides. Soil will be stockpiled separately from any underlying spoil material and cross contamination will not be allowed
  - The soil and spoil stockpiles will be stabilized and restricted on the downslope side to avoid erosion of the stockpiles by water runoff. The stockpiles will be re-vegetated using indigenous grass seeding to ensure stability as well as possible organic material accumulation.
- Vegetation removal will be minimized to the extent possible. Clearing of vegetation in any given area will only occur immediately before construction is due to commence in that area. Medium to long-term exposure of open bare soil surfaces will be avoided, so as to avert the risk of water runoff induced erosion. Where surface vegetation is removed (for example to create roads or access ways), measures will be put in place so as to prevent excess surface water flow (inclusion of cut-off channels, culverts etc.).
- Erosion controls relative to possible soil erosion from vehicular traffic, construction and mining activities will be applied (e.g. jute netting, silt fences and check dams).
- Operations will avoid creating excessive slopes during excavation and blasting operations.

Specific measures for protection of soil quality will include the following:

- Spoil and waste rock will be disposed in dumpsites designed in accordance with applicable regulations and located in approved areas.
- Coal storage areas will be designed to prevent impacts to soil and water resources and will be paved with the associated leachate collection systems to segregate potentially contaminated storm water, which will be transferred to the wastewater treatment unit if



the characteristics of potentially contaminated storm water do not meet the discharge criteria specified in the relevant national regulations.

- A Soil Contamination Management Procedure will be included in the Emergency Preparedness and Response Plan. The procedure will ensure that any spillages from handling fuel and other hazardous liquids will be immediately contained on site and the contaminated soil will be removed from the site for suitable treatment and/or disposal. The Procedure will also be comprised of the followings;
  - All staff and subcontractors will be required to report any incidents and these will be subject to investigation; also remedial and preventive actions will be taken as needed.
  - Spill response kits including absorbent materials suitable for the materials will be present on site. These will be kept at designated areas with specific instructions for their use. Site staff will be trained on the use of spill kits.
  - Response to the spill will be made as fast as possible. Contaminated materials will be collected and sent to appropriate disposal facilities.
- Catch basins, drainage ditches and culverts will be cleaned regularly.

## 6.5 Residual Impacts

With the implementation of mitigation measures mentioned above and in other relevant chapters (i.e. *Chapter 7: Hydrology and Hydrogeology* and *Chapter 8: Material Resources and Waste Management*, the residual impact on soil and groundwater is estimated to be moderate.

## 7.0 HYDROLOGY AND HYDROGEOLOGY

### 7.1 Scope

Potential impacts on the quality and the quantity of the surface and groundwater environment during construction and operation of the Project were identified as areas of concern during the scoping study. Baseline information was gathered for the water resources of the region and Project area. The main information sources for the baseline conditions were as follows:

- Bartın Provincial Environmental Status Report, 2011
- 1/25.000 scaled Bartın and Bartın Coastal Region Sub-Regional Planning Zone Environmental Plan, 2013
- Research and Development Study for Sustainable Environmental Investments – Environmental Impact Assessment of Thermal Plant on Surface and Groundwater by ENVIS, July, 2012
- Hydrogeological and Geological Characteristics of Southwest Amasra - Report by ENVIS Energy and Environmental Systems Research Development Ltd. (ENVIS), February, 2012,
- Literature survey

The significance criteria that were used for assessing impacts on surface water and groundwater environment are presented below.

Impact Significance	Description
Negligible	<ul style="list-style-type: none"> <li>- Contamination through site runoff and ground infiltration through leachate from excavated soils/stockpiles, construction materials (such as liquid cement, lime), spills of hazardous materials/wastes during construction and operation that are temporary in nature and that do not degrade the existing surface water runoff as well as the groundwater quality</li> <li>- Use of surface water and groundwater resources as source of water supply during construction and operation which would have negligible impact on the availability of these resources (&lt;1%) but still not to impact existing uses of these as water resources for other stakeholders</li> </ul>
Minor	<ul style="list-style-type: none"> <li>- Contamination of surface water runoff from excavated soils/stockpiles, construction materials (such as liquid cement, lime), spills of hazardous materials/wastes during construction and operation that are temporary in nature and that degrades the surface water runoff quality (&lt;10%)</li> <li>- Contamination of groundwater from soils/stockpiles, construction materials (such as liquid cement, lime), spills of hazardous materials/wastes during construction and operation that are temporary in nature; impacts cause background levels increase but remain below the generic risk levels for all sites (levels provided in Turkish Regulation on Soil Pollution Control and Point Source Contaminated Sites)</li> <li>- Use of surface water and groundwater resources as source of water supply during construction and operation which would have minor impact on the availability of these resources (&lt;10%) but still not to impact existing uses of these as water resources for other stakeholders</li> </ul>
Moderate	<ul style="list-style-type: none"> <li>- Contamination of surface water site runoff from excavated soils/stockpiles, construction materials (such as liquid cement, lime), spills of hazardous materials/wastes during construction and operation that are temporary in nature and that degrades the existing water quality (&lt;50%)</li> <li>- Contamination of groundwater from soils/stockpiles, construction materials (such as liquid cement, lime), hazardous materials and oil spills during construction and hazardous wastes and materials spills during operations;</li> </ul>

Impact Significance	Description
	<p>impacts cause background levels to be below the long-term cancer and hazard risk (levels provided in Turkish Regulation on Soil Pollution Control and Point Source Contaminated Sites)</p> <ul style="list-style-type: none"> <li>- Rainfall events causes overflow of nearby surface water drainage components causing flooding of the site without damage to facilities</li> </ul> <p>Use of surface water and groundwater resources as source of water supply during construction and operation which would have moderate impact on the availability of these resources (&gt;10%) but still not on existing uses of these as water resources for other stakeholders</p>
Major	<ul style="list-style-type: none"> <li>- Contamination of surface water site runoff from excavated soils/stockpiles, construction materials (such as liquid cement, lime), spills of hazardous materials/wastes during construction and operation that are temporary in nature and that degrades the existing water quality (&gt;50%)</li> <li>- Contamination of groundwater from soils/stockpiles, construction materials (such as liquid cement, lime), hazardous materials and oil spills during construction and hazardous wastes and materials spills during operations; impacts cause background levels to above the long-term cancer and hazard risk (levels provided in Turkish Regulation on Soil Pollution Control and Point Source Contaminated Sites)</li> <li>- Use of surface water and groundwater resources as source of water supply during construction and operation which would have impacts on the availability of these resources for other stakeholders</li> </ul>

## 7.2 Existing Environment

### 7.2.1 Water Balance

The average meteorological data from 1975 through 2005 for the Amasra district is provided in Table 7-1. The average annual temperature for Amasra is 13.5 °C. December, January, February and March are observed to be the coldest months; whereas June, July, August and September are the warmest months of the year. Annual precipitation is measured as 996.7 mm, of which 29% is measured in winter, 26% is in spring, 21% is in summer and 34% is in fall.

Table 7-1: Amasra District meteorological data

	Months												Yearly
	Jan	Feb	Mar	Apr	May	Jun	Jul	Aug	Sep	Oct	Nov	Dec	
Temperature (°C)	6.3	5.8	7.3	10.8	14.8	19.4	21.8	22.0	19.1	15.4	11.5	8.2	13.5
Precipitation(mm)	104.8	67.8	66.0	51.1	43.1	66.1	63.6	81.3	99.3	119.2	114.8	119.6	996.7
Duration of Sun (hr/day)	2.55	3.42	4.5	5.3	7.17	9.5	9.95	9.35	7.68	5.57	3.65	2.57	5.9
Relative Humidity (%)	69	69	71	72	76	74	75	75	71	72	68	68	72
Wind Speed(m/s)	5.4	5.5	5.1	4.5	4.1	3.9	4.3	4.4	4.5	4.9	5.1	5.8	4.8

Penman Method is used to calculate water balance sheet by using meteorological information (Table 7-2). Annual potential evaporation was calculated as 937.6 mm. Of this amount, 813.3 mm of annual precipitation is natural evaporation while the remaining 183.4 mm mixes with the surface water as surface runoff. The remaining 18.4 % of the annual precipitation is surface infiltration. The evaporation rate is much lower in the low-wind area between Bartın and Amasra and annual

potential and uncorrected (real) evaporation is 473.1 mm. Annually transported precipitation volume is calculated as 523.6 mm. Therefore, it is concluded that the transported precipitation volume that might have surface infiltration as potential groundwater source potential is 52.5 % of the total annual precipitation.

Table 7-2: Amasra District meteorological balance sheet

Meteorological Balance Sheet													
Method: Penman						Groundwater Reserve Capacity (mm): 100							
Station: Amasra (1975 – 2005)													
	Months												
	Jan	Feb	Mar	Apr	May	Jun	Jul	Aug	Sep	Oct	Nov	Dec	Yearly
Temperature (°C)	6.3	5.8	7.3	10.8	14.8	19.4	21.8	22.0	19.1	15.4	11.5	8.2	13.5
Potential Evapo-transpiration (mm), ETP	42.4	50.3	58.2	71.9	87.6	115.4	133.1	121.5	92.0	64.0	49.6	51.6	937.6
Precipitation (mm), P	104.8	67.8	66.0	51.1	43.1	66.1	63.6	81.3	99.3	119.2	114.8	119.6	996.7
P-ETP (mm)	62.4	17.5	7.8	-20.8	-44.5	-49.3	-69.5	-40.2	7.3	55.2	65.2	68	59.1
Groundwater Reserve (mm)	100	100	100	79.2	34.7	0.0	0.0	0.0	7.3	62.5	65.2	100	-
Uncorrected ETP (mm)	42.4	50.3	58.2	71.9	87.6	100.8	63.6	81.3	92.0	64.0	49.6	51.6	813.3
Water Shortage (mm)	0.0	0.0	0.0	0.0	0.0	14.6	69.5	40.2	0.0	0.0	0.0	0.0	124.3
Water Excess (mm)	62.4	17.5	7.8	0.0	0.0	0.0	0.0	0.0	0.0	0.0	62.5	33.2	183.4
Flow (mm)	47.3	32.4	20.1	10.1	5.0	2.5	1.3	0.6	0.3	0.2	31.3	32.2	183.2
Flow Shortage relative to P (mm)	57.5	35.4	45.9	41.0	38.1	63.6	62.3	80.7	99.0	119.0	83.6	87.4	813.4

## 7.2.2 Groundwater Resources

### Hydrogeological Framework

The regional stratigraphy consists of Palaeozoic aged, fractured, partially dolomitic limestone formation previously described in *Chapter 6: Geology, Soils and Contaminated Land*. The generalized stratigraphy is shown in Figure 7-1. The geological structure comprises of Palaeozoic, Mesozoic and Cenozoic (Quaternary) aged units. Figure 7-2 shows the hydrogeological strata of importance for groundwater resources assessment.

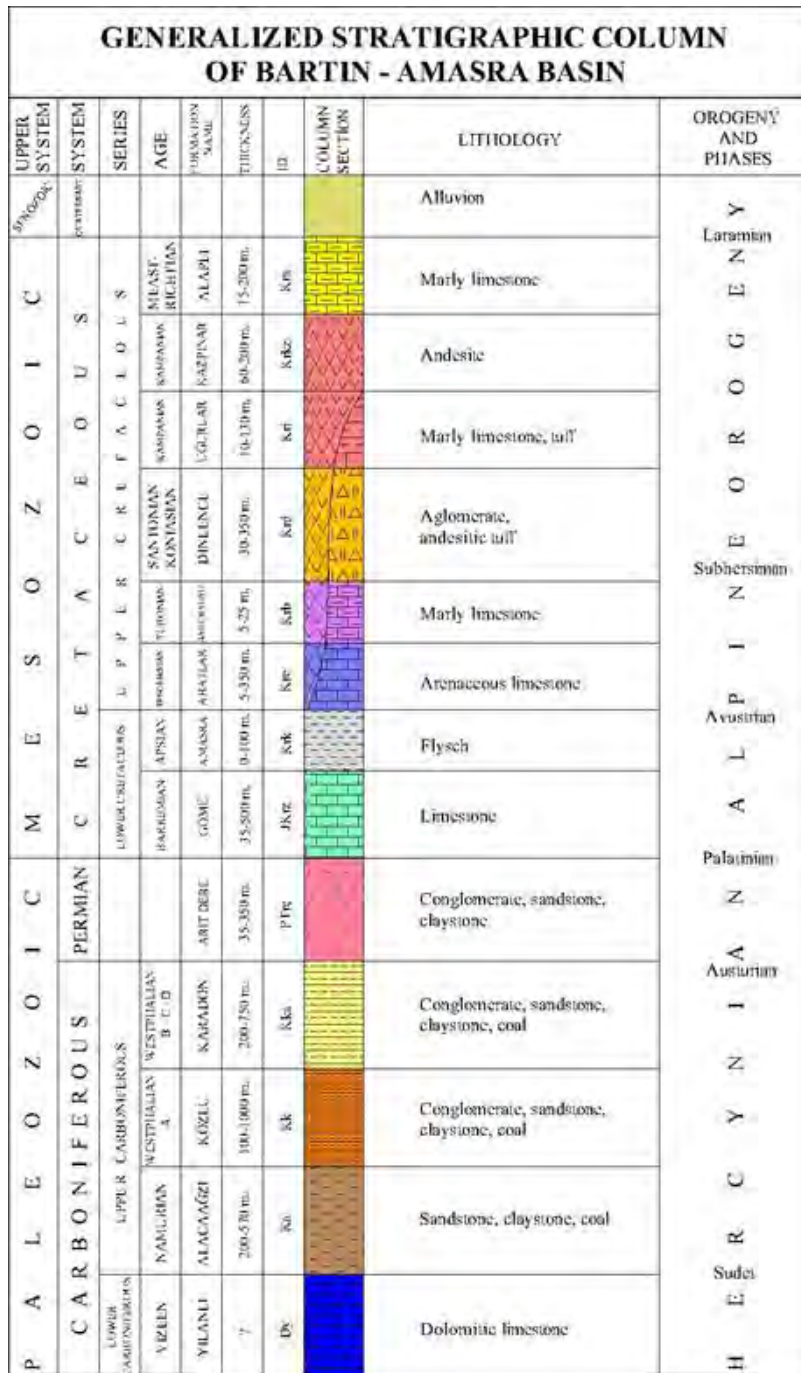

Figure 7-1: Generalized stratigraphic column of Amasra basin

Palaeozoic aged units are composed of Carboniferous and Permian aged formations. The Carboniferous aged formations contain coal bearing units and they -from bottom to top- are as follows: Yilanli formation (Devonian-Visean), Alacaagzi formation (Namurian), Yilanli formation, Kozlu formation (Westphalian A) and Karadon formation (Westphalian BCD). The Palaeozoic clastic rocks are generally impermeable, but some parts of it can be classified as poor / very poor aquifer. Carboniferous contains units of clay, sandstone, conglomerate, siltstone and shale. In the boreholes, it was seen that there were a large number of clay layers reaching a total thickness of 10-40 m between overburden and coal seams. These units are intercalated as shown continuously so vertical permeability has not developed. Coal units have not been fed from surface water at any point since they do not outcrop in the field.

Mesozoic aged formations lay on Palaeozoic aged formations by transgression. Upper Cretaceous aged formations lay on Lower Cretaceous as discordant. The most important aquifer (water bearing formation) of Upper Cretaceous sequence is the Santonian andesite, which is a confined aquifer. According to taken information from boreholes, aquifer is just located in the west side of the coal field. Figure 7-2 shows that the aquifer is fed from the exposures of the andesite. As mentioned earlier, the most important aquifer has been occurred in the overburden by much fractured andesite.

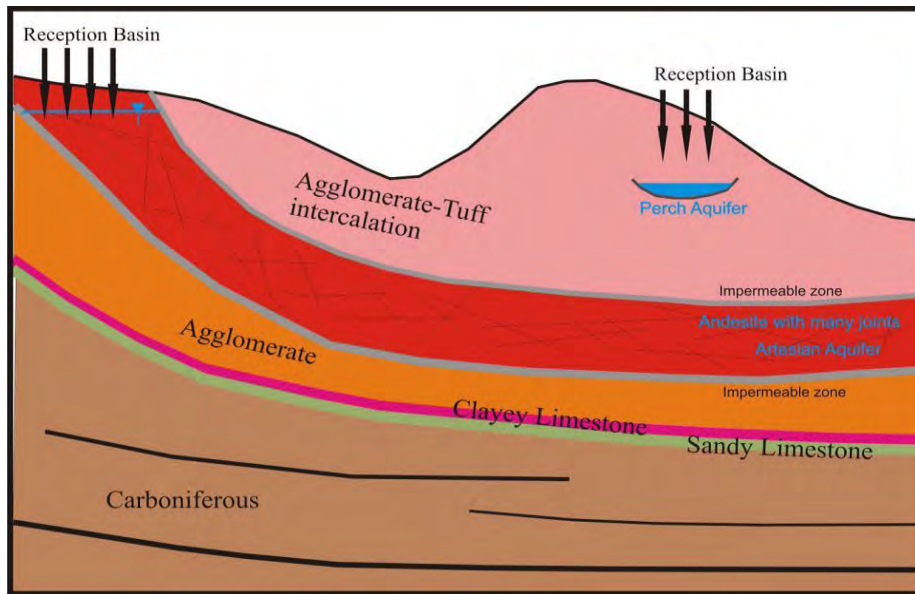

Figure 7-2: General cross-section of Amasra hard coal basin formation and aquifer system

Lower Cretaceous aged limestone consists of impermeable sand and weak carstification of sparitic and upper layered limestone observed in only certain areas. This micritic limestone, fractured andesite and tuffs are located above Cenomanian aged sandstone layer. These are localized under groundwater-bearing sections. Marl, sandstone and shale strata following layered limestone is impermeable and does not contain any groundwater. This limestone formation is highly carstic and very permeable as shown in example of Figure 7-3. The limestone that is aged Barremian and Cenomanian represent aquifer consists of seconder porosity and therefore some fractures, joints and vugs. Joints and vugs of these formations are filled with clay and calcite veins. For this reason these have little amount of water.



Figure 7-3: Carstic water outlet in the west of Delikli Cape

Carstification in limestone is the result of the reaction of rainfall that has acidic characteristics with the calcium carbonate as being the main component of limestone. Rainfall has its acidic characteristics by forming carbonic acid (weak acid with pH 5.5) via absorbing carbon dioxide in the atmosphere. Rainfall erodes limestone by reacting with calcium carbonate until rainfall neutralizes its acidic characteristics. At the Project site, carstification is observed mostly on the layers close to the surface. In addition, there are various numbers of medium sized, shallow subsea level caves without vertical branches along sea shore.

#### Groundwater Framework

A number of groundwater wells are present in the Project area. Water level measurements as well as groundwater sampling have been conducted in the past which was used in this section of the report. The shallow wells in the project area are shown in Figure 7-4; groundwater levels are around 2 m below ground level which is close to the surface.

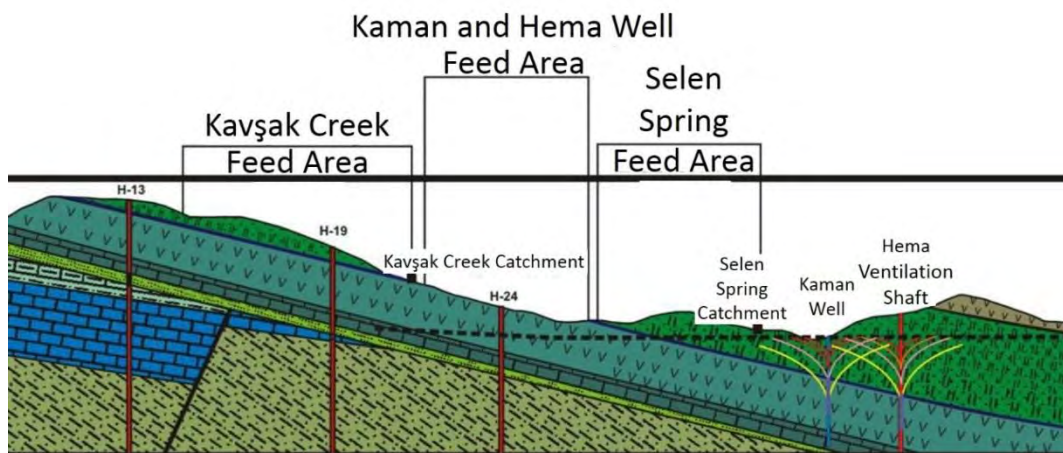

Figure 7-4: Geological – hydrogeological relationship of wells HEMA2, HSK1 and 13 with Kavşak Creek and Selen Spring.

Groundwater wells HSK1, Well 13 and HEMA2 represent deep wells and all have piezometric levels representative of the fractured andesite in the confined aquifer. The fractured andesite aquifer at well HEMA2 starts at +20 m and the water level increases up to +110 m. The Well 13 near Kaman Village forms an artesian flow and flows out of the well. In 1985, a groundwater well, specified as Well no.33151, was developed by General Directorate of State Hydraulic Works between Kazpinar and a military radar center in order to provide water to Amasra Hard Coal Enterprises. The well taps the pressured aquifer in the fractured andesite; the static level was measured as 14 m with the piezometric level of approximately +205 m above sea level. Other wells installed between 1972 and 1979 (Wells no.17036, 19969, 20089 and 25614) are located near the Bartın Creek. The static level in the wells was noted between 50 – 60 m. Selen Spring, well-known Kavsak Creek discharge from the north of the tuff and loose sandstone stratum and just above the thin plated marn limestone stratum. Groundwater sourced from above the sandstone and tuff strata (where the Kavsak Creek water discharges) differs from groundwater of Kaman Creek and HEMA Well water based on its low electrical conductivity.

The Kaman Creek and HEMA well water are fed by fractured and fragmented andesite on the creek bed located just south of Kavsak Creek and hence elevated up to +100 m as a pressured aquifer, Similar to Kaman Creek and HEMA Well water, Selen Spring is sourced from tuff and loose sandstone strata and surrounding hills. All of water resources in the vicinity of Kazpinar are fed from upper andesite or loose sandstone – tuff strata. The feed area of Selen Spring, Kavsak Creek and Well 13 is indicated in Figure 7-5 and Figure 7-6 below. The wells HEMA2, HSK1 and 13 are therefore fed by the same pressured aquifer of Upper Cretaceous – Santonian aged andesite – agglomerate shown in Figure 7-4. Aquifer is pressured due to the upper impermeable marn layer. All three wells are hydraulically connected and reflect similar chemical characteristics. As a result, groundwater pumping from any of HSK1 and HEMA2 may affect drinking water well of Kaman Village.

The relative efficiency of the well was calculated as 0.12 L/sec/m and transmissibility of the well was estimated as 20 m<sup>2</sup>/day. Since fractured andesite aquifer has a depth of 80 – 100 m, hydraulic conductivity or permeability was calculated as 0.2 m/day (or 2.3x10<sup>-6</sup>) and the aquifer is classified as weak aquifer based on its permeability data.

Similar to above mentioned historical information, a second pumping test performed at the Well no.665 (Well 13) where the water level dropped to 79 m under 6 L/sec pumping rate. Relative efficiency of the well was estimated as 0.08 L/sec/m. Similar results were obtained at well no.33151 and it is concluded that the subject well is a weak aquifer with fractured andesite aquifer.

Drawdown cones are formed as a function of pumping rate (Q), hydraulic characteristics of aquifer or transmissibility (T), storage factor (S) and time (t) for each well. A pump test was performed at the well no.33151 in the past where the water level dropped 34 m from a 4 L/sec pumping rate.

Turkish Water Pollution Control Regulation (WCPR) defines Mandatory Protection Zone (300 meters wide strip from the maximum water level of the drinking and utility water reservoir), Short Distance Protection Zone (700 m wide strip from the border of Mandatory Protection Zone), Medium Distance Protection Zone (1 km wide strip from the border of Short Distance Protection Zone) and Long Distance Protection Zone (remaining area of the watershed); in order to identify the principles for pollution control in the water basins that provide potable and utility water and identify measures to be undertaken.



With a recommendation of Ministry of Forestry and Water Affairs, 23<sup>rd</sup> Regional Directorate of State Hydraulic Works, Kavsak Creek, Selen Spring and Kaman Village drinking water well (13) indicated in Figure 7-6 near Shaft-2 of the Project are specified within Mandatory and Short Distance Protection Zones in 1/25.000 scaled Bartın and Bartın Coastal Region Sub-Regional Planning Zone Environmental Plan, accepted on 12.05.2009.



Figure 7-5: Area map showing groundwater sampling points, 'Mandatory and Short Distance Protection Zones' and the feed area of Selen Spring, Kavsak Creek and Well 13 including HEMA Port

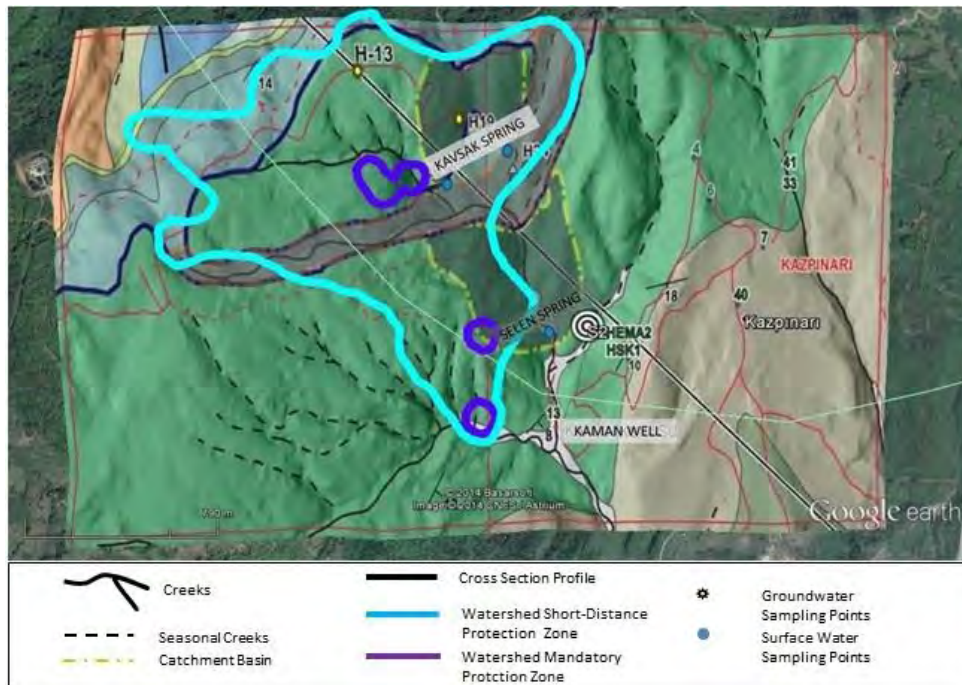

Figure 7-6: Area map showing feed area of Selen Spring, Kavsak Creek and Well 13, 'Mandatory and Short Distance Protection Zones' and reference points to HEMA Wells

Any construction is prohibited in Mandatory Protection Zones, except drinking and utilization water projects and requisite sewer systems of the already existing facilities. The region is expropriated and surrounded by fences if necessary. Besides, any construction related to tourism, housing and

industrial activities and all kind of excavation activities or solid waste storage are prohibited in Short Distance Protection Zone.

### Groundwater Quality Assessment

The groundwater quality was assessed by sampling twenty one points in the vicinity of the Project. The location of subject sampling points as shown in Figure 7-7 and Figure 7-8, according to study report of Hydrogeological and Geological Characteristics of Southwest Amasra –Report by ENVIS Energy and Environmental Systems Research Development Ltd. (ENVIS), February, 2012. Identification, coordinates and elevation of sampling points are listed in Table 7-3 and some of sampling points are shown in Figure 7-7.

Twelve samples were taken from springs or fountains connected to springs (considered as groundwater), four water samples from groundwater wells of different depths; one sample from drainage water out of HEMA ventilation shaft, three samples from surface water (creek) and one sample from Amasra municipal water (sourced by Ulupinar Spring approximately 30 km off of Amasra) were collected for a total of twenty one samples.

Table 7-3: Sampling identification and coordinates of groundwater sampling points

Sampling Identification Name/Number	X (m)	Y (m)	Elevation (m)	Source
<b>Groundwater</b>				
<b>Groundwater Springs</b>				
KVS (HEM 2)	445909	4617228	243	Spring water from Kavsak Creek
1	446468	4618850	140	Fountain water connected to a spring
2	446691	4620025	100	Fountain water
4	447015	4617331	271	Fountain water connected to a spring
6	447074	4617150	253	Water from Sukru Acar Fountain
7	447359	4616980	226	Fountain water connected to a spring
29	444967	4618620	90	Water from Nigar Verdi Fountain
30	444820	4618531	101	Water from Tarlaagzi Spring
37	446884	4620077	119	Fountain water connected to a spring
40	447234	4616730	225	Fountain water connected to a spring
41	447511	4617274	210	Spring water from a spring
44 (HEM6)	448219	4616997	177	Spring water from Pasa Creek
<b>Groundwater Wells</b>				
HEMA2 (HEM4)	446630	4616521	181	Drainage water from HEMA ventilation shaft with 1.3 m <sup>3</sup> /hour flow rate
HSK1 (HEM1)	446654	4616625	190	Groundwater from HEMA well
13 (HEM7)	446310	4616218	98	Groundwater from a well near Kaman Village
31 (HEM8)	447266	4615613	158	Groundwater from privately owned (sink) well
33	447489	4617201	208	Groundwater from privately owned (sink) well
<b>Surface Water*</b>				
KVSD	446133	4617404	313	Surface water in the vicinity of Kavsak Creek
42	447511	4617274	210	Surface water from Camasir Creek
43	446337	4616268	101	Surface water from Kaman Creek
<b>Municipal Water</b>				
45 (HEM5)	Sampled from potable city water			Drinking water from municipal water supply at Ulupinar

\*Surface water points are included; as they are discharge locations to groundwater flow network.

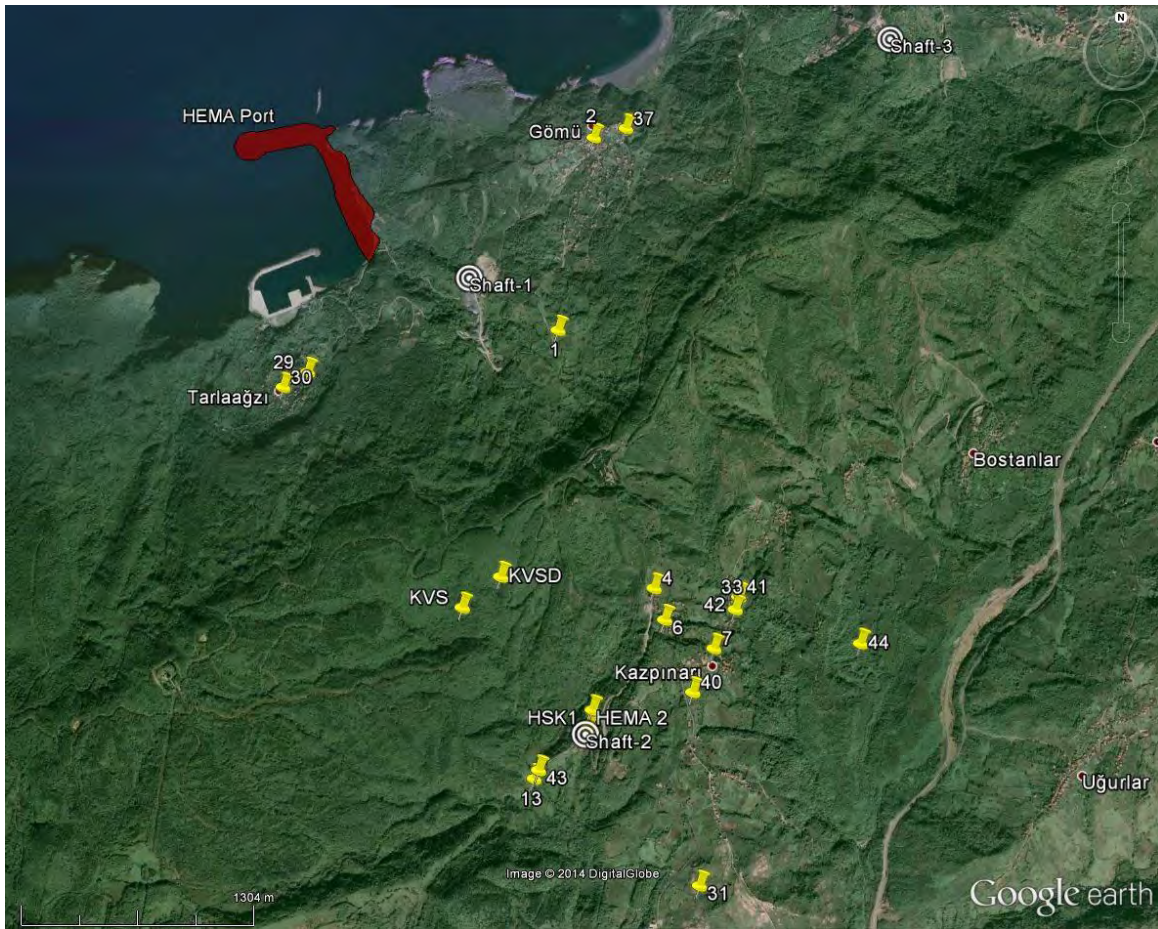

Figure 7-7: Location map of groundwater sampling points in relation to Project Shafts 1, 2 and 3

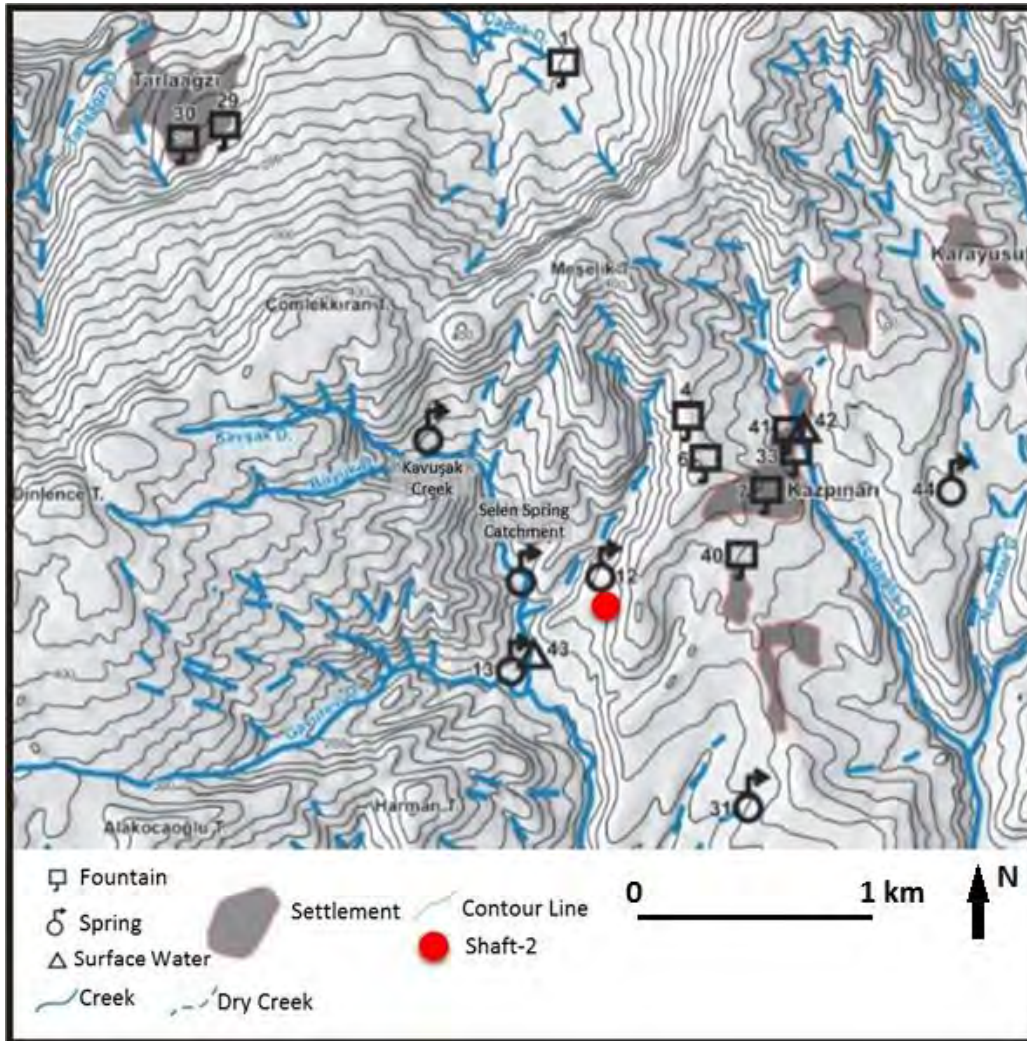

Figure 7-8: Groundwater sampling points location map



Figure 7-9: Some of the water resources included in the study

### Groundwater Quality

Groundwater samples were analyzed at an internationally accredited laboratory ACME Canada and results are listed in Table 7-4 through Table 7-6. Samples from groundwater wells and springs are

classified in accordance with the Turkish Regulation on 'Water Intended for Human Consumption (WIHC)' published in Official Gazette date/no: 17.02.2005/25730.

Table 7-4: Groundwater samples and laboratory analysis results, February, 2012

Water Quality Parameters	Sample Identification							Drinking Water Quality Parameter	
	HSK1 (HEM1)	KVS (HEM 2)	HEMA2 (HEM 4)	45 (HEM5)	44 (HEM6)	13 (HEM7)	31 (HEM8)		
<b>General Parameters</b>									
pH	10.0	8.1	10.3	Not measured	8.5	9.8	Not measured	6.5-9.5	
Temperature (°C)	Not measured								
Color (Pt-Co unit)	-								Acceptable by the end-user
<b>Oxygen Parameters</b>									
Dissolved Oxygen (mg/L)	Not measured								-
Oxygen Saturation (%)	Not measured								-
<b>Nutrient Parameters</b>									
Ammonium, NH <sub>4</sub> <sup>+</sup> (mg/L)	Not Measured								0.5
Nitrite, NO <sub>2</sub> <sup>-</sup> (mg/L)	0	0	0	0	0	0	0	0.5	
Nitrate, NO <sub>3</sub> <sup>-</sup> (mg/L)	0.07	0.3	0.11	0	0.34	0	0.5	50	
Total Phosphorus, P (mg/L)	-	-	-	-	-	-	-	-	
<b>Chemical Parameters</b>									
Total Dissolved Matter (mg/L)	152	43.4	178.8	263.0	33.4	165.8	230.0		
Free Chlorine, Cl <sub>2</sub> (mg/L)	-	-	-	-	-	-	-	0.2-0.5	
Chlorine, Cl <sup>-</sup> (mg/L)	5.35	5.27	5.52	5.29	4.33	8.32	5.77	250	
Sulphate, SO <sub>4</sub> <sup>2-</sup> (mg/L)	2.76	1.91	6.12	4.86	2.11	4.03	4.14	250	
Sodium, Na <sup>+</sup> (mg/L)	68.4	6.99	70.18	14.10	5.67	71.10	4.80	200	
Mercury, Hg (µg/L)	<0.1	<0.1	<0.1	<0.1	<0.1	<0.1	<0.1	1	
Cadmium, Cd (µg/L)	<0.05	<0.05	<0.05	<0.05	<0.05	<0.05	<0.05	5	
Lead, Pb (µg/L)	1.3	0.3	0.5	≤0.1	1.6	0.4	0.1	10	
Copper, Cu (µg/L)	0.4	0.8	0.5	1.5	4.2	1.5	5.3	2	
Nickel, Ni (µg/L)	2.4	0.3	0.4	<0.2	1.0	0.3	<0.2	20	
Zinc, Zn (µg/L)	7.9	1.7	1.7	<0.5	5.2	10.4	32.1	N/A	
Arsenic, As (µg/L)	10.3	1.2	12.5	1.0	1.8	7.8	0.7	10	
Total chrome, Cr (µg/L)	5.9	1.9	6.8	8.5	3.7	6.4	7.1	50	
Cobalt, Co (µg/L)	<0.02	0.07	0.05	<0.02	0.38	0.07	0.03	N/A	
Cyanide, Cy (µg/L)	-	-	-	-	-	-	-	50	
Fluoride, F <sup>-</sup> (µg/L)	0.64	0.15	0.82	0.24	0.11	0.50	0.28	1.5	
Sulphur, S (µg/L)	3000	2000	7000	6000	3000	3000	4000	N/A	
Ferrous, Fe (µg/L)	39	283	32	<10	2430	266	<10	200	
Manganese, Mn (µg/L)	5.28	1.72	1.34	0.77	15.6	4.17	0.66	50	
Boron, B (µg/L)	202	7	237	80	9	89	10	1000	
Selenium, Se (µg/L)	<0.5	<0.5	0.6	<0.5	<0.5	<0.5	0.6	10	
Barium, Ba (µg/L)	2.34	18.21	3.24	33.2	33.8	1.68	38.94	N/A	
Aluminum, Al (µg/L)	71	547	127	2	4488	448	25	200	
Radioactivity (mSv/yr.)	Not Measured								-
Organic Parameters	Not Measured								-
Bacteriological Parameters	Not Measured								-

Table 7-5: Electrical conductivity, pH, temperature, flow rate and static level measurements

Sampling Identification	Electrical Conductivity, EC (µS/cm)	pH	Temperature, T (°C)	Flow Rate (L/s)
<b>Groundwater</b>				
<b>Groundwater Springs</b>				
KVS (HEM2)	74	7.0	10.5	2.5
1	260	8.0	9.0	-
2	330	7.4	7.2	-
4	58	6.5	8.2	-
6	61	6.7	4.7	-
7	58	6.3	7.2	2.6 LPM
29	85	7.7	8.3	-
30	338	7.5	11.2	0.4
37	330	7.5	8.6	0.18
40	100	7.1	7.2	0.3 LPM
41	592	7.0	12.9	0.25
44 (HEM 6)	56	6.6	6.6	2
<b>Groundwater Wells</b>				<b>Static Level (m)</b>
HSK1 (HEM1)	303	9.1	16.1	77
HEMA2 (HEM4)	348	9.2	16.5	-
13 (HEM 7)	322	6.8	16.2	0
31 (HEM8)	430	7.4	12	1.8
33	603	7.1	12.8	1.9
<b>Surface Water (Creeks)</b>				
KVSD	65	7.3	7.3	N/A
42	280	7.9	9.2	N/A
43	180	7.9	8.1	N/A
<b>Municipal Water</b>				
45 (HEM 5)	540	8	-	500 L/s

Table 7-6: Results of chemical analysis

Sampling Identification	Na (mg/L)	K (mg/L)	Ca (mg/L)	Mg (mg/L)	Si (mg/L)	Alkalinity (mmole/L)	Hardness (°F) - Calculated	Hardness (°F) - Measured
<b>Groundwater</b>								
KVS (HEM2)	7.00	2.06	7.43	1.87	10.9	22	2.6	2.4
44 (HEM6)	5.67	1.84	8.27	1.65	14.6	19	2.8	4.4
<b>Groundwater Wells</b>								
HSK1 (HEM1)	68.35	0.40	3.55	0.50	15.1	122	1.1	1.6
HEMA2 (HEM4)	70.18	14.11	3.52	0.46	15.4	134	1.1	1.6
13 (HEM7)	71.10	0.45	6.07	1.31	16.3	138	2.1	2.6
31 (HEM8)	4.80	1.34	93.55	1.67	6.8	190	24.1	21.0
<b>Surface Water</b>								
KVSD (HEM3)	4.56	2.03	8.21	2.66	8.4	21	3.2	2.8
42 (HEM9)	16.51	1.20	42.83	4.06	11.5	112	12.4	13.4
43 (HEM10)	19.61	1.75	18.19	3.33	13.2	60	5.9	6.4
<b>Municipal Water</b>								
45 (HEM5)	14.10	0.90	88.05	12.75	6.9	220	27.3	26.2

The following results can be drawn from the above results:

- Well 13 that provides drinking water to Kaman Village has high Arsenic concentration of 7.8 µg/L that is very close to allowable limit of 10 µg/L. Arsenic is one of the key parameters to monitor at this well. Same well sample also has high ferrous concentration of 266 µg/L (allowable limit is 200 µg/L) and high aluminum concentration of 448 µg/L (allowable limit is 200 µg/L). Well HEMA2 is just 50 m away from HEMA water well (HSK1) and 250 m away

from Kaman Village drinking water well (13). Due to their geological formation of fractured andesite aquifer that contains arsenic; all three wells have high arsenic concentration as shown in Table 7-4.

- The sample HSK1 from HEMA water well (HEM1), sample HEMA2 – drainage water from HEMA ventilation shaft (HEM4) and sample 13 – drinking water well of Kaman Village (HEM7) have high sodium (Na) concentration and sample 31 (HEM8) has high calcium (Ca) concentration. Sample 45 is taken from municipal potable water supply in Ulupinar and sample 31 is obtained from an individually owned (sink) well. Please refer to Table 7-3 above for sampling identification and source.
- Samples HSK1, HEMA2 and 13 have high alkalinities as shown in Table 7-6, as well as high electrical conductivity values. From hydrogeological and chemical point of view, all three samples are sourced by the same aquifer. On the other hand, Kavsak Creek aquifer has different characteristics such as short circulation span in the strata and having high turbidity. This finding is supported with the observation of highly turbid catchment basin for Kavsak Creek during heavy precipitation. It is also concluded that this source is easily affected by rainfall.
- Water samples HSK1, HEMA2 and 13 are found to be richer for As, B, Li, Ni and Pb. These minor elements indicate a volcanic source. This finding is anticipated given that water is sourced by a fractured andesite aquifer. By temperature, samples HSK1, HEMA2 and 13 have average temperature of 16 – 16.5 °C, whereas remaining samples listed in Table 7-5 has average temperature of 4.7 – 12.9 °C.
- Ulupinar sample water can be considered as hard and sourced from carstic aquifer. Another example of hard water sample is individual (sink) well 31. It is understood that this well is located at Upper Cretaceous aged marn-limestone strata and high hardness due to the carbonated stratum.
- A diagram suggested by Gibbs (1970) is used as in Figure 7-10 to differentiate samples of water-rock interference that affect the chemical properties of water. It is concluded from the Table 7-6 that the chemical properties of water samples at wells HSK1, HEMA2 and 13 is developed by long-term water-rock interference; whereas, chemical properties of all remaining water samples of studied wells, springs and creeks is developed with the effect of rainfall and the duration of water circulation in these sources is not sufficient to generate a water-rock interference.

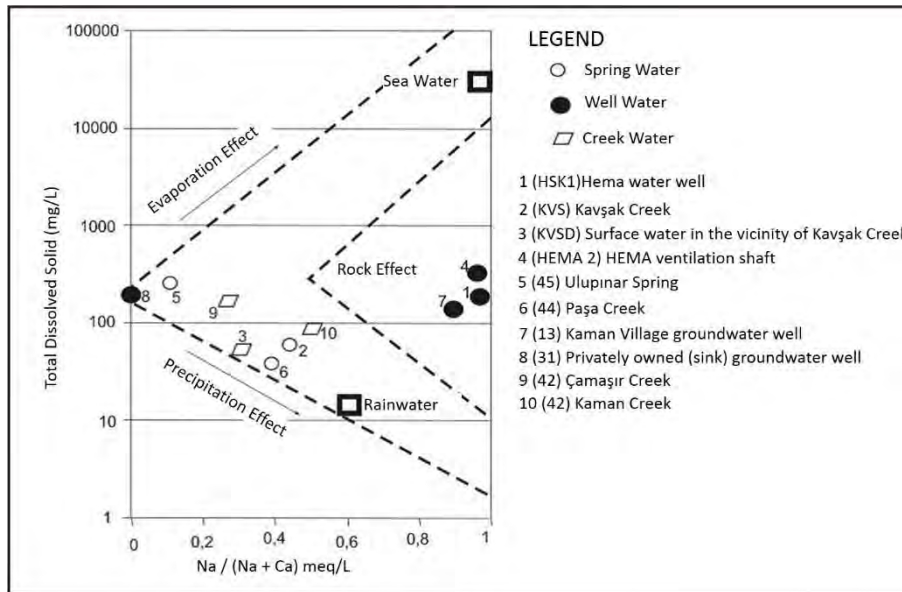

Figure 7-10: Na/ (Na+Ca) weight ratio versus logarithmic function of suspended matter (Gibbs, 1970)

### 7.2.3 Surface Water Resources

#### Streams and Surface Water Framework

Bartın Province has three main streams as Bartın, Arit and Kozcagiz Creeks as shown in Figure 7-11. Surface water resources in the region are briefly described as follows:

**Bartın Creek:** It is the most important water body in the region that crosses the Center District and reaches to Black Sea. Arit Creek flows in east-west direction into Bartın Creek. The area divided by Bartın Creek and its branches is steep and consists of deep valleys at the locations where the creek basin is expanded. The flow velocity of Bartın Creek is quite low as 720 m/hr and the annual average flow rate is 26 m<sup>3</sup>/s and as low as 5,88 m<sup>3</sup>/s in September according to Research and Development Study for Sustainable Environmental Investments (ENVIS, 2012).

The precipitation area of Bartın Creek is 1342 km<sup>2</sup>. Although Bartın Creek is one of the suitable water bodies for sea transportation, passenger and freight carriage cannot be executed due to decrease in the flow rate of the creek and reduced depth of the creek by alluvial material in recent years.

Bartın Creek is currently receiving all wastewater streams in the area and conveys them to Black Sea. Domestic wastewater generated in residential areas such as Ulus, Kurucasile, Kumluca, Kozcagiz, Arit including Bartın downtown are directly or indirectly discharged into Bartın Creek and end up in Black Sea. In addition, industrial district and Inkumu wild solid waste dumping site are situated adjacent to the banks of Bartın Creek. Based on the sampling analysis, Bartın Creek is classified as having Class II water quality. However, given the level of wastewater discharge, it is believed that the biological pollution is at much severe level. More sustainable approach toward pollution prevention should be prioritized for the creek.



Currently, no water supply scheme exists for Bartın Province from any surface water resource. The drinking water demand for the city is supplied from Kavsak Spring and Ulupinar fountain water. Sampling analysis result was explained in the following sub-section: *Surface Water Quality*.

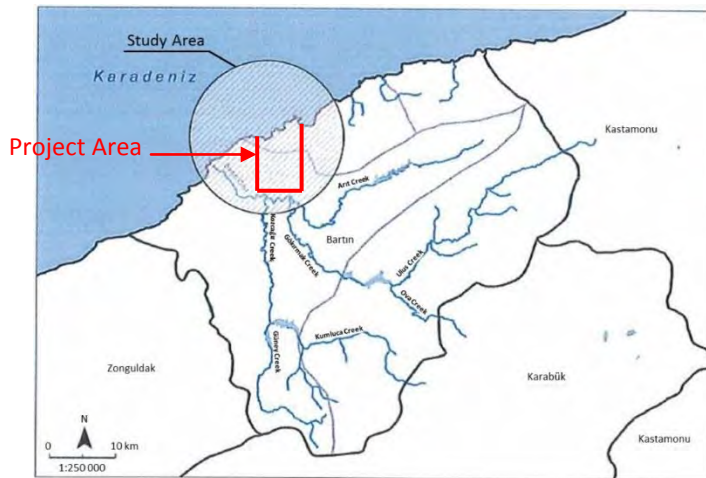

Figure 7-11: Surface water resources in Bartın Province

**Arıt Creek:** It is located in the east of Bartın Province. Although it crosses through the most productive agricultural fields of the province, it is not fully utilized for irrigation purposes.

**Kozcağız Creek:** It flows in southwest – northeastern direction as being one of the most important branches of Bartın Creek. Gunye Brook and Kocanaz Brook merges and forms Kozcağız Creek. Feeding area of the creek is 332 km<sup>2</sup>.

**Gokirmak Creek:** The creek which flows in south – north direction comprises of Goksu and Ulus (Eldes) Creeks originated in Kastamonu and passes Ulus District during which smaller streams flows into it. The creek first joins in Arıt Creek and then Bartın Creek in Bartın City Center. It has a feeding area of 1016 km<sup>2</sup> and has a flooding potential during heavy rain seasons.

Capak and Gomu Creeks are other surface water resources in close proximity to the Project area. These creeks are partially dried as indicated in Table 7-7.

Table 7-7: Bartın Province surface water potential

Water Source Type	Volume	Unit
Surface water (total provincial output)	1,248.38	hm <sup>3</sup> /year
Bartın Creek	-	hm <sup>3</sup> /year
Groundwater (total provincial, safe operational reserves)	29.20	hm <sup>3</sup> /year
Total provincial water potential	1,277.58	hm <sup>3</sup> /year
Surface area of natural lakes	-	-
Surface area of dam reservoirs	-	-
Surface area of reservoirs with embankment	-	-
Surface area of pond reservoirs	-	-
Surface area of streams		ha
Bartın and Arıt Creeks	150	ha
Kozcağız Creek	50	ha
Other	10	ha
Total surface area of streams	210	ha

Source: Bartın Provincial Environmental Status Report (2011)

Rainfall surface area and monthly meteorological data for main streams in Bartın Province is listed in Table 7-8 below.

Table 7-8: Bartın province hydrological measurements

Name	Watershed Area (km <sup>2</sup> )	Months											
		Jan	Feb	Mar	Apr	May	Jun	Jul	Aug	Sep	Oct	Nov	Dec
Gokirmak River (13-14 AGI Kirazlikopru)	1016.0	26.4	25.0	35.6	27.0	11.7	7.2	6.6	3.2	2.4	6.1	17.3	25.7
Arit River (13-49 AGI Darioiren)	137.0	5.22	6.2	7.1	6.0	2.4	3.3	1.7	1.0	1.7	2.8	5.8	6.6
Kozcagiz Creek (13-39 AGI Kozcagiz)	332.0	9.5	7.8	10.3	9.2	5.4	3.0	2.6	1.3	1.0	2.9	6.2	8.4

Source: Bartın Province Environmental Status Report, 2011

### Surface Water Quality

Samples from surface water sources are classified in accordance with the updated Turkish Regulation on Surface Water Quality Management (SWQM) published in Official Gazette date/no: 30.11.2012/28483. SWQM classifies surface water quality in four categories as: 1) Class I: High quality water, 2) Class II: Less polluted water, 3) Class III: Polluted water and 4) Class IV: Highly polluted water.

Water quality parameters highlighted in red in the table are not readily available in the updated regulation and to be included in the new regulation after January 1<sup>st</sup>, 2015 pending accumulating country database. Hence, surface water quality limits (highlighted in green) provided in previous SWQM regulation (i.e. Water Pollution Control Regulation dated 31.12.2004, issue number 25687) is utilized to classify water samples.

Surface water source for sample 43 is a creek in the vicinity of drinking water well of Kaman Village and groundwater well of HEMA. Water source for sample 42 is Camasir Creek and it is located on the east of above mentioned wells. Separate samples were obtained from those wells and results were discussed earlier in *Groundwater Quality*. Surface Water Quality data was obtained from the report by ENVIS Energy and Environmental Systems Research Development Ltd. (ENVIS), February, 2012.

Based on the results listed in Table 7-9 below, all three surface water sources are classified as Class III (Polluted Water) for pH. Sample 42 is classified as Class I; whereas samples KVSD and 43 are classified as Class II for ferrous (Fe). Similarly, sample 42 can be classified as Class III, samples KVSD and 43 are classified as Class IV for aluminum (Al) and all three samples are classified as Class IV for sulphur (S). It is apparent that three water resources are exposed to significant industrial discharge.

Table 7-9: Surface water samples and laboratory analysis results

Water Quality Parameters	Surface Water Quality Classes (Max values)						
	KVSD (HEM3)	42 (HEM9)	43 (HEM 10)	Class I	Class II	Class III	Class VI
<b>General Parameters</b>							
pH	8.6	8.7	8.9	6.5-8.5	6.5-8.5	6.0-9.0	Outside 6.0-9.0
Temperature (°C)	Not measured			≤25	≤25	≤30	≤30
<b>Oxygen Parameters</b>							
Dissolved Oxygen (mg/L)	-	-	-	>8	6-8	3-6	<3
Oxygen Saturation (%)	-	-	-	90	70-90	40-70	<40
<b>Nutrient Parameters</b>							
Ammonium-Nitrogen, NH <sub>4</sub> <sup>+</sup> -N (mg/L)	-	-	-	<0.2	0.2-1	1-2	>2
Nitrite-Nitrogen, NO <sub>2</sub> <sup>-</sup> -N (mg/L)	0	0	0	<0.002	0.002-0.01	0.01-0.5	>0.05
Nitrate-Nitrogen, NO <sub>3</sub> <sup>-</sup> -N (mg/L)	0.05	1.04	0.52	<5	5-10	10-20	>20
Total Phosphorus, P (mg/L)	-	-	-	<0.03	0.03-0.16	0.16-0.65	>0.65
<b>Inorganic Chemical Parameters</b>							
Chlorine, Cl <sup>-</sup> (mg/L)	5.29	8.83	9.44	25	200	400	>400
Sulphate, SO <sub>4</sub> <sup>2-</sup> (mg/L)	2.54	4.16	7.19	200	200	400	>400
Sodium, Na <sup>+</sup> (mg/L)	4.56	16.51	19.60	125	125	250	>250
<b>Metals</b>							
Mercury, Hg (µg/L)	<0.1	<0.1	<0.1	<0.1	0.1-0.5	0.5-2	>2
Cadmium, Cd (µg/L)	<0.05	<0.05	<0.05	<2	2-5	5-7	>7
Lead, Pb (µg/L)	0.9	0.2	0.6	≤10	10-20	20-50	>50
Copper, Cu (µg/L)	2.2	2.0	2.4	≤20	20-50	50-200	>200
Nickel, Ni (µg/L)	1.1	<0.2	4	≤20	20-50	50-200	>200
Zinc, Zn (µg/L)	4.6	1.0	2.1	≤200	200-500	500-2000	>2000
Arsenic, As (µg/L)	0.6	1.9	1.5	20	50	100	>100
Aluminum, Al (mg/L)	1.32	0.39	1.36	0.3	0.3	1	>1
Sulphur, S (µg/L)	3000	4000	7000	2	2	10	>10
Ferrous, Fe (µg/L)	841	206	801	300	1000	5000	>5000
Total chrome, Cr (µg/L)	2.0	6.3	4.4	20	50	200	>200
Cobalt, Co (µg/L)	0.22	0.09	0.25	10	20	200	>200
Cyanide, Cy (µg/L)	-	-	-	10	50	100	>100
Fluoride, F <sup>-</sup> (µg/L)	172	251	217	1000	1500	2000	>2000
Manganese, Mn (µg/L)	8.92	2.17	9.14	100	500	3000	>3000
Boron, B (µg/L)	6	34	22	1000	1000	1000	>1000
Selenium, Se (µg/L)	<0.5	<0.5	1.1	10	10	20	>20
Barium, Ba (µg/L)	27.81	17.68	13.68	1000	2000	2000	>2000

## 7.3 Impacts

### 7.3.1 Impacts on Groundwater Resources

#### Groundwater Availability

Groundwater usage permit for potable and utility water is requested by Hattat Enerji ve Maden Ticaret A.S. within the land parcel no.876 in Bartın Province, Amasra District, Kazpinari Village, Saptas Region from Ministry of Forestry and Water Affairs, 23<sup>rd</sup> Regional Directorate of State Hydraulic Works with an official application dated 13.09.2013 and the conditional permit is granted with an official letter dated 24.10.2011. It is also stated in the letter that, if “Kavsak Creek, Selen Spring and Kaman Village Watershed Mandatory and Short Distance Protection Zone” is expanded upon the court decision and the water well remains within this area, the groundwater usage permit will be cancelled according to the same official letter dated.

At each shaft bottom station in the Project, there will be 600 m<sup>3</sup> capacity water sumps for storing the drained groundwater. Water pumps will be used for draining the water from collection sumps in production areas and from the main water sumps at shaft bottoms.

Although the Research and Development Study for Sustainable Environmental Investments states that the groundwater potential in Bartın Province that can be safely withdrawn is determined as 6.0 Mm<sup>3</sup>/year, groundwater availability is still a concern for the community. Continuous water drainage will be required during coal extraction and processing. The depths of sump pumps are identified as -410 and -510 m. Total groundwater pumping capacity at the mine will be 540 m<sup>3</sup>/hr. Mining activities will affect the groundwater table of the whole the Project areas which (50 km<sup>2</sup>) encloses levels lower than -400 m in Field-A (14.4 km<sup>2</sup>) and the entire Field-B (35.6 km<sup>2</sup>). Hence reduction of groundwater availability is a concern at the local level and for communities in the vicinity of mining sites particularly in regions of high agricultural potential. Mining activities should therefore include adequate monitoring and management of water use, in addition to treatment of effluent streams including storm-water runoff from the mine property.

Groundwater can also be affected by mine subsidence in various ways including lowering of groundwater levels, changes in flow rates, and impacts to water quality. Lowering of groundwater levels may decrease the groundwater supply and result in the decrease or loss of well water, and decreased surface transmission to springs, seeps and other surface water sources (streams, lakes and ponds). Changes to flow include increases brought on by faster movement through fractured strata, accumulation of water, and reduced evapotranspiration. Decreases in flow may be brought about by water diversion caused by mining and mine subsidence. Alteration of water quality may be caused by changes in the chemical reactions and reaction rates with the minerals or surrounding strata (SME, 1986).

Therefore, impacts to groundwater resources are assessed to be minor to major depending on the drawdown cone of depression and depletion of groundwater resources.

#### *Groundwater Quality*

The following potential impacts were identified for construction and operation phases of the Project components:

- If the waste originated from the coal washing plant contains sulphides, the spoil dump could lead recharging of groundwater with sulphate-rich materials and therefore altering the groundwater quality beneath the sources. The risk for the contamination of groundwater would continue for the duration of coal processing, overburden dumping and coal transport/storage until the site is rehabilitated post-closure.
- Negative impacts may occur during the construction and also during the operation stage as a result of accidental spills from the use of hazardous materials (oils and lubricants) and storage areas, coal storage and windblown dust for all Project components if not handled appropriately.

In summary, impacts of the Project components on groundwater quality may change between minor to major depending on the mitigation measures taken.

### 7.3.2 Impacts on Surface Water Resources

#### *Surface Water Availability*

In an opinion letter by Ministry of Forestry and Water Affairs, 23<sup>rd</sup> Regional Directorate of State Hydraulic Works dated 16<sup>th</sup> February 2012, it is stated that the provided Project area is outside of the water collection basins of lakes and dams to be used as a drinking water source; only small seasonally active creeks are present. Neither a historical record of flow rate of the streams including the change of flow rate/the water quality for different seasons; nor a record for water appropriation within the Project area is present. Moreover, there is no observation station present and therefore water quality observations are not performed.

According to conducted studies in the region, there is no drinking water resource which supplies fresh water to Bartın Province from any of the surface water resources in the Project area. According to Bartın Provincial Status Report dated 2006, Kirazlikopru Dam and HEP constructed on Gokirmak in 2006 is aimed towards energy production, irrigation and flood protection as well as providing drinking, utility water and water for industrial use. Subject dam is outside of the Project impact area. Planned Kozcagiz Dam on Kozcagiz Creek is going to serve for flood protection and irrigation and Arit HEP on Arit Creek is going to be operated for irrigation and energy production.

During the construction of the mine, port and the coal washing plants, domestic water demand will be supplied from the existing well (HSK1) whereas bottled water is being used for drinking purposes. Once the coal extraction initiates, number of personnel working in the Project will be much higher with the addition of the port and coal washing plants staff. Moreover, the water requirement of the mining activities will significantly increase including the water needed in coal washing plants. Amount of maximum water demand of the Project was estimated as 1500 m<sup>3</sup>/day and HEMA stated that, to provide that amount of water, sea water will be treated using reverse osmosis process. Details of water use and sea water treatment will be discussed in *Chapter 8: Material Resource and Waste Management* in detail.

Given these circumstances, impact significance of the Project on surface water availability will be minor.

#### *Surface Water Quality*

The following potential impacts were identified for construction and operation phases of the Project components:

- Surface water runoff from Shafts 1, 2 and 3 and Spoil Dumpsites may cause contamination to downstream surface waters. The contamination of surface waters will continue for the life of the Project. Two seasonal creeks, Gomu and Capak, pass near Shaft-1 and Buyukdere Creek pass near Shaft 2. The risk for the contamination of these surface water resources would continue for the duration of mining, overburden dumping and coal transport/storage. In order to prevent the contamination of Buyukdere Creek, a concrete culvert was constructed for the creek to flow through waste rock dumpsite of Shaft-2 by the permit of 23<sup>rd</sup> Regional Directorate of State Hydraulic Works with the official letter dated 02.03.2009.

- If the waste rocks being originated during the construction of the mine galleries contain sulphides, it is likely that surface water quality will be adversely affected by the generation of sulphates, as well as increased turbidity from surface runoff near shafts, waste rock dumpsites and also the spoil dumpsites.
- Domestic wastewater will be generated during both construction and operation activities. Effluent discharges will be made to the Gomu Creek (Shaft-1) and Buyukdere Creek (Shaft-2). If left untreated, surface waters will adversely affect the surface water quality.
- Gomu and Capak seasonal creeks merge near the port area and flow into Black Sea. Possible impacts are expected to occur during the construction stage, and may continue during the operation phase. Operational activities such as accidental spills from the use of hazardous materials (fuel oils and lubricants) from the refueling and storage areas as well as runoff from quay, coal storage and windblown dust may affect these merged creeks and the sea which are highly sensitive.
- Waste rocks generated during the underground construction activities are currently placed near Shafts 1 and 2. The dumped waste rocks may adversely affect the downstream quality of Gomu, Capak and Buyukdere Creeks.
- Coal washing plants will be operated as a closed-circuit system in which the leakages and waste process waters will be fed back to the system. Therefore, a negative impact on surface waters is unlikely. The effects on surface water quality are confined within the footprint of the washing plants and potential downstream impacts are not likely to happen.
- Overland closed conveyor belt remains localized between Shaft-1 and HEMA Port. Conveyor corridor will be of 2 m width and the distance between the Shaft 1 and bulk cargo quay is approximately 1,000 m. The entire footprint of the route will be utilized. The conveyor will pass close to seasonal Gomu Creek. Given the presence of sulphides in coal material, the interaction of surface/rain water with coal on conveyors may pose a contamination risk along the conveyor corridor and the contamination would possibly reach to the sea in case of an accident or spill with storm water interaction.
- Surface resources support aquatic ecology in riverine and the sea. Therefore, surface water resources are highly sensitive.

In addition, a number of construction activities may have adverse effects on the existing surface water resources. These activities include:

- Spills/accidents of hazardous chemicals during development, construction and operation phases at all Project components;
- Leakage from fuelling stations, maintenance activities and storage of hazardous materials and wastes;
- Infiltration of storm water through stockpiles and waste rock dumps;
- Leaching of hazardous chemicals from storage areas and rock dumps.
- Soil and concrete movement due to excavations and the presence of stockpiles of exposed soil (including contaminated soils identified during the soil quality investigation) and concrete which may lead to suspended sediment in runoff waters from the work sites.

In summary, impacts on surface water quality are assessed to be of major significance if mitigation measures are not undertaken.

## 7.4 Mitigation Measures

Specific mitigation measures for the management of water resources during the Project activities, according to the national regulations and IFC Standards include the following:

- The waste rock dumpsite around Shaft-2 is very close to the borders of the defined Drinking and Utility Water Short Distance Protection Zone. Since any kind of waste dumping and storage is prohibited in the zone, excavated waste rock resulting from underground construction activities will not be placed in that direction.
- The surface water (a branch of Buyukdere Creek) flowing through the concrete culvert near Shaft-2 will be monitored and periodically cleared off any blockages according to official letter of 23<sup>rd</sup> Regional Directorate of State Hydraulic Works dated 02.03.2009.
- According to the official letter of 23<sup>rd</sup> Regional Directorate of State Hydraulic Works, dated 20.02.2013;
  - Stream beds of Gomu and Capak will be protected,
  - Mouth of the stream will not be constricted,
  - Creeks will be cleared off any residues to bring the stream beds to their original conditions,
  - There will be no interference to the stream beds,
  - Stream beds will be cleaned before and after the flood season and also at most in three-month periods within the knowledge and under control of the Directorate.

Specific additional mitigation measures to avoid and/or mitigate the potential impacts to surface water and groundwater will need to include the following:

- Dust and sweepings will be appropriately managed and the ground will be paved in order to minimise potential runoff and interaction of water with coal in the Project area.
- Good construction site practices will be adopted to minimize risks of water pollution.
- Storm water runoff from the mine property will be monitored adequately in addition to treatment of effluent streams and will be transferred to the wastewater treatment unit to meet the discharge criteria specified in the relevant national regulations, if deemed necessary.
- The high rate of occurrence of acid drainage and associated metals contamination associated with mining operations is well documented and is recognized as a major adverse consequence of many hard-rock metals mining operations. Therefore, the acid generation potential of discard, product, spoil and waste rock samples will be determined using acid base accounting (ABA) to assess whether the coal from the area is likely to be acid generating or not. In addition,
  - verification of metal leaching and neutralising potential of the overburden material (sandstone, clay, dolerite, and potentially small quantities of coal),
  - conducting kinetic field tests on waste rock and spoil samples to determine the duration of oxidation (and hence potential surface and groundwater contamination), and

- reviewing the waste management strategy according to the results of the tests above will be undertaken.
- No fuelling of vehicles or equipment will take place within the excavated areas; no hazardous materials will be stored in excavated areas. Fuelling shall only be carried out in designated areas away from surface drainage pathways.
- Suitably sized impervious bunds or other containment will be installed where hazardous materials are handled (such as fuels/chemicals/hazardous materials storage and loading areas, concrete mixing) to prevent hazardous materials entering the site runoff.
- A Hazardous Material Management Procedure will be included in Environmental Management Plan to ensure proper handling of hazardous materials during construction and operation of the port, coal washing and mining facilities.
- Groundwater levels in the vicinity of the mine will be monitored on a regular basis throughout construction, operation and post-closure phases. Mine dewatering volumes/rates should also be monitored throughout the operational phase of the Project. The monitoring data should be stored in an appropriate data management tool/database.
- Springs and other wells used by villagers or any other public institutions will be monitored in terms of availability and quality throughout the operational phase of the Project. In case of any contamination/decrease in the availability of water sources, necessary mitigations will be undertaken.
- It will be prudent to perform seasonal or annual measurements and chemical analysis of drinking quality of water instead of a single or short-term measurement since arsenic concentration for well 13 is 6.5 times higher than that of Kavsak Creek water sample (KVS) and 7.8 times higher than that of municipal drinking water sample (45).

## 7.5 Residual Impacts

Assuming that mitigation measures mentioned above and those mentioned in relevant chapters (i.e. *Chapter 6: Geology, Soils and Contaminated Land* and *Chapter 8: Material Resources and Waste Management*) are implemented and good site practices are adopted, the residual impacts on the surface water and groundwater is estimated to be minor.



## 8.0 MATERIAL RESOURCES AND WASTE MANAGEMENT

### 8.1 Scope

The potential impacts from the use of material resources and generated wastes during construction and operation of the Project are discussed in this chapter. A description of the material resources that will be required for the construction and operation of the Project is provided. The types of waste that will be generated by the Project during construction and operation phases have been identified and potential impacts to environment, and community related to inadequate solid and liquid waste management during construction and operation phases are examined in detail.

### 8.2 Material Resources

#### *Construction Materials*

During the construction of the mine, there will be a variety of material items which will be used. Main resources of materials are shown in Table 8-1 as provided by HEMA. These will be provided by the HEMA; however, at this stage their sources are not known. The construction materials required for the mine are transported from suppliers to the site via roads. Given the size of the construction sector in Bartın, it is not expected that all materials can be supplied from the existing market

Table 8-1. Main Material Items for Mining Activities

	Material	Approximate Amounts	Unit
<b>Spraying Concrete Fortification Materials</b>	Gravel	25,700	tons
	Aggregate	3,400	tons
	Cement	15,450	tons
	Accelerator	640	tons
<b>Steel Fortification Materials</b>	Rock bolts (total)	80,000	pieces
	Sheer connector set	100,000	sets
	Steel mesh	1,440	tons
	Iron bonding	2,500	tons
<b>Conveyor Railways</b>	Rail	550	tons
	Travers	750	tons
<b>Maintenance and Repair Materials</b>	Oils	10	tons
	Oil filters	300	pieces
	Manufacturing Materials (steel plates, brass/casrermid materials, etc.)	70	tons
<b>Electrical Facilities and Wiring</b>	Electric Cables of various types	85,000	meters
	Substation	19	pieces
	Circuit Breaker	10	unit
<b>Explosive Materials</b>	Dynamite	275	tons
	Electrical Delayed Action Fuse	467,000	pieces
	Water Filter Cartridges	81,000	pieces

Each of the three shafts, which have been installed based on the targeted production, has an 8 m diameter. Shafts 1, 2 and 3 have depths of 700 m, 730 m and 580 m respectively. Minimum concrete thicknesses in shafts are 50 cm. Concrete volumes for each shaft are listed in Table 8-2 below.

Table 8-2. Total concrete volume for shafts constructions

	Shaft-1	Shaft-2	Shaft-3
Total concrete volume (m <sup>3</sup> )	9,342	9,742	7,740

Besides the delivery of materials, various types of vehicles and machinery are currently used and will continue to be used during the construction and operation phase. These are identified in *Chapter 2: Project Description* and will all be sourced locally as far as possible from existing suppliers except for the industry-specific equipment.

Wastes of the coal washing plants will be deposited in the two engineered spoil dump storage facilities, which are called Spoil Dumpsites henceforward. One of these sites will be near the entrance of the shallow coals, where the first coal washing plant will be located with the surface area of 7,186 m<sup>2</sup>; whereas the other site will be constructed near Shaft-1 with the surface area of 88,465 m<sup>2</sup> for the wastes of the main project coals. In order to construct these two separate spoil dumpsites; clay, geomembrane, gravel will be needed to ensure ground protection. The amounts of resource materials are not known yet since the project design for the dumpsites will be undertaken at a later stage.

For the port construction, a 490-meters long breakwater in the east-west direction for the protection of the quay structures has been designed with reclamation and excavation areas having surface areas of 72,000 m<sup>2</sup> and 22,000 m<sup>2</sup>, respectively. The estimated reclamation volume is approximately 1.5 million m<sup>3</sup>. The filling material will be obtained from the stone quarry located 250 meters away from the project site of the port. It has a surface area of 100,000 m<sup>2</sup> and an ore thickness of 40 m; therefore the total reserve of the stone quarry is estimated as 100,000 m<sup>2</sup> x 40 m x 2.7 tons = 10,800,000 tons. The quarry has an II-a operating license, numbered 200906279, in the name of Hema Endüstri A.Ş.

It is anticipated that approximately 40,000 tons of aggregate, 90,000 m<sup>3</sup> of concrete, 130,000 tons of gravel, 32,000 tons of cement, 6,000 tons of iron, 500 tons of ammonium nitrate (ANFO) 150 tons of gelatine, and 1,000,000 m<sup>3</sup> of blockstone will be needed for the port project. Construction of the quay will involve installation of tubular steel piles into the seabed after which the quay structure will be constructed on top. Piles will be driven using floating equipment and will subsequently be filled with concrete. Beneath the platform and the dolphins, approximately 4800 tons of steel tubes each having a diameter of 1219 mm will be constructed with a total length of 9000 meters and a thickness of 18 mm. The top 4 meters of each tube will be painted with 600 micron epoxy paint and 400 micron epoxy paint will be used for the rest. Moreover, a catwalk will be installed between the quay and the dolphins with 39 tons of steel. The catwalk will be galvanized with hot-dip galvanized coating in order to ensure protection against corrosion. Concrete tetrapods with a total mass of 30 tons will be used on the outer part of the constructed breakwater to absorb the wave energy.

During the Project, the company will be responsible for identifying sources for all materials and equipment and will be required to consider environmental impacts when selecting materials to be used for the Project. This will include using less harmful materials where possible, considering the carbon footprint of alternative materials and considering the impacts of extraction, processing and transport. In particular, the company will be required to:

- source materials as close as possible to the Project site in order to minimize the impact of transport;
- use recycled materials and materials certified as being from “green” or sources with lower carbon content where possible;
- source the aggregates and materials from quarries, borrow pits, crushing plants and asphalt plants operating with valid environmental and other permits and licenses; and from sites that are managed in full compliance with all applicable environmental standards and specifications.

#### Water Demand

Drinking and potable water will be used during the construction and operation phases of the Project. A 300 lt/day/capita of water usage was stated by HEMA, as a daily water requirement of the construction workers. A total of 790 employees are currently working in mine construction. Therefore, the domestic water demand of the mine workers is estimated to be 237 m<sup>3</sup>/day. During the construction of the coal washing plants and the reclamation area and the quay, a total of 120 persons is estimated to be working whereas, during the operation phase, 86 and 65 persons are estimated to be working for the coal washing plants and the port, respectively. Since the mine will be in operation shortly, water demand during the constructions of the coal washing plants and the port is included in the operation phase of the Project. Consequently, during the operation, maximum number of personnel is projected to be 2,400 and estimated domestic water demand is 720 m<sup>3</sup>/day.

Table 8-3. Total water consumption of the Project

	Water required for domestic usage		Water required for mining activities		Water required for coal washing plants		Total	
	Construction Phase (CP)	Operation Phase (OP)	CP	OP	CP	OP	CP	OP
Water extracted from HKS1 (m <sup>3</sup> /day)	237	-	207	-	-	-	444	-
Water drained from Shafts (m <sup>3</sup> /day)	-	-	50	400	-	-	50	400
Water obtained from sea water treatment unit (m <sup>3</sup> /day)	-	720	-	590	-	240	-	1550

Currently, the process and domestic water is being supplied from the 300 meters deep licensed HSK-1 groundwater well in Kazpinari, whereas drinking water is supplied as bottled water. On the other hand, with the expected increase, water demand during the operation phase will be supplied from the sea water. Therefore, HEMA is planning to construct a sea water treatment unit with the capacity of 1,500 m<sup>3</sup>/day. In case of an increase in the on-site staff, drinking water package treatment plants will be installed near Shaft-1 and Shaft-2 in order to improve the quality of the groundwater to meet drinking water standards.

In addition, during construction and operation of the mine, water will be drained from the shafts in order to ensure safe working conditions and to enable the extraction and hauling of coal. Daily, 50 m<sup>3</sup> and 400 m<sup>3</sup> of groundwater will be drained during the construction and operation phases, respectively. This volume will be used in mining activities such as; construction and drilling

equipment, concrete spraying and coal washing process, which all require high volumes of water. Water consumption of the mine is given in Table 8-3.

### Sea Water

1500 m<sup>3</sup> of sea water will be treated daily in order to meet the domestic usage and required amount for the mining activities. The treatment scheme of the sea water treatment unit is given in Table 8-4. After the treatment, pH of the water will be around 6.5 -7.0 whereas the total suspended solids (TSS) and total dissolved solids (TDS) parameters will decrease to less than 0.1 mg/L and 200 mg/L, respectively. The system will also reduce the conductivity of the sea water to less than 400 µS/cm with turbidity lower than 0.1 NTU.

Table 8-4. Steps of the sea water treatment and aims of the processes

Treatment Processes	Aim of the process
- Chlorine dosing	Prevent the microbial contamination of the system and provide oxidation
- Coagulant dosing (PACl)	Enhance filtration efficiency
- Full automated Strainer Filter	Remove the coarse particulate matter in the sample
- Sand Filter	Remove suspended solids (SS) and particulate matter in the sample
- Sodium metabisulphate (SMBS) Dosing	Remove the residual chlorine in order to protect the RO membranes
- Anti-scalant Dosing	Prevent the scaling on RO membranes
- Reverse Osmosis (RO)	Remove chemical compounds in the water such as total dissolved solids, silica, conductivity and hardness generating matters, etc.
- NaOH Dosing	Balance pH
RO chemical and back washing	Maintenance of RO membranes

### Electricity

The electricity will be provided by the 154 kV Transmission line and the 31.5 kV Distribution Line which will be initially built by HEMA and, after expropriation, operated by Turkey Electricity Transmission Inc. Com. (TEIAS). Additionally, with the methane drainage system which is to be installed in order to recover the methane gas during the underground activities, electricity will be produced by generators having roughly a capacity of 3 to 5 MW. Underground electricity demand will be provided through this system and the excess power –if there would be any- will be used for heating purposes.

### Food / Meal

Meal service will be provided in the cafeterias of HEMA, operated by the contractor during the construction and operation phases for all Project components. There are three dining halls near Shaft-1, two near Shaft-2, and two located near Shaft-3.

## 8.3 Waste Management

Waste management operations such as collection, storage, transport and disposal during the construction and operation phases of the Project are required to be in full compliance with the

Turkish regulatory framework. The Turkish regulations that govern the wastes that will be generated during construction and operation of the Project are as follows:

- Regulation on General Principles of Waste Management (Official Gazette (OG) Date/ Number: 05.07.2008/26927)
- Law of Aquaculture Numbered 1380 (OG Date/Number:04.04.1971/13799)
- Regulation on Aquaculture (OG Date/Number:10.03.1995/22223)
- Water Pollution Control Regulation (OG Date/Number: 31.12.2004/25687)
- Regulation on Environmental Permits and Licenses (OG Date/Number: 29.04.2009/27214)
- Regulation on Sanitary Landfills (OG Date/Number: 26.03.2010/27533)
- Urban Wastewater Treatment Regulation (OG Date/Number:08.01.2006/26047)
- Regulation on Control of Excavated Soil, Construction and Demolition Wastes (OG Date/ Number: 18.03.2004/25406)
- Hazardous Waste Control Regulation (OG Date/Number: 14.03.2005/25755)
- Solid Waste Control Regulation (OG Date/Number: 14.03.1991/20814)
- Packaging Waste Control Regulation (OG Date/Number: 24.07.2007/26562)
- Waste Oil Control Regulation (OG Date/Number: 30.07.2008/26952)
- Regulation on Control of Waste Batteries and Accumulators (OG Date/Number: 31.08.2004/25569)
- Medical Waste Control Regulation (OG Date/Number: 22.07.2005/25883)
- Regulation on Control of Waste Vegetable Oils (OG Date/Number: 19.04.2005/25791)
- Regulation on Reception of Ship-Generated Waste and Waste Control (OG Date/Number: 26.12.2004/25682)
- Communiqué on Road Transportation of Waste (OG Date/Number: 18.01.2013/28532)
- Regulation on Control of Waste Electrical and Electronic Equipment (OG Date/Number: 22.05.2012/28300)
- Communiqué on Recycling of Certain Non-hazardous Waste (OG Date/Number: 17.06.2011/27967)

In addition to the Turkish Environmental Legislation, waste management practices for the Project will also need to abide with the following IFC Guidelines:

- IFC General Environmental, Health and Safety Guidelines
- IFC Environmental, Health and Safety Guidelines for Mining
- IFC Environmental, Health and Safety Guidelines for Ports, Harbors, and Terminals
- IFC Environmental, Health and Safety Guidelines for Waste Management Facilities

The Turkish regulatory framework requirements and the conditions set in the IFC guidance documents provide inherent mitigation measures against the potential impacts resulting from waste generation. These conditions were reviewed and are discussed in Section 8.7.

#### **8.4 Existing Waste Management Conditions in Bartın**

The existing waste generation and management in Bartın, the on-going disposal practices and a review of the waste disposal facilities in Bartın Province are presented in this section. The information was gathered to review whether the waste that will be generated in the construction and operation phase of the Project can be managed in line with the Turkish regulatory requirements.

Information on baseline conditions has been identified using the following sources:

- Bartın Province Environmental Status Report - 2013,
- Official Website of Ministry of Environment and Urban Planning.

#### 8.4.1 Overview of Waste Generation

Waste generation data given in the Bartın Province Environmental Status Report of year 2013 are presented in Table 8-5.

Table 8-5. Waste Generation in Bartın Province and Amasra District

Waste Category	Waste Amount	
	Bartın Province	Amasra District
Domestic Waste (kg/day)	134,050	32,167
Medical Waste (kg/day)	255	2.64
Excavation Waste (kg/day)	6,350	-
Ash (kg/year)	2,633,500	-
Others (kg/day)	9,000	-

*Bartın Province Environmental Status Report-2011*

#### 8.4.2 Waste Disposal and Treatment Facilities

There are no proper waste management practices undertaken in Bartın Province due to the lack of waste management facilities.

##### *Industrial Wastewater Treatment Plant*

An industrial wastewater treatment plant with the capacity of 1700 m<sup>3</sup>/day is currently in the construction phase in the organized industrial zone of Bartın.

##### *Wastewater Treatment*

There are 4 districts in the province and sewage systems of these settlements are substantially completed; however, none of the municipalities have treatment plants. Therefore, domestic wastewater of the urban areas is directly discharged to streams or creeks; whereas the great majority of the rural population discharges the wastewater to septic tanks. Nevertheless, all of the Bartın municipalities have wastewater projects to be implemented in the coming years.

##### *Solid Waste Treatment*

There is no sanitary landfill site in Bartın and so the generated solid waste is currently being disposed in an uncontrolled dumpsite in Gurgenpinar and Bogaz Inkumu regions. However, a solid waste disposal facility is projected within Kaman Village on a surface area of 98,030 m<sup>2</sup> and EIA process of the facility was completed.

##### *Medical Waste Treatment*

Other than that, a total of 180,606 kg/day medical waste is generated in Bartın. All medical waste is disposed at the İlke-Rohan Medical Waste Sterilization Plant in Zonguldak according to the agreement between the plant and the Union of Bartın Municipalities.

There are only two licensed waste management facilities in Bartın Province according to the Ministry of Environment and Urban Planning database. Facility details are given in Table 8-6.

Table 8-6. Licensed Waste Management (Recycling / Disposal) Facilities located in Bartın Province

Facility Name	Facility Address	License Type	License Due Date
Safran Geri Dönüşüm/ Yusuf Muhit-Bartın Şubesi	Gürgenpınar Köyü Kumtarla Mevkii Merkez/BARTIN tel:3707127673 fax:3707127673	Packaging Waste Recovery	12.02.2019
Bartın Limanı ve Atık Kabul Tesisi	Bogaz Mevkii Bartın Limanı Tel:3782385851 Fax:3782385851	Waste Acceptance Facility (Wastes from Ships)	31.10.2018

The closest licensed waste management facilities for proper waste management are identified in Table 8-7 below.